



Butterfly\Knife Gate\Resilient Gate\Gate\Globe\Check
\Ball\Plug\Strainer

Water, Waste Water, Sewage

Product Application Manual

DBV Valve Co., Ltd. was established in 2001 and is headquartered in Oubei, Yongjia, Zhejiang, the hometown of pumps and valves in China. It is a modern enterprise integrating the manufacture, sales and service of various intelligent control valves (pneumatic, electric and hydraulic control). We have a factory building area of more than 20,000 square meters, more than 200 sets of machine equipment and more than 300 employees.

The company has been awarded the titles of National High-Tech Enterprise, A-class Tax Credit Enterprise of Zhejiang Province, and Star Enterprise of Yongjia County, etc. It has also been certified by American Petroleum Institute (API), Customs Union TR Declaration (EAC), German Technical Supervision Association (TUV) and Det Norske Veritas (DNV).

The company mainly produces high pressure severe service products and metal to metal seat butterfly valves, metal to metal seat ball valves, low temperature valves, etc., which are manufactured strictly according to ISO, ANSI, API, GB, HG and other standards. We have advanced physical and chemical testing centre, professional CNC machining and test pressure automatic production equipment and experienced technical production team. Product pressure from 150LB-2500LB, 0.6 MPA-42.0MPA, temperature resistance -196°C - 800°C.



Valve Production Workshop



Company Headquarters (Under Construction)



Frontline Staff

2001

Open

Year of Establishment

2016

International

International Trade Business

2018

New

Pump and Valve Base

2021

Certified

National Certification

2023

Now

Choose Us For Quality

Relying on our strict quality management system, our products are widely used in petroleum, petrochemical, natural gas, coal chemical, metallurgy, electric power and other industries, and exported to Europe, America, Asia Pacific, the Middle East and other countries and regions, the company has been approved by Oman National Oil Company, Iran South Oil Company, Thailand National Power Plant, Russia National Oil Service and other large international terminal customers.

In terms of research and manufacturing, the company has a number of senior R & D teams, advanced manufacturing equipment, perfect physical and chemical testing and inspection methods (spectrometer, helium mass spectrometer, high and low temperature comprehensive performance test equipment, etc.), scientific information management system (integrated PDM, ERP, CAD, CAPP), comprehensive resources to provide customers with sustainable product solutions and collaborative service support.

As a fluid control solutions provider, the company is committed to innovation and service enhancement and is constantly striving to become one of the world's most professional, comprehensive and reliable valve manufacturers.

Equipment & Professional Team

Equipment & Professional Team

20⁺

Years

Manufacturing Experience

200⁺

Units

Manufacturing Facilities

300⁺

People

Practitioners

3

Teams

R&d Team

20000⁺

Square Metres

Intelligent Factory Floor Space

More Than 20 Years Of Experience In R&d And Production Exported To More Than 30 Countries And Regions Worldwide.

200 + Sets Of Intelligent Manufacturing Equipment	20 + Years Of Experience In R&d And Production	Exported To 30 + Countries Worldwide
4000 + Square Metres Of Finished Goods Warehouse	Over 300 Valve Practitioners	3 Valve Production Bases
Annual Production Of Over 8000 Tons Of Valves	3 Senior Valve R&d Teams	Intelligent And Scientific Production
20,000 + Square Metres Of Factory Floor Space	Professional Multilingual Sales Staff

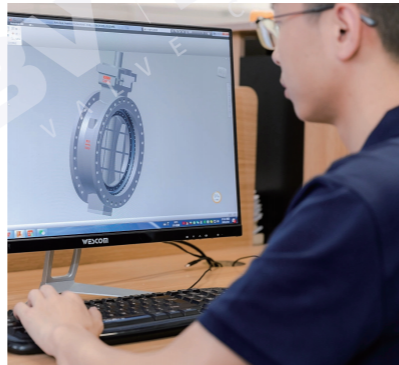

Customers & Partners

Customers & Partners



DBV Valve Co., Ltd. is a fluid control solution provider that has been developing and producing ball valves and butterfly valves in China for more than 20 years. Our sales and service network extends to dozens of overseas countries and regions, and our end products are used by companies such as Petronas, Anadarko, Petrobras, Lukoil.

The company has been approved as a qualified supplier by large international terminal customers such as Oman National Oil Company, Iran National South Oil Company, Thailand National Power Plant and Russia National Oil Company.



Honors & Qualifications

Honors And Qualifications

Qualification is the guarantee of an enterprise's products, and honour is the silent motivation of an enterprise.

In terms of product standards and quality, the company has obtained the "API6D, API609 Valve Production Design Standard Certification" issued by the American Petroleum Institute API, the "API6FA, API607 Valve Fire Test Certificate", the "SIL-3 Safety Equipment Integrity Level Certificate" issued by the German Technical Supervision Association TUV, the CE Certificate, the "ATEX Explosion Test Certificate" issued by the Norwegian Classification Society DNV and many other international certifications.

The company was awarded the title of national high-tech enterprise, the title of science and technology-based small and medium-sized enterprise in Zhejiang Province, the title of star enterprise in Yongjia County for three consecutive years, the excellent supplier of government procurement and many other honorary titles.

DBV valves are manufactured in accordance with the ISO 9001 quality management system and are subject to 48 production processes, comprehensive testing and inspection in accordance with international standards, thus guaranteeing the high quality of DBV valves.



DBV Certificates

API 6D	API 609	CE
ISO 9001	ISO 45001	ISO 14001
API 6FA/607	ISO 15848-1/API624	BS 6364
SIL-3 Ball Valve	SIL-3 Butterfly Valve	SIL-3 Control Valve
TR CU 032	TR CU 012	TR CU 010
MSK-64 Ball Valve	MSK-64 Butterfly Valve	ATEX

Multi-Field Application Solutions

Multi-Field Application Solutions

Since its inception, DBV Valve has always been deeply involved in the valve field, with scientific and cutting-edge R&D and production processes, providing reliable, safe and economical fluid control solutions to customers worldwide in a variety of industries. With years of customization of fluid control solutions, DBV Valve has developed and produced a series of valves for various industries worldwide, including but not limited to: fine chemical industry, coal chemical industry, marine industry, new energy field, oil refining and petrochemical industry, metallurgical and mining industry, pharmaceutical and pesticide industry, nuclear power industry

Industry-wide, Multi-type Fluid Control Solutions

Fine chemical industry	New Energy Sector	Pharmaceutical And Pesticide Industry
Coal chemical industry	Oil Refining And Petrochemical Industry	Nuclear Power Industry
Marine Marine Industry	Metallurgical And Mineral Industries	Technology And Environmental Industry



Butterfly Valve

DESIGN DETAILS

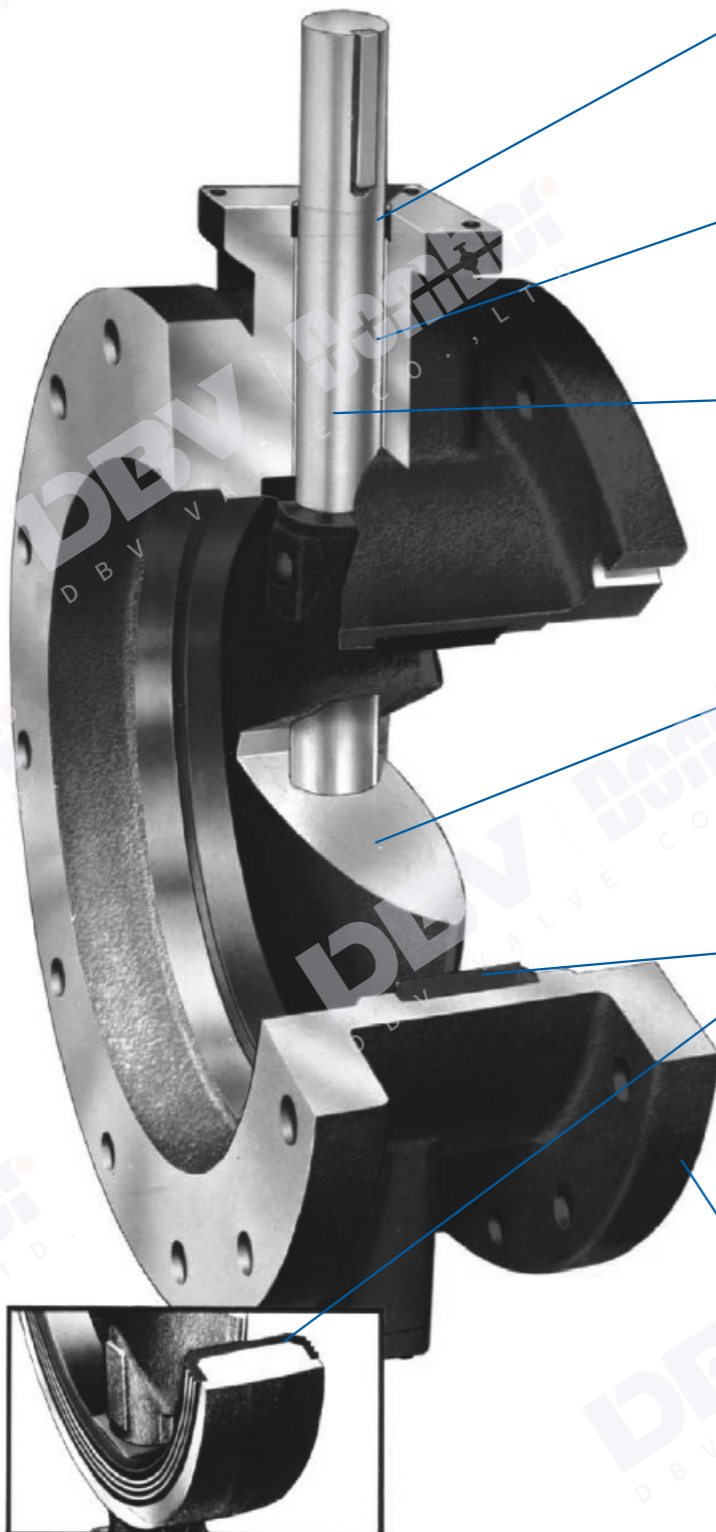

SELF ADJUSTING PERMANENT PACKING

Chevron type packing increases sealing force as line pressure increases. The self adjusting packing bears on turned, ground and polished stainless steel, minimizing wear and assuring long life. Packing is accessible for replacement without dismantling the valve per AWWA Standard C504.

LIFETIME BEARINGS

DBV's chemically inert nylon bearings are sized to meet or exceed AWWA specification pressure loads. They are self-lubricating, require no periodic maintenance and are designed to outlast the life of the pipeline.

CORROSION RESISTANT SHAFTS

The shafts in DBV's rubber seated butterfly valves, 3" through 20" , are constructed of centerless, ground ASTM A276 type 304 or type 316 stainless steel bar and thus are not susceptible to corrosion as are carbon steel or other similar materials. Shafts are one-piece, through-shaft construction, sized to meet or exceed the requirements of AWWA Standard C504 for Class 150B butterfly valves.

STREAMLINED DISCS

DBV's lens-shaped discs are designed to minimize pressure drop and turbulence. In the full open position, the disc creates no more friction loss than a 45° elbow. Discs are secured to shafts by stainless steel pins to transmit required torques and withstand stresses imposed under a variety of operating conditions.

BODY SEAT

Our standard seats are constructed of Buna N rubber and bonded to the valve body in DBV's manufacturing facility using a unique thermal process. This molding process ensures that the disc-to-seat interference will not cause excessive wear or abrasion under normal operating conditions. On the wafer type bodies, the rubber seat covers the entire inner surface plus the outside face of the valve body to provide a self-gasketing feature. DBV's seat-in-body design minimizes the effects of corrosive buildup on the inside of the valve because deposits are swept away by the hard sealing edge of the disc each time the valve is exercised.

HEAVY DUTY BODIES

Both Monoflange and Flanged bodies are heavy duty cast iron. Flanged Bodies are fully faced and drilled in accordance with ANSI B16.1, Class 125 standard for cast iron flanges. Monoflange bodies incorporate an overlapping seat which also forms a gasket for the flange face. The actuator mounting trunnion is machined and drilled for a 4-bolt connection.

SCOPE OF LINE: AWWAIN-PLANT RUBBER SEATED BUTTERFLY VALVES



FLANGED BUTTERFLY VALVE

- SIZES:** 3 through 20 inches
BODY STYLE: Flanged x flanged ends
OTHER BODY STYLE OPTIONS:
- Mechanical joint
 - Victaulic
 - Flanged & mechanical joint
 - Push-on
 - Push-on & flanged
- PRESSURE CLASS:**
- Class 150B per AWWA Standard C504

- WORKING PRESSURE:** 150 psig
FLANGES:
- Flat faced and drilled in accordance with ANSI B16.1, Class 125 standards.
- RUBBER SEAT:** Bonded seat-in-body
ACTUATION OPTIONS:
- Hand lever
 - Manual actuator with AWWA nut, Handwheel or chainwheel
 - Hydraulic or pneumatic cylinder
 - Positron electric actuator



MONOFLANGE WAFER BUTTERFLY VALVE

- SIZES:** 3 through 20 inches
BODY STYLE: Wafer-type
PRESSURE CLASS:
- Class 150B per AWWA Standard C504
- WORKING PRESSURE:** 150 psig
RUBBER SEAT:
- Bonded seat-in-body extends over inner surface to form self-gasketing feature

- ACTUATION OPTIONS:**
- Hand lever
 - Manual actuator with AWWA nut, Handwheel or chainwheel
 - Hydraulic or pneumatic cylinder
 - Positron electric actuator

FEATURES AND BENEFITS

FEATURE

Seat-in-body design
 Seat molded in recessed body cavity, protected by metal on 3 sides

Valve withstood proof-of-design testing of 100,000 cycles - AWWA only requires 10,000 cycle proof-of-design testing

Through-disc pinning

Symmetrical lens-shaped disc

Nonmetallic bearings

Chevron V-type packing

BENEFIT

Reduces seat failure due to corrosive buildup in the valve and pipeline. No hardware to loosen. No periodic maintenance required. Rubber protected from flow media to increase seat life.

Proven reliability over the life of the valve

Provides a tight disc-to-shaft pin connection, greatly reducing the possibility of loosening through vibration

Higher Cv : lower head loss results in energy savings for customer's system

Prevents galvanic corrosion and provides lower coefficient of friction

Self-adjusting, lasts the life of the valve

SIZE (in.)	Cv	SIZE (in.)	Cv	SIZE (in.)	Cv	Standard Material	Body	Type of Material Disc	Shaft	Specifications for Materials of Construction
3"	323	10"	4458	16"	11413	Cast Iron	Cast Iron	Cast Iron 316 edge	SS, Type 304	Cast Iron: ASTM A48, Class 40 (Flanged) ASTM A126, Class B (Monoflanged)
4"	575	12"	6420	18"	14444					
6"	1294	14"	8738	20"	17832					
8"	2300	Cv values in the full open position								
										Other materials available upon request.
										Stainless Steel: ASTM A276 Type 304 (Shaft)

Butterfly Valve

SUGGESTED SPECIFICATION FOR THE DBV RUBBER SEATED BUTTERFLY VALVE, SIZES 3 THROUGH 20 INCHES

General

Butterfly valves shall be manufactured in accordance with the latest revision of AWWAC504, Class 150B and conform to NSF Standard 61. All valves shall be comply with the following details.

Valve Bodies

Valve bodies shall be constructed of ASTM A126, Class B cast iron for flanged valves or ASTM A48, Class 40 for wafer style. Flanged valves shall be fully faced and drilled in accordance with ANSI Standard B16.1, Class 125.

Valve Seats

Rubber body seats shall be of one piece construction, simultaneously molded and bonded into a recessed cavity in the valve body. Seats may not be located on the disc or be retained by segments and/or screws. For wafer style valves, the seat shall cover the entire inner surface of the valve body and extend over the outside face of the valve body to form a flange gasket.

Valve Bearings

Valve bearings shall be of a self-lubricating, nonmetallic material to effectively isolate the disc-shaft assembly from the valve body. Metal-to-metal thrust bearings in the flow stream are not allowed.

Valve Disc

The disc shall be a lens-shaped design to afford minimal pressure drop and line turbulence. Materials of construction shall be:

ASTM A126, Class B cast iron disc with a stainless steel type 316 edge

Discs shall be retained by stainless steel pins which extend through the full diameter of the shaft to withstand the specified line pressure up to valve rating and the torque required to operate the valve. Disc stops located in the flow stream are not allowed.

Valve Shafts

Valve shafts shall be of stainless steel type 304. At the operator end of the valve shaft, a packing gland utilizing "V" type chevron packing shall be utilized. "O" ring and "U" cup packing is not allowed.

Painting

All surfaces of the valve interior shall be clean, dry and free from grease before painting. The valve surfaces except for disc edge, rubber seat and finished portions shall be evenly coated with asphalt varnish in accordance with Federal Specification TT-C-494 and AWWA Standard C504. The exterior valve surfaces and actuator shall be evenly coated with a suitable primer to match field coatings.

Testing

Hydrostatic and seat leakage tests shall be conducted in strict accordance with AWWA Standard C504.

Manual Actuators

Manual actuators shall be of the traveling nut, self-locking type and shall be designed to hold the valve in any intermediate position between fully open and fully closed without creeping or fluttering. Actuators shall be equipped with mechanical stop-limiting devices to prevent overtravel of the disc in the open and closed positions. Actuators shall be fully enclosed and designed to produce the specified torque with a maximum pull of 80lb. on the handwheel or chainwheel. Actuator components shall withstand an input of 450 Ft. Lbs. at extreme operator position without damage. Manual actuators shall conform to AWWA C504.



DIMENSIONAL DATA: FLANGED BUTTERFLY VALVE

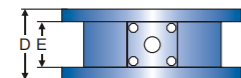
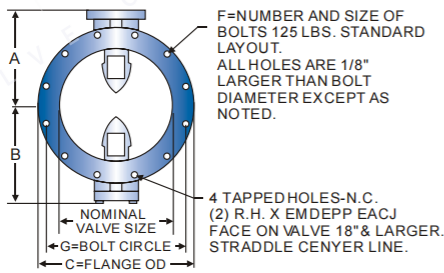

Available in sizes 3 through 20 inches

SIZE (in.)	A	B	C	D	E	F	G
3	4-3/4	3-1/4	7-1/2	5	3/4	4-5/8	6
4	5-1/2	3-1/2	9	5	15/16	8-5/8	7-1/2
6	6-1/2	5-1/8	11	5	1	8-3/4	9-1/2
8	7-3/4	6-1/2	13-1/2	6	1-1/8	8-3/4	11-3/4
10	9	9-7/8	16	8	1-3/16	12-7/8	14-1/4
12	10-1/2	11-3/8	19	8	1-1/4	12-7/8	17
14	11-7/8	12-3/4	21	8	1-3/8	12-1	18-3/4
16	13-1/2	14-3/8	23-1/2	8	1-7/16	16-1	21-1/4
18	14-3/8	15-1/4	25	8	1-9/16	16-1-1/8	22-3/4
20	16	16-7/8	27-1/2	8	1-11/16	20-1-1/8	25

DIMENSIONAL DATA: WAFFER BUTTERFLY VALVE

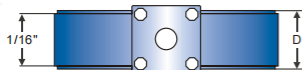
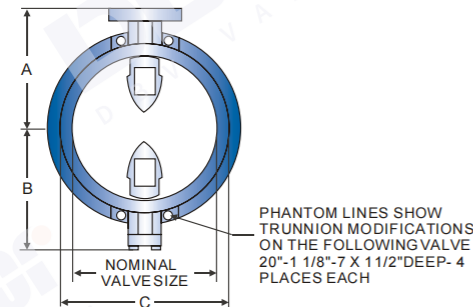

-Available in standard sizes.
-24\" Monoflange type available upon request.

SIZE (in.)	DISC O.D.	MINIMUM MATING PIPE I.D.	Size	A	B	C	D
3	3.089	2.41	3	4-3/4	3-1/4	5-1/4	2-1/16
4	4.074	3.44	4	5-1/2	3-1/2	6-3/4	2-5/16
6	6.070	5.38	6	6-1/2	5-1/8	8-5/8	2-15/16
8	8.078	7.53	8	7-3/4	6-1/2	10-7/8	3-1/16
10	10.098	9.62	10	9	9-7/8	13-1/4	3-3/16
12	12.108	11.64	12	10-1/2	11-5/16	16	3-7/16
14	13.339	12.86	14	11-7/8	12-3/4	17-5/8	3-11/16
16	15.336	14.79	16	13-1/2	14-3/8	20-1/8	4-3/16
18	17.370	16.75	18	14-3/8	15-1/4	21-1/2	4-11/16
20	19.380	18.71	20	16	16-13/16	23-3/4	5-3/16

DIMENSIONAL DATA: MECHANICAL JOINT END BUTTERFLY VALVE

Installation Diagram
Note: The following items to be furnished by others unless otherwise specified in contract:
Bolts, Glands, Nuts, Gaskets

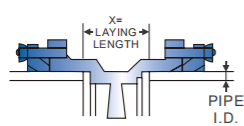
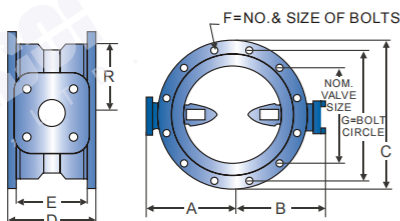

PIPE SIZE	PIPE O.D.	PIPE I.D. MIN.
4	4.80	3.10
6	6.90	5.69
8	9.05	7.65
10	11.10	9.93
12	13.20	11.70
14	15.30	12.91
16	17.40	14.91
18	19.50	16.95
20	21.60	18.96

- Available in sizes 4 through 20 inches

SIZE (in.)	A	B	C	D	E	F	G	X
4	5-1/2	3-1/2	9	8-1/8	1	4-3/4	7-1/2	3-1/8
6	6-1/2	5-1/8	11	8-1/2	1-1/16	6-3/4	9-1/2	3-1/2
8	7-3/4	6-1/2	13-1/4	8-5/8	1-1/8	6-3/4	11-3/4	3-5/8
10	9	9-3/4	15-9/16	9-1/4	1-3/16	8-3/4	14	4-1/4
12	10-1/2	11-3/8	17-15/16	9-1/4	1-1/4	8-3/4	16-1/4	4-1/4
14	11-7/8	12-3/4	20-5/16	11-1/2	1-5/16	10-3/4	18-3/4	4-1/2
16	13-1/2	14-5/16	22-9/16	12	1-3/8	12-3/4	21	5
18	14-3/8	15-3/8	24-11/16	12-1/4	1-3/8	12-3/4	23-1/4	5-1/4
20	16	17	27-3/32	12-1/2	1-1/2	14-3/4	25-1/2	5-1/2

Butterfly Valve

DIMENSIONAL DATA: MECHANICAL JOINT AND FLANGE END BUTTERFLY VALVE

Installation Diagram

Note: Bolts, Nuts, Glands and Gaskets furnished by others unless otherwise specified in contract.

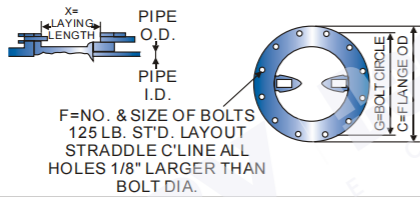
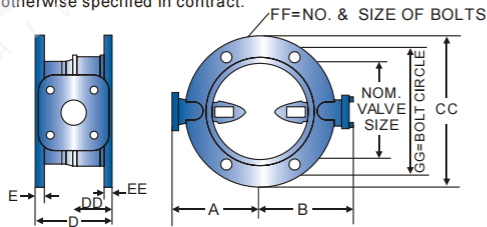

DIMENSIONAL DATA:

SIZE (in.)	A	B	C	CC	D	DD	E	EE	F	FF	G	GG	X
6	6-1/2	5-1/8	11	11	6-3/4	4-1/4	1-1/16	1-1/16	8-3/4	6-3/4	9-1/2	9-1/2	4-1/4
8	7-3/4	6-1/2	13-1/2	13-1/4	7-5/16	4-5/16	1-1/8	1-1/8	8-3/4	6-3/4	11-3/4	11-3/4	4-13/16
10	9	9-7/8	16	15-9/16	8-5/8	4-5/8	1-1/4	1-3/16	12-7/8	8-3/4	14-1/4	14-1/4	6-1/8
12	10-1/2	11-3/8	19	17-15/16	8-5/8	4-5/8	1-1/4	1-1/4	12-7/8	8-3/4	17	16-1/4	6-1/8
14	11-7/8	12-3/4	21	20-5/16	9-3/4	5-3/4	1-3/8	1-5/16	12-1	10-3/4	18-3/4	18-3/4	6-1/4
16	13-1/2	14-3/8	23-1/2	22-9/16	10	6	1-7/16	1-3/8	16-1	12-3/4	21-1/4	21	6-1/2
18	14-3/8	15-1/4	25	24-11/16	10-1/8	6-1/8	1-9/16	1-7/16	16-1-1/8	12-3/4	22-3/4	23-1/4	6-5/8
20	16	16-7/8	27-1/2	27-3/32	10-1/4	6-1/4	1-11/16	1-1/2	20-1-1/8	14-3/4	25	25-1/2	6-3/4

Unit: inch

Note 1: Min. Pipe I.D. value has zero clearance between mating pipe and valve disc. Properly sized piping must include appropriate clearance.

PIPE SIZE	PIPE O.D.	PIPE I.D. MIN.
4	4.80	3.10
6	6.90	5.69
8	9.05	7.65
10	11.10	9.93
12	13.20	11.70
14	15.30	12.91
16	17.40	14.91
18	19.50	16.95
20	21.60	18.96

-Available in sizes 6 through 20 inches.

DIMENSIONAL DATA: PUSH-ON JOINT END BUTTERFLY VALVE

Installation Diagram

Note: Rubber ring gaskets furnished by others unless otherwise specified in contract.

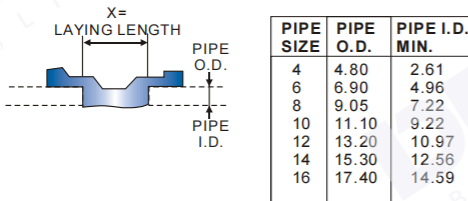
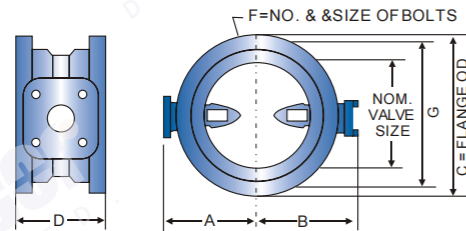

DIMENSIONAL DATA:

SIZE (in.)	A	B	C	D	X
4	5-1/2	3-1/2	6-7/8	10-3/8	3-1/8
6	6-1/2	5-1/8	9	10-3/4	3-1/2
8	7-3/4	6-1/2	11-1/4	12	3-5/8
10	9	9-7/8	14	12-5/8	4-1/8
12	10-1/2	11-3/8	16-3/8	15	5-1/8
14	11-7/8	12-3/4	18-7/8	14-3/4	4-1/2
16	13-1/2	14-3/8	21-1/4	15	4-3/4

Unit: inch

- All dimensions shown in inches.
- * - Available in sizes 4 through 16 inches.
- * - D ± 1/16" through 10" valves, ± 1/8" for 12" and larger valves.
- * - The valve end is designed for iron or PVC pipe with cast iron equivalent O.D.s (not for use with IPS O.D. pipe.)

DIMENSIONAL DATA: PUSH-ON X FLANGE END BUTTERFLY VALVE

Installation Diagram

Note: Bolts, Nuts, and Rubber Gaskets furnished by others unless otherwise specified in contract.

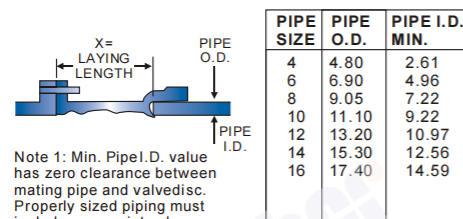
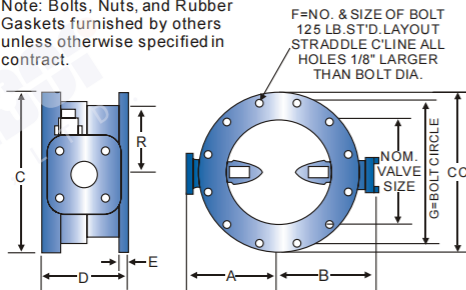

Note 1: Min. Pipe I.D. value has zero clearance between mating pipe and valve disc. Properly sized piping must include appropriate clearance.

SIZE (in.)	A	B	C	CC	D	E	F	G
4	5-1/2	3-1/2	6-7/8	9	7-11/16	15/16	8-5/8	7-1/2
6	6-1/2	5-1/8	9	11	7-7/8	1	8-3/4	9-1/2
8	7-3/4	6-1/2	11-1/4	13-1/2	8-15/16	1-1/8	8-3/4	11-3/4
10	9	9-7/8	14	16	10-5/16	1-3/16	12-7/8	14-1/2
12	10-1/2	11-3/8	16-3/8	19	11-1/2	1-1/4	12-7/8	17
14	11-7/8	12-11/16	18-7/8	21	11-3/8	1-3/8	12-1	18-3/4
16	13-1/2	14-5/16	21-1/4	23-1/2	11-1/2	1-7/16	16-1	21-1/4

Unit: inch

- All dimensions shown in inches.
- Available in sizes 4 through 12 inches.
- D ± 1/16" through 10" valves, ± 1/8" for 12" and larger valves.
- The valve end is designed for iron or PVC pipe with cast iron equivalent O.D.s (not for use with IPS O.D. pipe.)

DIMENSIONAL DATA: VICTAULIC END BUTTERFLY VALVE

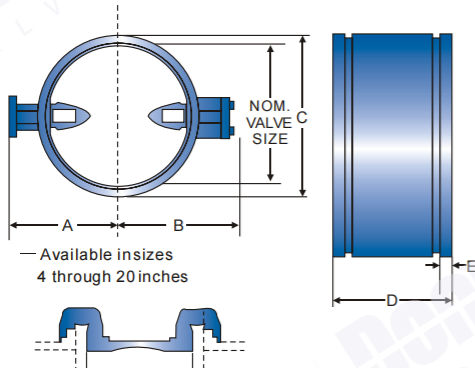

INSTALLATION DETAIL
NOTE: VICTAULIC COUPLINGS, GLANDS, AND GASKETS FURNISHED BY OTHERS

SIZE (in.)	A	B	C	D	E	Unit: inch
4	5-1/2	3-1/2	5-5/16	8-1/8	3/4	
6	6-1/2	5-1/8	7-1/2	8-1/2	3/4	
8	7-3/4	6-1/2	9-3/4	8-5/8	7/8	
10	9	9-7/8	12	8	15/16	
12	10-1/2	11-5/16	14-1/4	8	15/16	
14	11-7/8	12-11/16	16-7/16	8	15/16	
16	13-1/2	14-5/16	18-1/2	8	1-3/16	
18	14-3/8	15-3/16	20-15/16	8	1-1/4	
20	16	16-13/16	22-7/8	8	1-3/16	

All dimensions shown in inches.
"D" dimension $\pm 1/16$ " for 4" thru 10" valves.
"D" dimension $\pm 1/8$ " for 12" thru 20" valves.

ACTUATOR DIMENSIONAL DATA DBV AMG MANUAL ACTUATOR

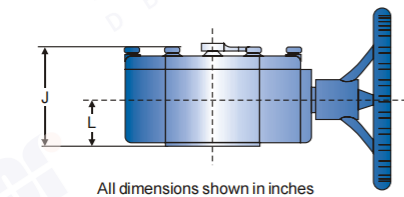

SIZE (in.)	AMG Size	J	L	M	N	P	Unit: inch
3 to 12"	AMG-2	4-11/16	2	2-1/8	2	4-1/2	
14, 16"	AMG-3	5-5/8	2-7/16	3-1/4	3-5/32	5-5/8	
18, 20"	AMG-4	6-3/8	2-27/32	3-3/8	4	7-5/16	

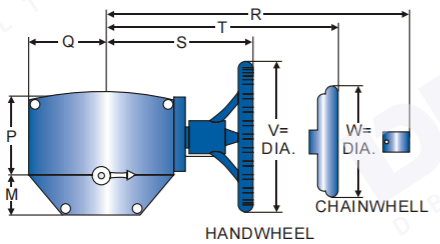

Q	R	S	T	V	W	# Turns to close	Unit: inch
4-1/4	7-5/8	7-7/8	7-7/8	8	9-1/8	32	
5-3/8	9-1/4	10-1/2	10	12	9-1/8	30	
6-3/4	10-1/2	11-1/2	11	12	9-1/8	40	

For further information regarding manual actuators, Contact DBV for more details.

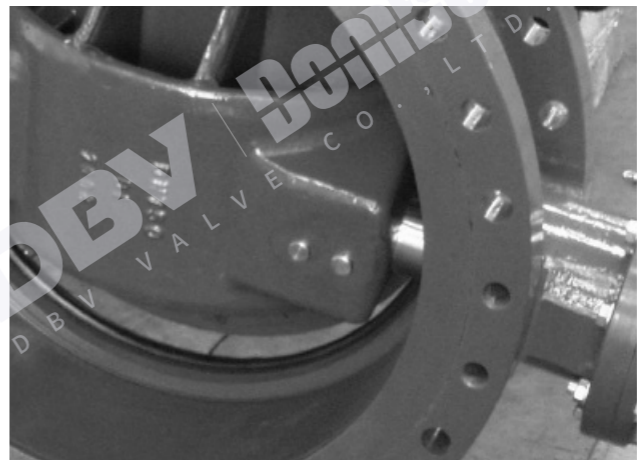
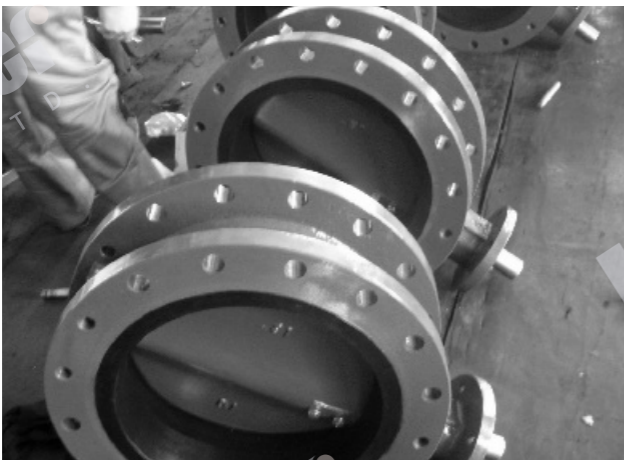

Butterfly Valve

BUTTERFLY VALVE, 125# FLANGED & MJ SPECIFICATION

General

Butterfly valves shall be manufactured in accordance with the latest revision of AWWA Standard C504 Class 250B, shall be suitable for a differential pressure of 250 psig. Valves shall be comply with the following details:

Valve Bodies

The body shall be constructed of Ductile Iron ASTM A536 Gr. 65-45-12, with flanged end connections drilled in accordance with ANSI B16.1, Class 125, Class 250, or Mechanical Joint ends. The body wall thickness shall be in strict accordance with AWWA C504.

Valve Shafts

The shaft shall be made of ASTM A-564 Type 630 condition H-1150. The shaft seals shall be "V" type packing. Shaft seals shall be of a design allowing replacement without removing the valve shaft. No O-ring or "U" cup packing shall be allowed. The bearing shall be a stainless steel backed Teflon material. Bearing load shall not exceed 1/5 of the compressible strength of the bearing or shaft material.

Valve Discs

The disc shall utilize an on-center shaft and symmetrical design, cast from Ductile Iron ASTM A536 Gr. 65-45-12. The disc edge shall be stainless steel type 316. Disc shall be retained by pins that extend through the full diameter of the shaft. The pin material shall be the same as the shaft material. Torque plugs or tangential fasteners shall not be allowed. For valve sizes 3" through 20" the rubber seat shall be of one piece construction, simultaneously molded and bonded directly into the body. The seat material shall be either Buna-N or EPDM rubber.

Valve Actuators

Manual actuators shall be of the travelling nut, self-locking type and shall be designed to hold the valve in any intermediate position between fully open and fully closed without fluttering or creeping. The actuator shall have mechanical stops that will withstand and input torque of 450 ft/lb. against each stop. Manual actuators shall conform to AWWA Standard C504.

DUCTILE IRON BODY, FLANGED X MJ 6"-16"

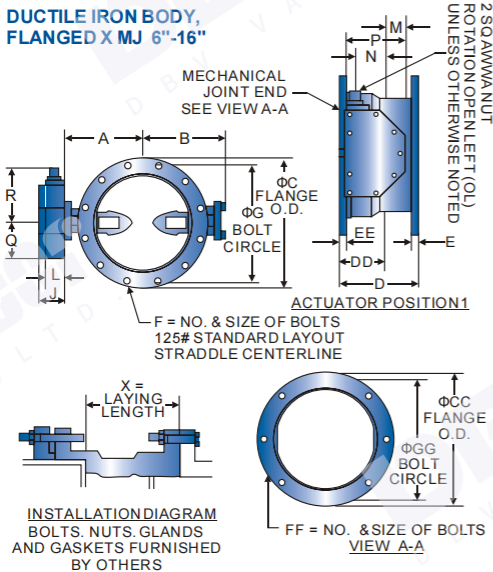

SIZE (in.)	A	B	C	CC	D	DD	E	Unit: inch
6	6-1/2	5-1/8	11	11	6-3/4	4-1/4	1-1/16	
8	7-3/4	6-1/2	13-1/2	13-1/4	7-5/16	4-5/16	1-1/8	
10	9	9-7/8	16	15-9/16	8-5/8	4-5/8	1-1/4	
12	10-1/2	11-3/8	19	17-15/16	8-5/8	4-5/8	1-1/4	
16	13-1/2	14-3/8	23-1/2	22-9/16	10	6	1-7/16	

SIZE (in.)	EE	F	FF	G	GG	X	Unit: inch
6	1-1/16	8-3/4	6-3/4	9-1/2	9-1/2	4-1/4	
8	1-1/8	8-3/4	6-3/4	11-3/4	11-3/4	4-13/16	
10	1-3/16	12-7/8	8-3/4	14-1/4	14	6-1/8	
12	1-1/4	12-7/8	8-3/4	17	16-1/4	6-1/8	
16	1-3/8	16-1	12-3/4	21-1/4	21	6-1/2	

Actuator Size	J	L	M	N	P	Q	R	Number of Turns
AMG-2S	4-11/16	2	2-1/8	2	4-1/2	4-1/2	8-1/4	32
AMG-3S	5-5/8	2-7/16	3-1/4	3-5/32	5-5/8	5-3/8	10-3/8	30
AMG-4S	6-3/8	2-27/32	3-3/8	4	7-5/16	6-3/4	11-5/16	40

DUCTILE IRON BODY, ANSI 125# FLANGED ENDS 3"-20"

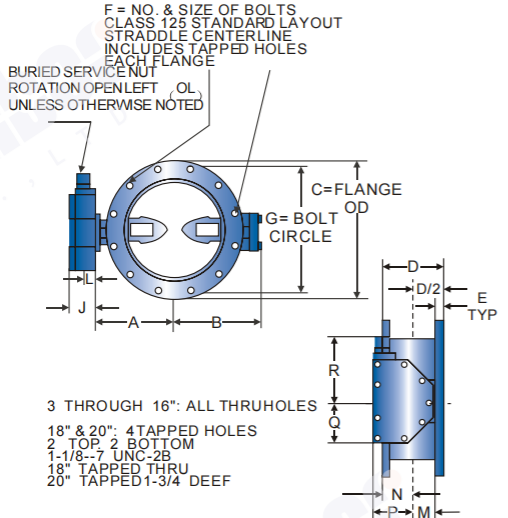

SIZE (in.)	A	B	C	D	E	F	G	Unit: inch
3	4-3/4	3-3/4	7-1/2	5	3/4	4-5/8	6	
4	5-1/2	4-1/2	9	5	15/16	8-5/8	7-1/2	
6	6-1/2	5-1/2	11	5	1	8-3/4	9-1/2	
8	7-3/4	6-3/4	13-1/2	6	1-1/8	8-3/4	11-3/4	
10	9	9-11/16	16	8	1-3/16	12-7/8	14-1/4	
12	10-1/2	11-3/16	19	8	1-1/4	12-7/8	17	
14	11-7/8	12-9/16	21	8	1-3/8	12-1	18-3/4	
16	13-1/2	14-3/16	23-1/2	8	1-7/16	16-1	21-1/4	
18	14-3/8	15-1/16	25	8	1-9/16	16-1-1/8	22-3/4	
20	16	16-11/16	27-1/2	8	1-11/16	20-1-1/8	25	

Actuator Size	Valve Size	J	L	M	N	P	Q	R	Number of Turns
AMG-2S	3-8"	4-11/16	2	2-1/8	2	4-1/2	4-1/4	8-1/4	32
AMG-3S	10-14"	5-5/8	2-7/16	3-1/4	3-5/32	5-5/8	5-3/8	10-3/8	30
AMG-4S	16&18"	6-3/8	2-27/32	3-3/8	4	7-5/16	6-3/4	11-5/16	40
AMG-5	20"	7-9/16	3-15/32	4-1/2	5-1/2	8-3/4	10	17	44

DUCTILE IRON BODY, ANSI 125# FLANGED ENDS 24"-48"

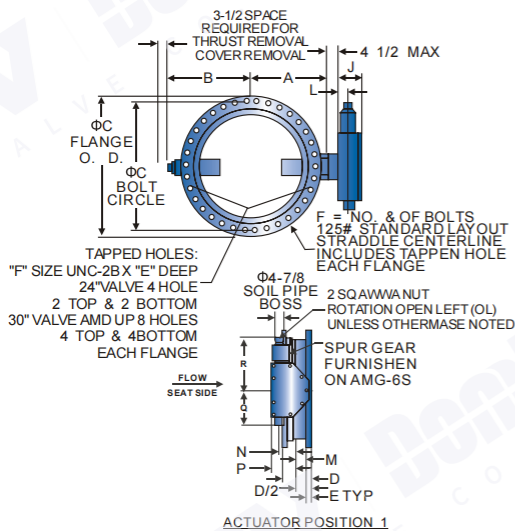

SIZE (in.)	A	B	C	D	E	F	G	Unit: inch
24	18-5/8	18-3/8	32	8	1-7/8	20/1-1/4	29-1/2	
30	21-1/2	24-1/8	38-3/4	12	2-1/8	28/1-1/4	36	
36	25-7/16	28	46	12	2-3/8	32/1-1/2	42-3/4	
42	29-7/8	32-11/16	53	12	2-5/8	36/1-1/2	49-1/2	
48	34-1/16	36-7/8	59-1/2	15	2-3/4	44/1-1/2	56	

Actuator Size	J	L	M	N	P	Q	R	Number of Turns	Unit: inch
AMG-5	7-9/16	3-15/32	4-1/2	5-1/2	8-3/4	10	17	44	
AMG-5S	8-5/16	3-15/16	5-1/2	7	10-1/2	15-15/16	19-7/8	136	
AMG-6S	9-7/8	5-1/16	7	8-1/4	12-5/8	14-3/16	16-1/2	215	

DUCTILE IRON BODY, MECHANICAL JOINT 4"-20"

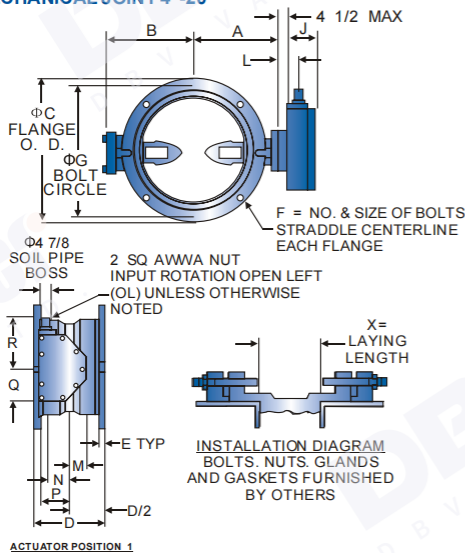

SIZE (in.)	A	B	C	D	E	F	G	X	Unit: inch
4	5-1/2	3-1/2	9	8-1/8	1	4-3/4	7-1/2	3-1/8	
6	6-1/2	5-1/8	11	8-1/2	1-1/16	6-3/4	9-1/2	3-1/2	
8	7-3/4	6-1/2	13-1/4	8-5/8	1-1/8	6-3/4	11-3/4	3-5/8	
10	9	9-3/4	15-9/16	9-1/4	1-3/16	8-3/4	14	4-1/4	
12	10-1/2	11-3/8	17-15/16	9-1/4	1-1/4	8-3/4	16-1/4	4-1/4	
14	11-7/8	14-3/4	20-5/16	11-1/2	1-5/16	10-3/4	18-3/4	4-1/2	
16	13-1/2	14-1/2	22-9/16	12	1-3/8	12-3/4	21	5	
18	14-3/8	15-3/8	24-11/16	12-1/4	1-3/8	12-3/4	23-1/4	5-1/4	
20	16	17	27-3/32	12-1/2	1-1/2	14-3/4	25-1/2	5-1/2	

Actuator Size	Valve Size	J	L	M	N	P	Q	R	Number of Turns	Unit: inch
AMG-2S	3-8"	4-11/16	2	2-1/8	2	4-1/2	4-1/4	8-1/4	32	
AMG-3S	10-14"	5-5/8	2-7/16	3-1/4	3-5/32	5-5/8	5-3/8	10-3/8	30	
AMG-4S	16&18"	6-3/8	2-27/32	3-3/8	4	7-5/16	6-3/4	11-5/16	40	
AMG-5	20"	7-9/16	3-15/32	4-1/2	5-1/2	8-3/4	10	17	44	

DUCTILE IRON BODY, MECHANICAL JOINT 24"-48"

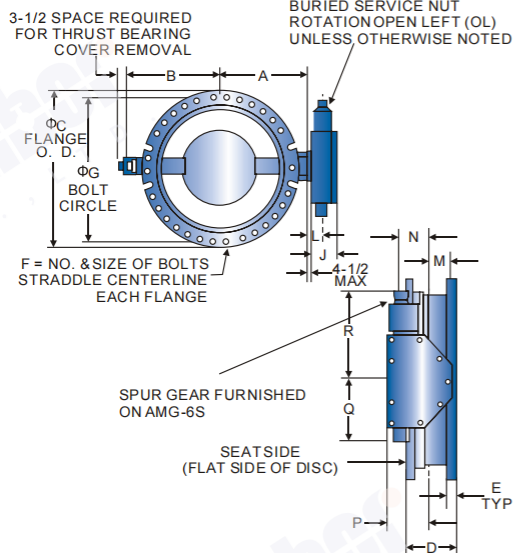

SIZE (in.)	A	B	C	D	E	F	G	X	Unit: inch
20	18-5/8	18-5/8	31-9/16	13-1/4	1-5/8	16-3/4	30	6-3/8	
30	21-1/2	24-3/8	39	18	1-13/16	20-1	36-7/8	10	
36	25-7/16	28-1/4	45-7/8	22	2	24-1	43-3/4	14	
42	29-7/8	32-7/8	53	22	2	28-1-1/4	50-5/8	14	
48	34-1/16	37-1/8	59-7/8	24	2	32-1-1/4	57-1/2	16	

Actuator Size	J	L	M	N	P	Q	R	Number of Turns	Unit: inch
AMG-4S	6-3/8	3-7/16	3-3/8	4	7-5/16	6-3/4	11-5/16	40	
AMG-5	7-9/16	3-1/2	4-1/2	5-1/2	8-3/4	10-7/16	17	44	
AMG-5S	8-5/16	3-15/16	5-5/8	7	10-5/8	15-15/16	19-7/8	136	
AMG-6S	9-7/8	5-1/16	7	8-1/4	12-5/8	18-5/8	26-1/2	215	

Butterfly Valve

250# FLANGED ENDS SPECIFICATION

BUTTERFLY VALVE

Class 250 For Buried Service

Valves shall be manufactured with a 250 psirating. The valves shall be capable of operating at pressures of 250 psi and will comply with the following details:

Valve Bodies shall be constructed of ductile iron ASTM A-536. End connections shall be ANSI Class 250 with 250# drilling pattern.

Valve Discs shall be made from ductile iron ASTM A-536. Discs shall be furnished with 316 stainless steel seating edge to mate with the rubber seat.

Valve Seat shall be Buna-N rubber located on the valve body.

Valve Shafts shall be stainless steel ASTM A-564 Type 630 Condition H-1150. Stub shafts or through shafts are acceptable.

Shaft Seals shall be standard self-adjusting split "V" type packing. Shaft seals shall be of a design allowing replacement without removing the valve shaft.

Valve Bearings

Valve bearings shall be sleeve type that are corrosion resistant and self-lubricating.

Valve Actuators

Valve actuators shall be fully grease packed and have stops in the open/closed position. The actuator shall have a mechanical stop which will withstand an input torque of 450 ft/lbs. against the stop. The traveling nut shall engage alignment grooves in the housing. The actuators shall have a built in packing leak bypass to eliminate possible leakage into the actuator housing.

Valve Interior and Exterior Surfaces except for seating shall be coated with two coats of epoxy paint in accordance with TT-C-494A and AWWA C504 latest edition.

All Valves shall be hydrostatic and leak tested. The leak test shall be performed at a differential pressure of 250 psi with the disc in a closed position. In a slightly open position, internal hydrostatic pressure equal to 500 psi shall be applied to the inside of the valve body for five minutes.

SCOPE OF LINE: Class 250B BUTTERFLY VALVE



SIZES:
4" through 48"

BODY STYLE:
Flanged, 250#

PRESSURE CLASS:
AWWA 250 B

ACTUATION OPTIONS*:
Nut
Handwheel
Buried Service
*Consult factory for other end connections and acceptance options

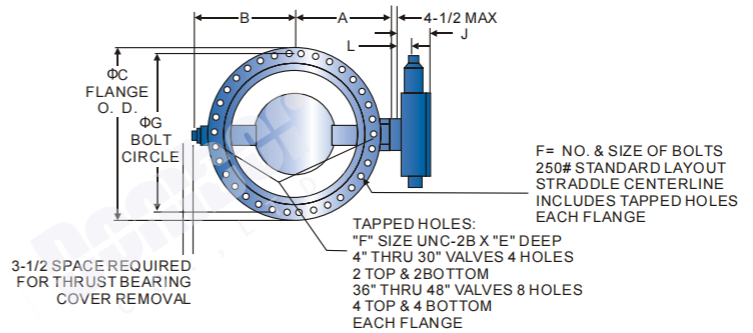

Actuator Size	J	L	M	N	P	Q	R	Number of Turns
AMG-2S	4-11/16	2	2-1/8	2	4-1/2	4-1/2	8-1/4	32
AMG-3S	5-5/8	2-7/16	3-1/4	3-5/32	5-5/8	5-3/8	10-3/8	30
AMG-4S	6-3/8	2-27/32	3-3/8	4	7-5/16	6-3/4	11-5/16	40
AMG-5	7-9/16	3-15/32	4-1/2	5-1/2	8-3/4	10	17	44
AMG-5S	8-5/16	3-15/16	5-1/2	7	10-1/2	5-15/16	19-7/8	136
AMG-6S	10-3/16	5-1/16	7	8-1/4	12-5/8	14-3/16	26-1/2	215

CAST OR DUCTILE IRON, ANSI 250# FLANGED, 250# DRILL, 4"-48"

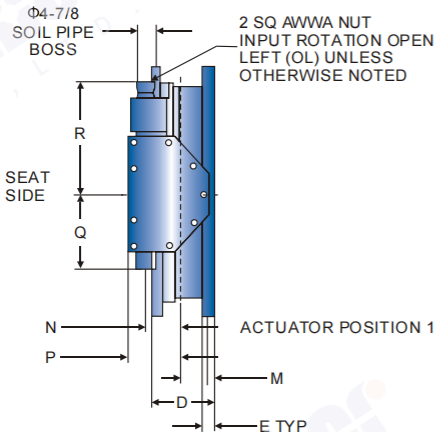

SIZE (in.)	A	B	C	D	E	F	G
4	5-1/2	3-1/2	10	5	1-1/4	8-3/4	7-7/8
6	7-1/4	8-3/8	12-1/2	6	1-7/16	12-3/4	10-5/8
8	8-1/2	9-5/8	15	8	1-5/8	12-7/8	13
10	9-3/4	11	17-1/2	8	1-7/8	16-1	15-1/4
12	11-1/2	12-5/8	20-1/2	8	2	16-1-1/8	17-3/4
14	12-3/4	13-7/8	23	12	2-1/8	20-1-1/8	20-1/4
16	14	15-1/8	25-1/2	12	2-1/4	20-1-1/4	22-1/2
18	15-1/4	16-3/8	28	12	2-3/8	24-1-1/4	23-3/4
20	17	17-5/8	30-1/2	12	2-1/2	24-1-1/4	27
24	19-3/4	20-1/4	36	12	2-3/4	24-1-1/2	32
30	25-5/8	26	43	12	8	21-1-3/4	39-1/4
36	28-1/8	31-1/8	50	15	3-3/8	32-2	46
42	32-1/8	35-1/8	57	15	3-11/16	36-2	52-3/4
48	36-1/4	39-5/8	65	15	4	40-2	60-3/4

DESIGN DETAILS 4" - 20" BURIED SERVICE BUTTERFLY VALVE

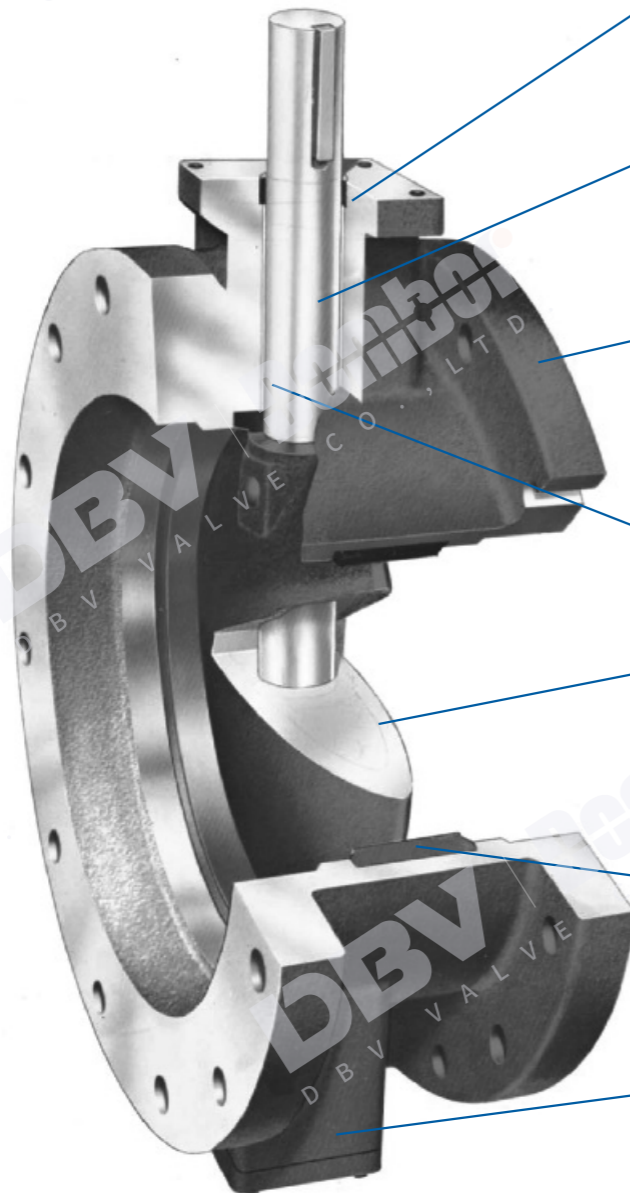

CHEVRON V PACKING

Packing is self-adjusting, long lasting and should never need replacement because quarter-turn valve operation causes little or no wear. Packing bears on turned, ground and polished stainless steel.

CORROSION RESISTANT SHAFT

To prevent corrosion of a vital structural component, shaft is constructed of Type 304 stainless steel which affords protection against the harmful effects of corrosion. Shaft is one-piece, through-shaft construction sized to meet or exceed requirements of AWWA Standard C504 for Class 150B service.

HEAVY DUTY BODY

Cast iron body is extra heavy with flanges fully faced and drilled per ANSIB16.1 Class 125 Standard for cast-iron flanges. Other ends, including integrally cast mechanical joint, push-on (for DI and PVC C900), wafer, and Victaulic coupling ends are also available. Operator mounting trunnion is machined and drilled for four bolt connection.

SELF-LUBRICATING BEARINGS

Chemically inert nylon bearings, liberally sized, are self-lubricating. These bearings should outlast the life of the pipeline.

STREAMLINED DISC

Lens-shaped disc is designed to minimize pressure drop and turbulence. Full open valve creates no more friction loss than a 45° elbow. Disc is secured to the shaft by stainless steel pins sized to transmit torques required and withstand stresses imposed under severe operating conditions. Disc is cast iron ASTM A126 Class B with Type 316 stainless steel disc edge.

BODY SEAT

Seat is bonded to the body by a special machinery process. The result is a seat that cannot be torn from the body under normal pipeline conditions. The precision molding process also insures that the disc-seat indentation cannot cause excessive wear or abrasion upon closing.

TAMPER-PROOF DISC CENTERING

Precision molded flats in the bonded seat at the body trunnion mate with machined flats on the disc to provide tamper-proof centering of the disc in the body. Positive disc alignment without play is maintained, assuring long seat life.

TECHNICAL DATA

SIZES:

4" through 20"

BODY STYLE:

Cast iron with ends for Flange, Mechanical Joint, Wafer and Victaulic couplings. Push on joint (12", 16") and Push on x Flange (12", 16") for C900 PVC and ductile iron pipe.

PRESSURE CLASS:

*Class 150B per AWWA Standard C504

ACTUATORS:

DBV traveling nut design actuator in strict compliance with AWWAC504 latest revision. Specially designed and built for buried service.

ACCESSORIES:

Position indicator, handwheel, extension stem valve box (standard and slip joint).

AWWA CLASS 150 B BURIED SERVICE

SIZE (in.)	End Connection
4" - 48"	M/J x M/J
3" - 72"	Flg x Flg
6" - 36"	Flg x M/J
12", 16"	Push on x Push on
24" - 54"	Victaulic
12", 16"	Push on x Flg

For end connections other than those listed, please contact DBV.

Butterfly Valve

DESIGN DETAILS 24" - 72" BURIED SERVICE BUTTERFLY VALVES

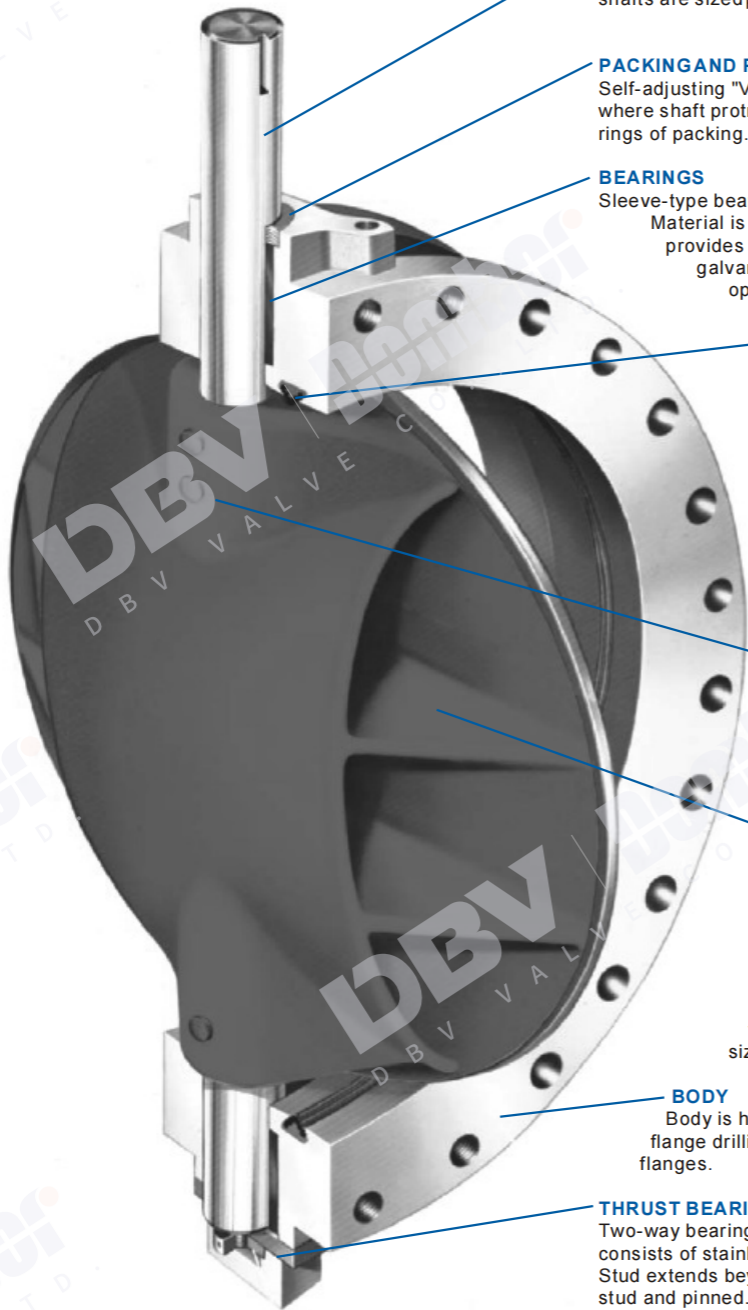

CORROSION-RESISTANT SHAFTS

Constructed of ASTM A-276 Type 304 stainless steel. Two-piece, stubtype shafts are sized per AWWA Standard C504, Class 150B.

PACKING AND PACKING GLAND ASSEMBLIES

Self-adjusting "V" type packing, utilized only in top trunnion of valve body where shaft protrudes, incorporates nylon retainer followed by several rings of packing.

BEARINGS

Sleeve-type bearings are used in both trunnions of the valve body. Material is Teflon-lined with special non-metallic backing. This provides electrical insulation between disc and shaft to prevent galvanic corrosion. Lower coefficient of friction cuts down operating torque requirements.

RUBBER SEAT

Specially compounded Buna-N seat seals a full 360° against a stainless steel spherical disc edge. Unique grooved-seat design, coupled with the wide, spherically shaped seating edge of the disc, allows greater disc closure tolerance (up to 1° off center in closed position without leakage). Seat is mechanically retained in body without metal hardware by a cast epoxy compound that insures the seat conforms to the exact radius of the disc with uniform contact pressure.

SHAFT CONNECTIONS

Disc and shaft are connected together by generously sized stainless steel pins designed to transmit torques required and withstand stresses imposed under severe operating conditions.

FLOW-THROUGH DISC

Provides less pressure drop in full-open position than conventional disc shapes. On 24" size the arch side of disc is closed and the flat side is open, forming slightly concave surface. Disc structure is safer, with no internal cores that can shift during casting and no hollow chambers that can collect water, later freeze and fracture the disc. Material is ductile iron with stainless steel spherically shaped seating surface. In sizes 24" through 72", ductile iron ASTM A-536 is used.

BODY

Body is heavy cast iron ASTM A-126. On flange-end bodies, flange drilling is per ANSIB 16.1 Class 125 Standard for cast iron flanges.

THRUST BEARING ASSEMBLY

Two-way bearing is preset at factory. On valves 30" and larger, assembly consists of stainless steel stud fastened to the bottom of the valve shaft. Stud extends beyond the bottom cover. Thrust collar is threaded to the stud and pinned. On 24" size, thrust collar is pinned to shaft and adjustment provided by bronze spacers. Thrust-collar cavity is packed with grease and fully gasketed to prevent leakage.

TECHNICAL DATA

SIZES:

24" through 72"

BODY STYLE:

Cast iron with ends for flanges, mechanical joints, Victaulic couplings and concrete pipe.

PRESSURE CLASS:

*Class 150B per AWWA Standard C504

ACTUATORS:

DBV traveling nut design actuator in strict compliance with AWWA C504 latest revision. Specially designed and built for buried service.

SERVICE:

Distribution, potable or raw water.

ACCESSORIES:

Position indicator, handwheel, extension stem, valve box (standard and slipjoint).

DIMENSIONAL DATA FLANGED 3" - 20"

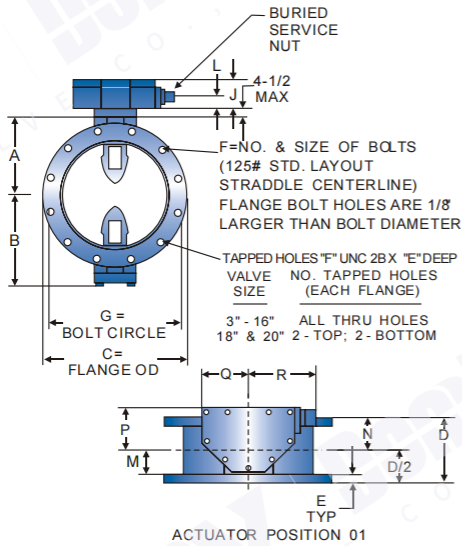

SIZE (in.)	A	B	C	D	E	F	G	Unit:inch
3	4-3/4	3-1/4	7-1/2	5	3/4	4-5/8	6	
4	5-1/2	3-1/2	9	5	15/16	8-5/8	7-1/2	
6	6-1/2	5-1/8	11	5	1	8-3/4	9-1/2	
8	7-3/4	6-1/2	13-1/2	6	1-1/8	8-3/4	11-3/4	
10	9	9-7/8	16	8	1-3/16	12-7/8	14-1/4	
12	10-1/2	11-3/8	19	8	1-1/4	12-7/8	17	
14	11-7/8	12-3/4	21	8	1-3/8	12-1	18-3/4	
16	13-1/2	14-3/8	23-1/2	8	1-7/16	16-1	21-1/4	
18	14-3/8	15-1/4	25	8	1-9/16	16-1-1/8	22-3/4	
20	16	16-7/8	27-1/2	8	1-11/16	20-1-1/8	25	

Actuator Size	J	L	M	N	P	Q	R	Unit:inch
AMG-2S	4-11/16	2	2-1/8	2	4-1/2	4-1/4	8-1/4	
AMG-3S	5-5/8	2-7/16	3-1/4	3-5/32	5-5/8	5-3/8	10-3/8	
AMG-4S	6-3/8	2-27/32	3-3/8	4	7-5/16	6-3/4	11-5/16	
AMG-5	7-9/16	3-15/32	4-1/2	5-1/2	8-3/4	10	17	

FLANGED 24" - 48"

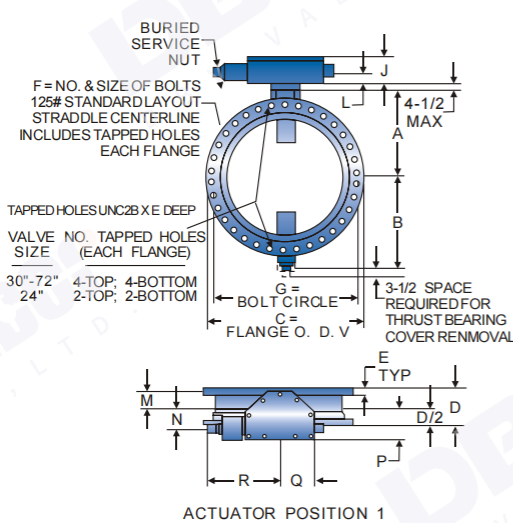

SIZE (in.)	25 & 75 PSI		150 PSI		C	D	E	F	G	Unit:inch
	A	B	A	B						
24	—	—	18-5/8	18-3/8	32	8	1-7/8	20-1-1/4	29-1/2	
30	21-9/16	22-3/4	21-1/2	24-1/8	38-3/4	12	2-1/8	28-1-1/4	36	
36	25-1/16	26-1/2	25-7-16	28	46	12	2-3/8	32-1-1/2	42-3/4	
42	29-1/16	30-3/8	29-7/8	32-11/16	53	12	2-5/8	36-1-1/2	49-1/2	
48	32-5/16	34-5/8	34-1/16	36-7/8	59-1/2	15	2-3/4	44-1-1/2	56	

Actuator Size	J	L	M	N	P	Q	R	Unit:inch
AMG-3S	5-5/8	2-7/16	3-1/4	3-5/32	5-5/8	5-3/8	10-3/8	
AMG-4S	6-3/8	2-27/32	3-3/8	4	7-5/16	6-3/4	11-5/16	
AMG-5	7-9/16	3-15/16	4-1/2	5-1/2	8-3/4	10	17	
AMG-5S	8-5/16	3-15/16	5-1/2	7	10-1/2	14-3/14	19-7/8	
AMG-6S	10-3/16	5-1/16	7	8-1/4	12-5/8	15-15/16	26-1/2	

MECHANICAL JOINT 4" - 20"

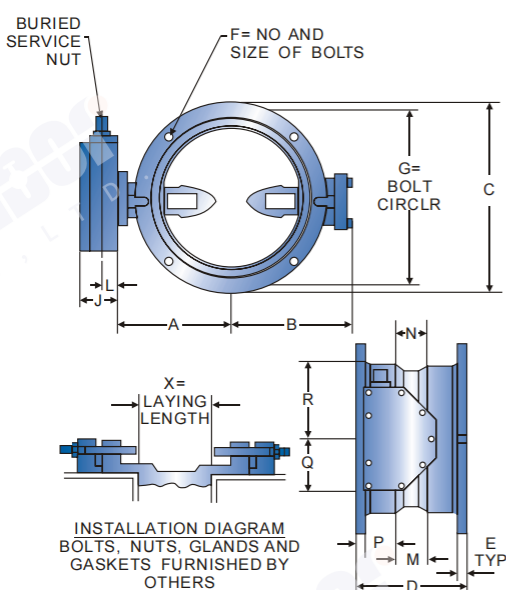

SIZE (in.)	A	B	C	D	E	F	G	X	Unit:inch
4	5-1/2	3-1/2	9	8-1/8	1	4-3/4	7-1/2	3-1/8	
6	6-1/2	5-1/8	11	8-1/2	1-1/16	6-3/4	9-1/2	3-1/2	
8	7-3/4	6-1/2	13-1/4	8-5/8	1-1/8	6-3/4	11-3/4	3-5/8	
10	9	9-3/4	15-9/16	9-1/4	1-3/16	8-3/4	14	4-1/4	
12	10-1/2	11-3/8	17-15/16	9-1/4	1-1/4	8-3/4	16-1/4	4-1/4	
14	11-7/8	12-3/4	20-5/16	11-1/2	1-5/16	10-3/4	18-3/4	4-1/2	
16	13-1/2	14-1/2	22-9/16	12	1-3/8	12-3/4	21	5	
18	14-3/8	15-3/8	24-11/16	12-1/4	1-3/8	12-3/4	23-1/4	5-1/4	
20	16	17	27-3/32	12-1/2	1-1/2	14-3/4	25-1/2	5-1/2	

Actuator Size	J	L	M	N	P	Q	R	Unit:inch
AMG-2S	4-11/16	2	2-1/8	2	4-1/2	4-1/4	8-1/4	
AMG-3S	5-5/8	2-7/16	3-1/4	3-5/32	5-5/8	5-3/8	10-3/8	
AMG-4S	6-3/8	2-27/32	3-3/8	4	7-5/16	6-3/4	11-5/16	
AMG-5	7-9/16	3-15/32	4-1/2	5-1/2	8-3/4	10	17	

Butterfly Valve

MECHANICAL JOINT 24" - 48"

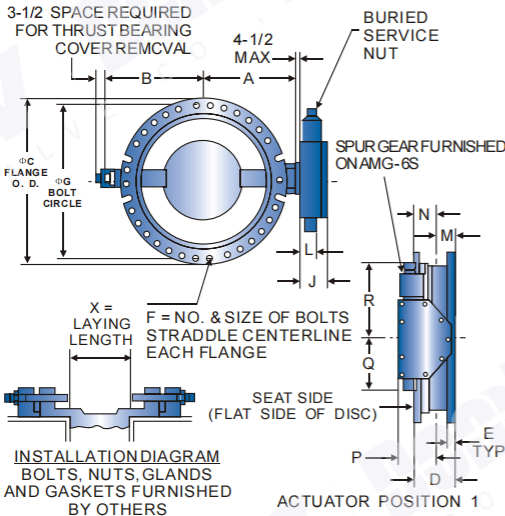

SIZE (in.)	A	B	C	D	E	F	G	X
24	18-5/8	18-5/8	31-9/16	13-1/4	1-5/8	16-3/4	30	6-3/8
30	21-1/2	24-3/8	39	18	1-13/16	20-1	36-7/8	10
36	25-7/16	28-1/4	45-7/8	22	2	24-1	43-3/4	14
42	29-7/8	32-7/8	53	22	2	28-1-1/4	50-5/8	14
48	34-1/16	37-1/8	59-7/8	24	2	32-1-1/4	57-1/2	16

Actuator Size	J	L	M	N	P	Q	R
AMG-2S	4-11/16	2	2-1/8	2	4-1/2	4-1/4	8-1/4
AMG-3S	5-5/8	2-7/16	3-1/4	3-5/32	5-5/8	5-3/8	10-3/8
AMG-4S	6-3/8	3-7/16	3-3/8	4	7-5/16	6-3/4	11-5/16
AMG-5	7-9/16	3-1/2	4-1/2	5-1/2	8-3/4	10-7/16	17
AMG-5S	8-5/16	3-15/16	5-5/8	7	10-5/8	15-15/16	19-7/8
AMG-6S	11-1/8	5-1/16	7	8-1/4	12-5/8	18-5/8	26-1/2

FLANGED X MECHANICAL JOINT 6" - 20"

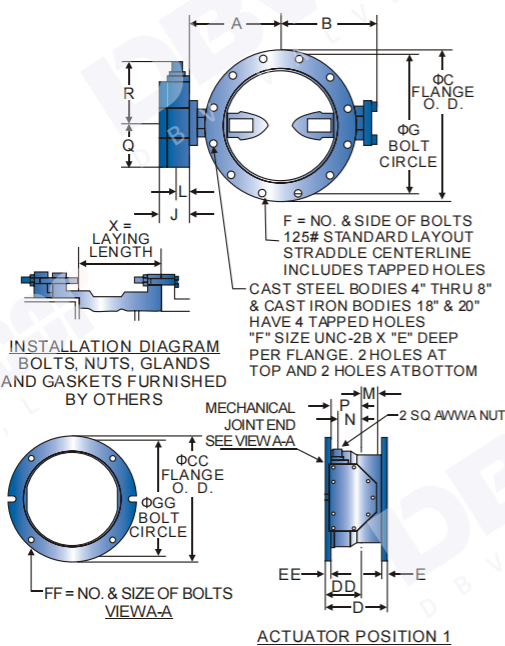

SIZE (in.)	A	B	C	CC	D	DD	E
6	6-1/2	5-1/8	11	11	6-3/4	4-1/4	1-1/16
8	7-3/4	6-1/2	13-1/2	13-1/4	7-5/16	4-5/16	1-1/8
10	9	9-7/8	16	15-9/16	8-5/8	4-5/8	1-1/4
12	10-1/2	11-3/8	19	17-15/16	8-5/8	4-5/8	1-1/4
14	11-7/8	12-3/4	21	20-5/16	9-3/4	5-3/4	1-3/8
16	13-1/2	14-3/8	23-1/2	22-9/16	10	6	1-7/16
18	14-3/8	15-1/4	25	24-11/16	10-1/8	6-1/8	1-9/16
20	16	16-7/8	27-1/2	27-3/32	10-1/4	6-1/4	1-11/16

SIZE (in.)	EE	F	FF	G	GG	X
6	1-1/16	8-3/4	6-3/4	9-1/2	9-1/2	4-1/4
8	1-1/8	8-3/4	6-3/4	11-3/4	11-3/4	4-13/16
10	1-3/16	12-7/8	8-3/4	14-1/4	14	6-1/8
12	1-1/4	12-7/8	8-3/4	17	16-1/4	6-1/8
14	1-5/16	12-1	10-3/4	18-3/4	18-3/4	6-1/4
16	1-3/8	16-1	12-3/4	21-1/4	21	6-1/2
18	1-7/16	16-1-1/8	12-3/4	22-3/4	23-1/4	6-5/8
20	1-1/2	20-1-1/8	14-3/4	25	25-1/2	6-3/4

Actuator Size	J	L	M	N	P	Q	R
AMG-2S	4-11/16	2	2-1/8	2	4-1/2	4-1/2	8-1/4
AMG-3S	5-5/8	2-7/16	3-1/4	3-5/32	5-5/8	5-3/8	10-3/8
AMG-4S	6-3/8	2-27/32	3-3/8	4	7-5/16	6-3/4	11-5/16
AMG-5	7-9/16	3-15/32	4-1/2	5-1/2	8-3/4	10	17

FLANGED X MECHANICAL JOINT 24" - 36"

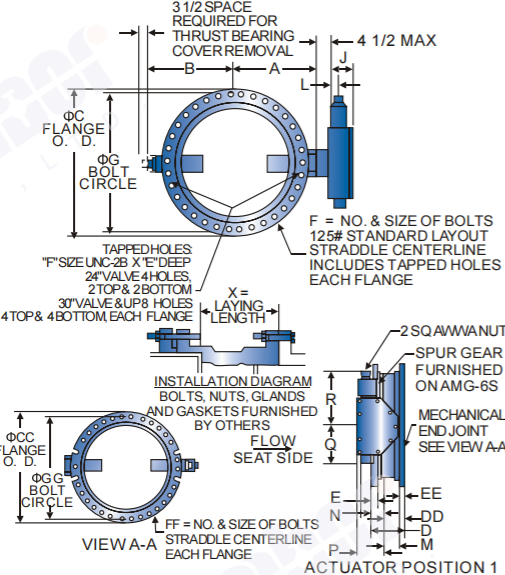

SIZE (in.)	A	B	C	CC	D	DD	E
24	18-5/8	18-5/8	32	31-9/16	10-5/8	6-5/8	1-7/8
30	21-1/2	24-3/8	38-3/4	39	15	9	2-1/8
36	25-7/16	28-1/4	46	45-7/8	17	11	2-3/8

SIZE (in.)	EE	F	FF	G	GG	X
24	1-5/8	20-1-1/4	16-3/4	29-1/2	30	7-1/8
30	1-13/16	28-1-1/4	20-1	36	36-7/8	11
36	2	32-1-1/2	24-1	42-3/4	43-3/4	13

Actuator Size	J	L	M	N	P	Q	R
AMG-4S	6-3/8	2-27/32	3-3/8	4	7-5/16	6-3/4	11-5/16
AMG-5	7-9/16	3-15/32	4-1/2	5-1/2	8-3/4	10	17
AMG-5S	8-5/16	3-15/16	5-1/2	7	10-1/2	15-15/16	19-7/8
AMG-6S	10-3/16	5-1/16	7	8-1/4	12-5/8	14-3/16	26-1/2

PUSH-ON JOINT ENDS 12", 16"

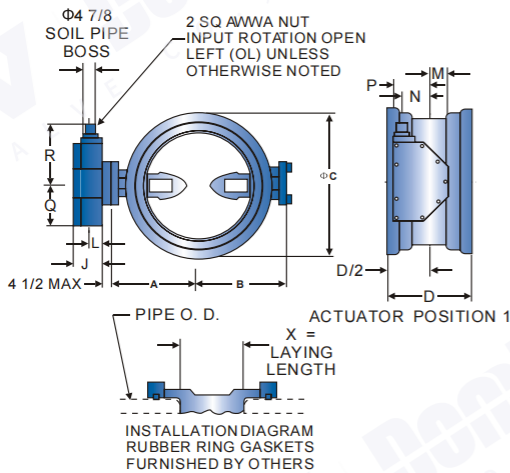

Pipe Size	Pipe O.D.	Min Mating I.D.	Valve Size	A	B	C	D	X
12	13.20	10.97	12	10-1/2	11-3/8	16-3/8	15	5-1/8
16	17.80	14.59	16	13-1/2	14-1/2	21-1/4	15	4-3/4

Unit: inch

Actuator Size	J	L	M	N	P	Q	R
AMG-2S	4-11/16	2	2-1/8	2	4-1/2	4-1/2	8-1/4
AMG-3S	5-5/8	2-7/16	3-1/4	3-5/32	5-5/8	5-3/8	10-3/8
AMG-4S	6-3/8	2-27/32	3-3/8	4	7-5/16	6-3/4	11-5/16
AMG-5	7-9/16	3-15/32	4-1/2	5-1/2	8-3/4	10	17

Unit: inch

PUSH-ON X FLANGE 12", 16"

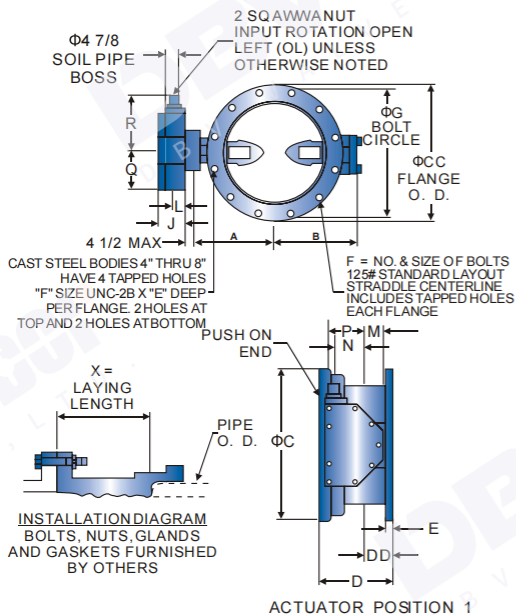

SIZE (in.)	A	B	C	CC	D	DD	E	F	G	X
12	10-1/2	11-3/8	16-3/8	19	11-1/2	4	1-1/4	12-7/8	17	6-9/16
16	13-1/2	13-7/8	21-3/4	23-3/4	11-1/2	4	1-7/16	16-1	21-1/4	9-3/16

Unit: inch

Actuator Size	J	L	M	N	P	Q	R
AMG-2S	4-11/16	2	2-1/8	2	4-1/2	4-1/2	8-1/4
AMG-3S	5-5/8	2-7/16	3-1/4	3-5/32	5-5/8	5-3/8	10-3/4
AMG-4S	6-3/8	2-27/32	3-3/8	4	7-5/16	6-3/4	11-5/16
AMG-5	7-9/16	3-15/32	4-1/2	5-1/2	8-3/4	10	17

Unit: inch

VICTAULIC 24" - 54"

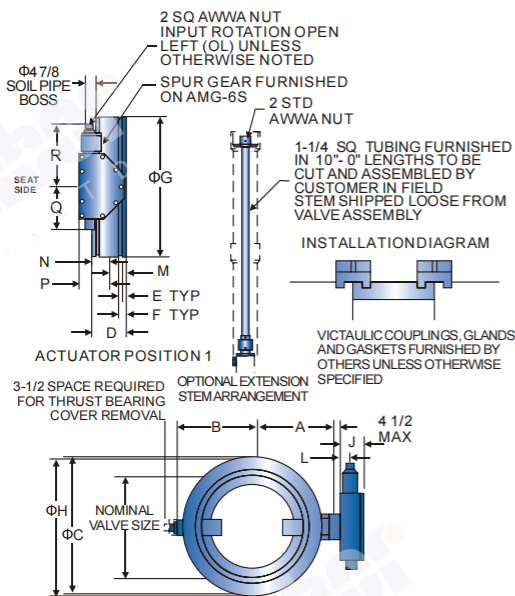

SIZE (in.)	A	B	C	D	E	F	G	H
24	18-5/8	18-3/8	27-1/8	12-1/2	1-3/16	2-3/16	26-19/32	26
30	21-1/2	24-3/16	33-3/4	18	1-3/4	2-25/32	33	34-1/8
36	25-7/16	28-1/16	40-3/16	22	1-3/4	2-25/32	39-7/16	40-9/16
42	29-7/8	32-11/16	46-5/8	22	1-3/4	3-1/32	45-13/16	47-1/8
48	34-1/16	36-7/8	53-1/8	24	1-3/4	3-1/32	52-3/16	53-5/8
54	37-1/2	40-11/16	59-11/16	24	1-3/4	3-9/32	58-5/8	60-3/16

Unit: inch

Actuator Size	J	L	M	N	P	Q	R
AMG-4S	6-3/8	2-27/32	3-3/8	4	7-5/16	6-3/4	11-5/16
AMG-5	7-9/16	3-15/32	4-1/2	5-1/2	8-3/4	10	17
AMG-5S	8-5/16	3-15/16	5-1/2	7	10-1/2	15-15/16	19-7/8
AMG-6S	10-3/16	5-1/16	7	8-1/4	12-5/8	14-3/16	26-1/2

Unit: inch

Butterfly Valve

DIMENSIONAL DATA: API STANDARD BUTTERFLY VALVE, FLANGED ENDS

DESIGN FEATURES

Design standard	API609,MSS-67-1982
Face to face	ASME B16.10
End flange	ASME B16.5
Inspection and test	API598

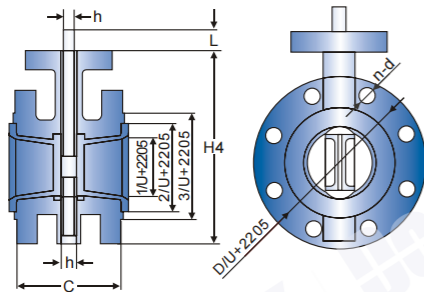

SIZE (DN)	1	2	3	H4	C	H	H1	D	N-d	L
50	59	95	105	175	108	23	17.45	125	4-19	30
65	69.8	114	122	190	112	23	17.45	145	4-19	30
80	86.4	128	138	214	114	23	20.26	160	8-19	30
100	116	150	160	226	127	25	23.8	180	8-19	30
125	133	178	186	264	140	30	28.58	210	8-19	30
150	165	200	216	319	140	30	23.8	240	8-19	30
200	212	262	272	385	152	36	34.93	295	8-23	30
250	262	310	320	448.5	165	40	38.10	355	12-23	40
300	313	364	376	518	178	46	38.10	410	12-28	40
350	344	415	429	564	190	50	39.7	470	12-28	45
400	400	460	478	633	216	68	44.45	525	16-28	70
450	452	510	530	695	222	76	47.65	585	16-31	70
500	503.6	560	582	778	229	92	57.15	650	20-31	80
600	604	660	682	890	267	97	69.9	770	20-37	80
700	706	770	794	1050	292	100	69.9	840	24-37	80
800	806.6	871	901	1180	316	100	84.9	950	24-40	80
900	877	972	1001	1240.5	330	108	95	1050	28-40	118
1000	977	1080	1112	1398	410	135	115	1170	28-43	142
1200	1156.1	1270	-	-	470	-	-	1390	32-48	142

DIMENSIONAL DATA: API STANDARD BUTTERFLY VALVE, WAFER LUG

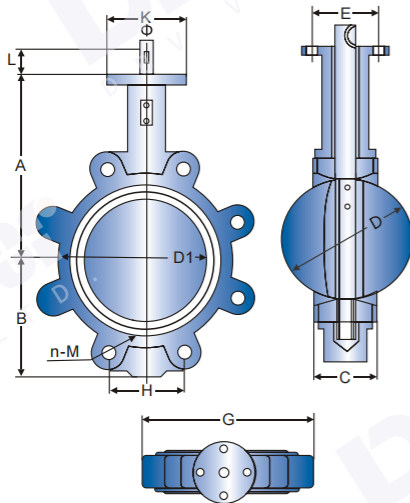

SIZE (DN)	A	B	C	D	L	K	E	φ	G
50	161	80	42	52.9	32	77	57.2	12.6	118
65	175	89	44.7	64.5	32	77	57.2	12.6	137
80	181	95	45.2	78.8	32	77	57.2	12.6	178
100	200	114	52.1	104	32	92	69.9	15.7	206
125	213	127	54.4	123.3	32	92	69.9	18.9	238
150	226	139	55.8	155.6	32	92	69.9	18.9	266
200	260	275	60.6	202.5	45	115	88.9	22.1	329
250	292	203	65.6	250.5	45	115	88.9	28.5	393
300	337	242	76.9	301.6	45	140	108	31.6	462
350	368	267	76.5	333.3	45	140	108	31.6	515
400	400	309	86.5	389.6	51.2	197	159	33.2	579
450	422	328	105.6	440.5	51.2	197	159	38	627
500	480	361	131.8	491.6	64.2	197	159	41.2	696
600	562	459	152	592.5	70.2	276	216	50.7	821
700	624	520	163	695	82	300	254	63	895

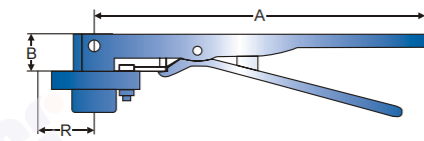

OVERALL DIMENSIONS & WEIGHT OF MANUAL ACTUATOR

SIZE (DN)	A	B	R	W.T (kg)
50-100	266.7	32	52	0.80
125-150	313	32	52	1
200-250	359	45	75.2	2.0
300	490	45	75.2	3.0

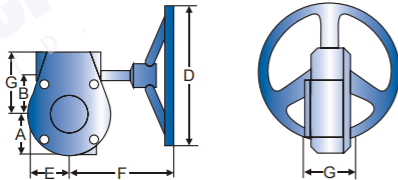

OVERALL DIMENSIONS & WEIGHT OF WORMGEAR ACTUATOR

SIZE (DN)	A	B	C	E	F	G	D	W.T (kg)
50-150	52	45	74	52	152.5	75	150	4.8
200-250	75	62.75	101	75	250	86	300	11.7
300-350	81	80	118	81	227	83	300	14

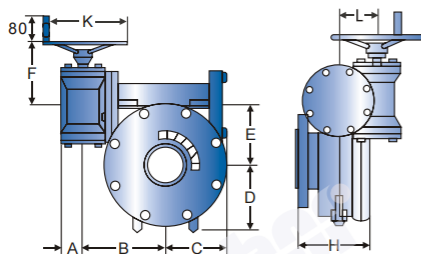

OVERALL DIMENSIONS & WEIGHT OF DOUBLE-STAGE WORMGEAR ACTUATOR

SIZE (DN)	A	B	C	D	E	F	H	L	K	W.T (kg)
400-450	42	160	125	130	90	200	105	60	300	40
500	42	185	160	150	110	200	120	60	380	55
600	42	185	160	170	125	225	120	60	380	60
700-800	50	228	185	190	155	155	125	78	380	90
900-1000	65	266	200	230	192	192	200	120	450	160

DIMENSIONAL DATA: API STANDARD BUTTERFLY VALVE, WAFER ENDS

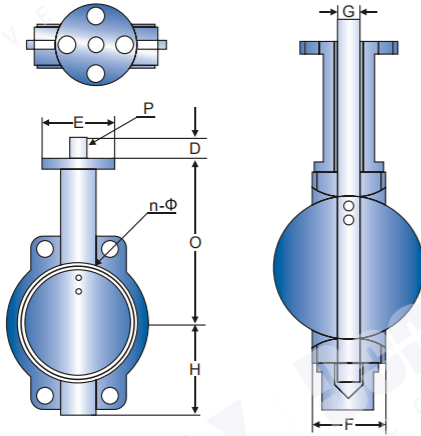

SIZE (DN)	A	C	D	E	F	G	H	Z	P	unit:mm
50	53	145	32	77	42	12.7	80	100	3	
65	65	160	32	77	45	12.7	89	120	3	
80	78.9	165	32	77	45	12.7	95	127	3	
100	104.5	185	32	92	52	15.9	114	156	5	
125	123.5	200	32	92	54	19.0	127	190	5	
150	156	210	32	92	56	19.0	139	212	5	
200	203	245	45	115	60	22.3	175	268	5	
250	251	285	45	115	66	28.6	203	325	8	
300	301.8	325	45	140	77	31.8	242	403	8	
350	333.3	368	45	140	77	31.8	267	436	8	
400	389.6	400	51.2	197	87	33.2	309	488	8	
450	440.51	422	51.2	197	106	38	328	540	9.5	
500	491.6	480	64.2	197	132	41.2	361	595	9.5	
600	592.5	562	70.2	276	152	50.7	459	695	13	
700	695	624	66	300	163	55	520			
800	794.7	672	66	300	188	55	591			
900	864.7	720	118	300	203	75	656			
1000	965	800	142	300	216	85	721			

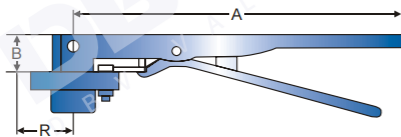

OVERALL DIMENSIONS & WEIGHT OF MANUAL ACTUATOR

SIZE(DN)	A	B	R	W.T (kg)	unit:mm
50-100	266.7	32	52	0.80	
125-150	313	32	52	1	
200-250	359	45	75.2	2.0	
300	490	45	75.2	3.0	

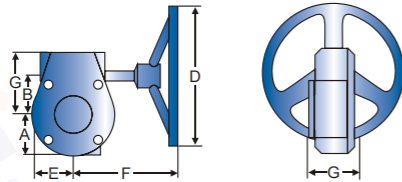

OVERALL DIMENSIONS & WEIGHT OF WORMGEAR ACTUATOR

SIZE (DN)	A	B	C	E	F	G	D	W.T (kg)	unit:mm
50-150	52	45	74	52	152.5	75	150	4.8	
200-250	75	62.75	101	75	250	86	300	11.7	
300-350	81	80	118	81	227	83	300	14	

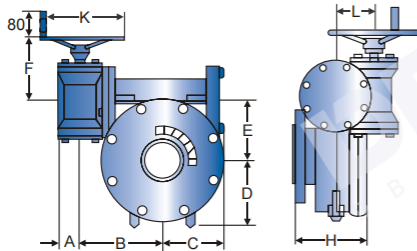

OVERALL DIMENSIONS & WEIGHT OF DOUBLE-STAGE WORMGEAR ACTUATOR

SIZE (DN)	A	B	C	D	E	F	H	L	K	W.T (kg)	unit:mm
400-450	42	160	125	130	90	200	105	60	300	40	
500	42	185	160	150	110	200	120	60	380	55	
600	42	185	160	170	125	225	120	60	380	60	
700-800	50	228	185	190	155	155	125	78	380	90	
900-1000	65	266	200	230	192	192	200	120	450	160	

DIMENSIONAL DATA: CORROSION RESISTANT BUTTERFLY VALVE, WAFER ENDS

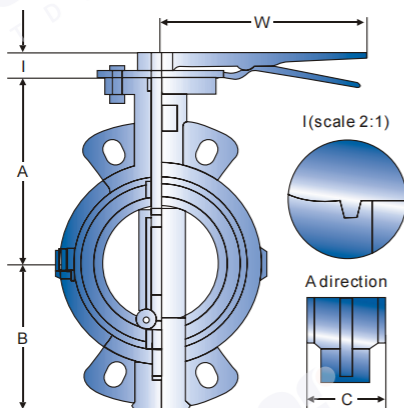

SIZE (in.)	A	B	L	C	W	ISO5211	Remark	unit:mm
2"	135	77	32	46	267	07	11X11	
2.5"	138	91	32	46	267	07	11X11	
3"	138	95	32	46	267	07	11X11	
4"	149	121	32	52	267	07	14X14	
5"	173	125	32	56	267	07	14X14	
6"	187	150	32	56	267	07	17X17	
8"	225	182	32	60	359	10	22X22	
10"	241	226	45	68	359	10	22X22	
12"	295	260	45	78	515	10		

CORROSION RESISTANT BUTTERFLY VALVE

This corrosion resistant butterfly valve is separated style, enclosed the valve with the PTFE liner ring, it can be fit for various corrosive and dangerous medium. Between the liner ring and valve is the back liner which was made of high-elasticity rubber, the liner ring disc adopts the double spherical surface sealing structure, used for guarantee the reliable closing and sealing performance ever some laceration emerges due to long-time using. With the ascendant design, it will be safety and no leaking out during long-term use.

Knife Gate valve

PRODUCT FEATURES

ROBUST AND COMPACT MOUNTING YOKE MADE OF STEEL

- Simple installation of Actuators or electric limit switches
- High functional reliability thanks to robust design

GLAND PACKING MADE OF PTFE IMPREGNATED FIBRES

- Reliable sealing to atmosphere
- Easy to replace without having to remove the valve from the piping
- Readjustable while in operation

SINGLE PIECE (UP TO DN500) OR TWO PIECE BODY WITH FULL BORE, MACHINED INSIDE

- Low pressure losses
- Perfect fit, reliable adjustment of U-shaped rod seal in the body

FLUSHING CORNERS IN THE BODY

- Seat is flushed clean when the valve closes

FLANGE CONNECTION VIA THREADED POCKET HOLES AND THROUGH BOLTS

- Universal use of the gate valve as wafer-type or dead-end valve at full operating pressure

NON-RISING STAINLESS STEEL STEM, NON-RISING HANDWHEEL

- Ideal in confined spaces

CAST IRON AND STEEL COMPONENTS EPOXY COATED AS AN OPTIONAL

- Gate valve highly protected against corrosion

STAINLESS STEEL VALVE DISC POLISHED ON BOTH SIDES, SEALED BY CONFINED U-SHAPED ROD SEAL FOR THE ENTIRE VALVE TRAVEL

- Excellent tightness in either flow direction
- No danger of deposits
- No fluttering of the disc
- Long service life

FLANGE SEALS INTEGRATED IN THE BODY AS A STANDARD (O-RING)

- No further seal required between flange and valve
- Installation-friendly as no external flange seals need to be fitted

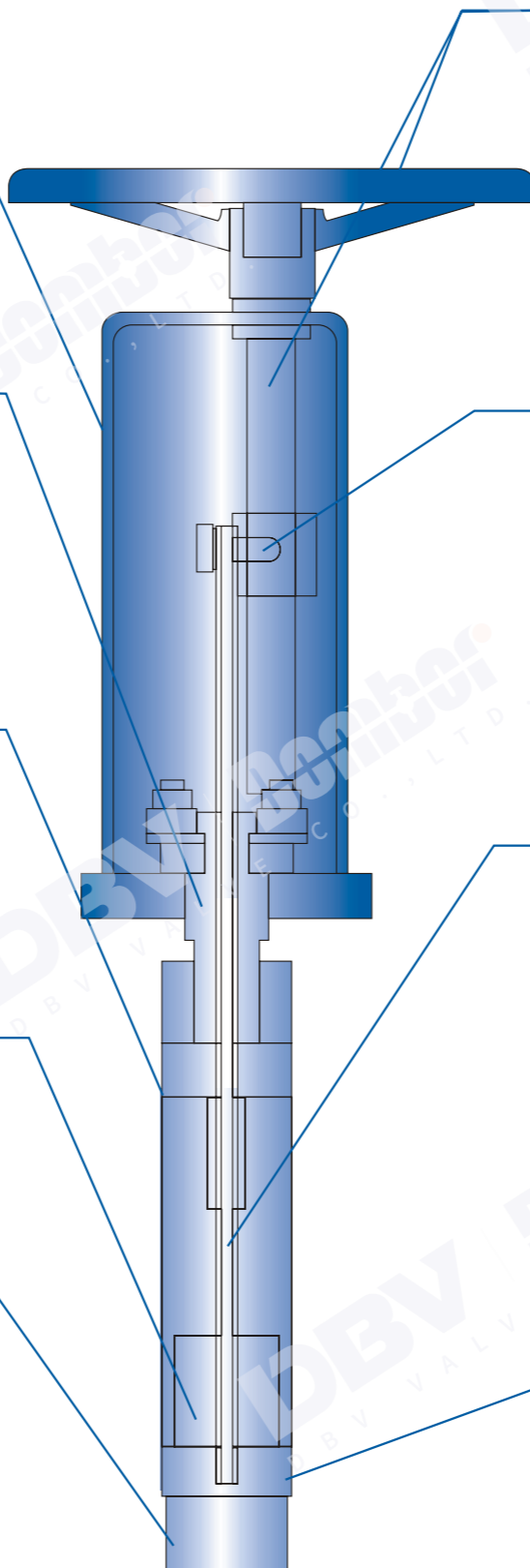

WIDE RANGE OF SIZES.

Available in sizes 2"~60". With ANSI 125/150 flange drilling or an option for DIN or other Standard.

BROAD LINE OF MATERIALS.

The solid cast stainless steel body is offered in alloys 304, 316, or 317L with either carbon steel or stainless steel topworks. Special alloys on request. Cast ductile iron bodies are offered with carbon steel topworks.

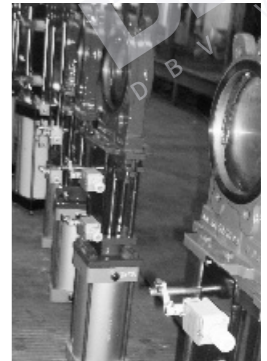
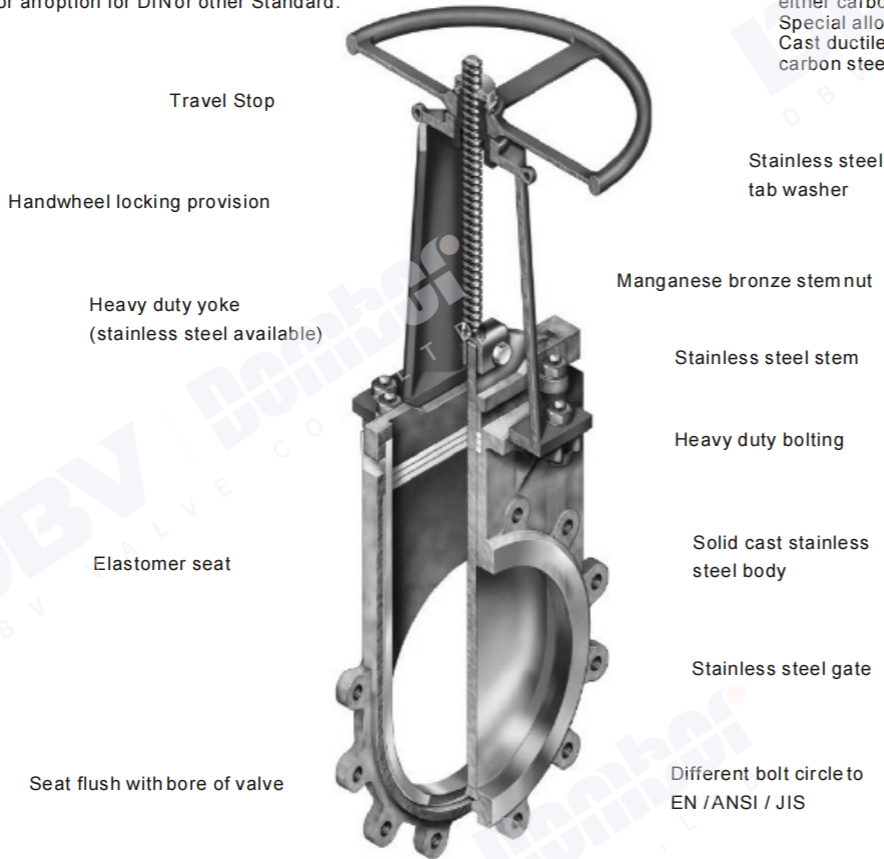

SEAL MATERIALS

- Stainless steel body
- White EPDM standard
(250°F to 280°F)
- White Viton available
(230°F to 350°F)
- Carbon steel body
- Black EPDM standard
(2150°F to 280°F)
- Black Viton available
(230°F to 350°F)



Accessories
Optional

ACTUATORS

- Pneumatic
- Electric
- Gear operators
- Chainwheels
- Floorstands

POSITIONERS

- Pneumatic
- Electro-pneumatic

SWITCHES

- Limit switches, yoke mounted
- Proximity switches, yoke mounted



ONE PIECE BODY: DN 50- DN 800

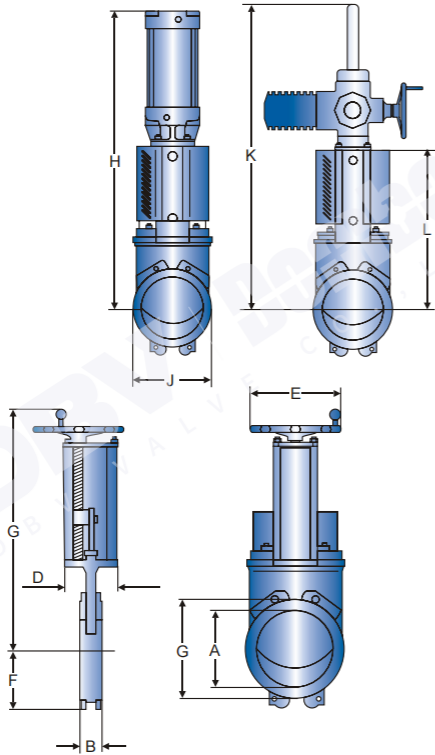

TWO PIECE BODY: DN 900- DN 1200

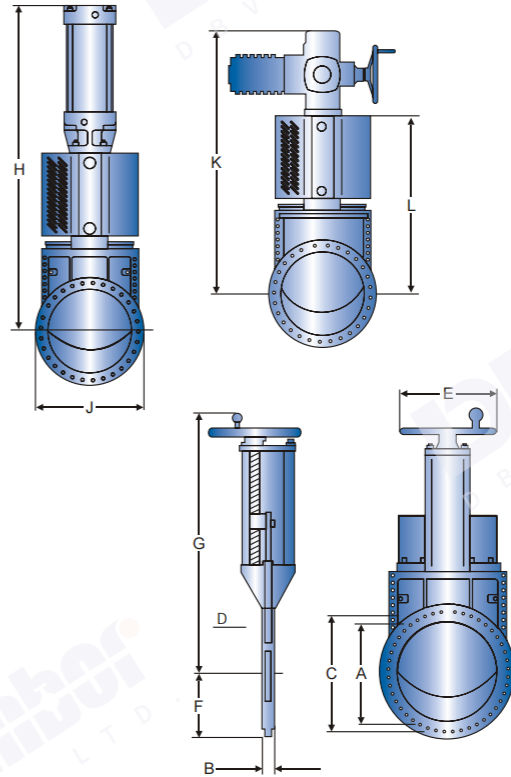

SIZE (DN)	A	B	C	D	E	F	G	H	J	K	L	W.T (kg)
50	52	41	91	80	200	56	360	475	116	620	230	7
65	64	41	107	80	200	65	380	495	130	650	250	7
80	79	51	124	80	200	88	405	545	135	690	275	8
100	103	51	154	80	200	102	453	593	155	765	323	10
125	128	56	179	80	250	116	495	685	178	830	365	13
150	153	60	204	80	250	130	550	740	205	910	420	15
200	202	60	267	145	315	160	694	1017	268	1115	555	31
250	250	69	320	145	315	192	779	1102	320	1250	640	40
300	302	78	374	145	315	230	879	1252	375	1400	740	55
350	332	78	419	175	400	240	993	1415	420	1550	820	90
400	380	89	479	175	400	245	1083	1555	490	1690	910	120
450	428	89	535	200	520	280	1180	1680	560	1820	990	180
500	470	114	580	250	520	313	1315	1865	625	2010	1127	245
600	560	114	680	260	635	370	1540	2355	740	2340	1352	340
700	665	118	800	310	635	390	1750	2513	865	2650	1565	460
750	710	118	860	310	635	490	1880	2900	930	2830	1635	700
800	760	118	900	310	635	490	1970	3030	985	2970	1780	540
900	855	118	1010	320	635	580	2220	3380	1160	3340	1985	900
1000	950	150	1110	320	635	640	2400	3670	1280	3630	2215	1500
1200	1200	150	1335	490	-	750	-	-	1500	4300	2860	-

Unit: mm

Knife Gate valve

FLANGE DRILLING

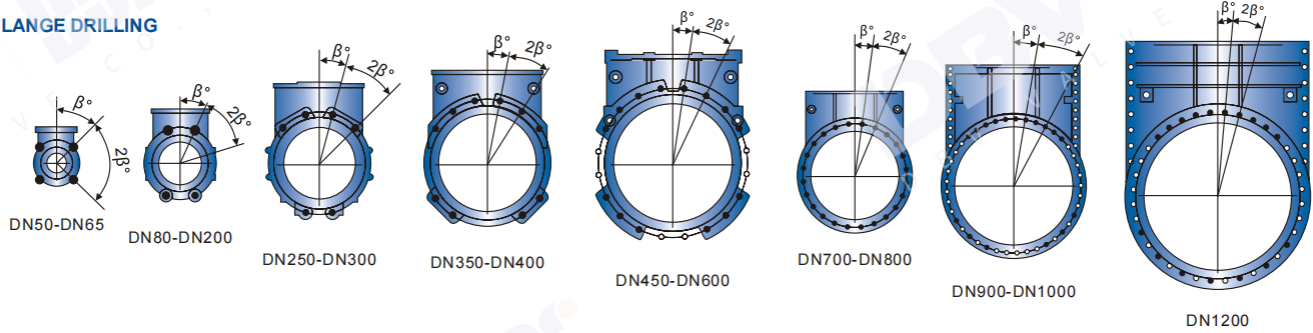

EN 1092 PN 10

SIZE(DN)	50	65	80	100	125	150	200	250	300	350	Unit: mm
Outside flange diameter (mm)	165	185	200	220	250	285	340	395	445	505	
Bolt circle diameter (mm)	125	145	160	180	210	240	295	350	400	460	
Number of throughgoing bolts(○)	-	-	4	4	4	4	4	6	6	6	
Number of tapped holes(●)	4	4	4	4	4	4	4	6	6	10	
Bolt size	M16	M16	M16	M16	M16	M20	M20	M20	M20	M20	
Size of throughgoing holes in flange	φ18	φ18	φ18	φ18	φ18	φ22	φ22	φ22	φ22	φ22	
β °	45	45	22.5	22.5	22.5	22.5	22.5	15	15	11.25	
Screw lengths ¹⁾	8 ²⁾	8 ²⁾	12	12	12	14	13	17	20	19	

EN 1092 PN 10

SIZE(DN)	400	450	500	600	700	800	900	1000	1200	Unit: mm
Outside flange diameter (mm)	565	615	670	780	895	1015	1115	1230	1455	
Bolt circle diameter (mm)	515	565	620	725	840	950	1050	1160	1380	
Number of throughgoing bolts(○)	6	6	6	6	10	10	12	12	10	
Number of tapped holes(●)	10	14	14	14	14	14	16	16	22	
Bolt size	M24	M24	M24	M27	M27	M30	M30	M33	M36	
Size of throughgoing holes in flange	φ26	φ26	φ26	φ30	φ30	φ33	φ33	φ36	φ39	
β °	11.25	9	9	9	7.5	7.5	6.43	6.43	5.63	
Screw lengths ¹⁾	22	22	27	27	25	27	27	30	32	

EN 1092 PN 16

SIZE(DN)	50	65	80	100	125	150	200	250	300	350	Unit: mm
Outside flange diameter (mm)	165	185	200	220	250	285	340	405	460	520	
Bolt circle diameter (mm)	125	145	160	180	210	240	295	355	410	470	
Number of throughgoing bolts(○)	-	-	4	4	4	4	6	6	6	6	
Number of tapped holes(●)	4	4	4	4	4	4	6	6	6	10	
Bolt size	M16	M16	M16	M16	M16	M20	M20	M24	M24	M24	
Size of throughgoing holes in flange	φ18	φ18	φ18	φ18	φ18	φ22	φ22	φ26	φ26	φ26	
β °	45	45	22.5	22.5	22.5	22.5	15	15	15	11.25	
Screw lengths ¹⁾	8 ²⁾	8 ²⁾	12	12	12	14	13	17	20	19	

EN 1092 PN 16

SIZE(DN)	400	450	500	600	700	800	900	1000	1200	Unit: mm
Outside flange diameter (mm)	580	640	715	840	910	1025	1125	1255	1485	
Bolt circle diameter (mm)	525	585	650	770	840	950	1050	1170	1390	
Number of throughgoing bolts(○)	6	6	6	6	10	10	12	12	10	
Number of tapped holes(●)	10	14	14	14	14	14	16	16	22	
Bolt size	M27	M27	M30	M33	M33	M36	M36	M39	M45	
Size of throughgoing holes in flange	φ30	φ30	φ33	φ36	φ36	φ39	φ39	φ42	φ48	
β °	11.25	9	9	9	7.5	7.5	6.43	6.43	5.63	
Screw lengths ¹⁾	22	22	27	27	25	27	27	30	32	

NOTE: 1) Add the valves with the thickness of Flanges and washers

2) The screws on the seat side has to be 3mm larger

○ through-going holes ● Tapped holes

FLANGE DRILLING

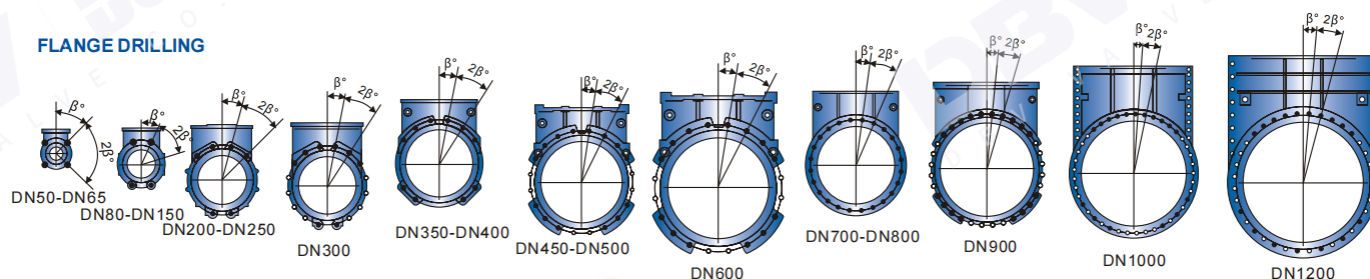

JIS B 2238 10K

SIZE(DN)	50	65	80	100	125	150	200	250	300	350	Unit: mm
Outside flange diameter (mm)	155	175	185	210	250	280	330	400	445	490	
Bolt circle diameter (mm)	120	140	150	175	210	240	290	355	400	445	
Number of throughgoing bolts (○)	-	-	4	4	4	4	6	6	8	6	
Number of tapped holes (●)	4	4	4	4	4	4	6	6	8	10	
Bolt size	M16	M16	M16	M16	M20	M20	M20	M22	M22	M22	
Size of throughgoing holes in flange	φ19	φ19	φ19	φ19	φ23	φ23	φ23	φ25	φ25	φ25	
β°	45	45	22.5	22.5	22.5	22.5	15	15	15	11.25	
Screw lengths ¹⁾	8 ²⁾	8 ²⁾	12	12	12	14	13	17	20	19	

JIS B 2238 10K

SIZE(DN)	400	450	500	600	700	750	800	900	1000	Unit: mm
Outside flange diameter (mm)	550	620	675	795	905	970	1020	1120	1235	
Bolt circle diameter (mm)	510	565	620	730	840	900	950	1050	1160	
Number of throughgoing bolts (○)	6	6	6	6	10	10	10	12	12	
Number of tapped holes (●)	10	14	14	18	14	14	18	16	16	
Bolt size	M24	M24	M24	M30	M30	M30	M30	M30	M36	
Size of throughgoing holes in flange	φ27	φ27	φ27	φ33	φ33	φ33	φ33	φ33	φ39	
β°	11.25	9	9	7.5	7.5	7.5	6.43	6.43	6.43	
Screw lengths ¹⁾	22	22	27	27	25	25	27	27	30	

ANSI B16.5 CLASS 150

SIZE(DN)	50	65	80	100	125	150	200	250	300	350	Unit: mm
Outside flange diameter (mm)	152.4	177.8	190.5	228.6	254	297.4	342.9	406.4	482.6	533	
Bolt circle diameter (mm)	120.7	139.7	152.4	190.5	215.9	241.3	298.5	362	431.8	476.3	
Number of throughgoing bolts (○)	-	-	2	4	4	4	4	6	6	6	
Number of tapped holes (●)	4	4	2	4	4	4	4	6	6	6	
Bolt size	5/8-11	5/8-11	5/8-11	5/8-11	3/4-10	3/4-10	3/4-10	7/8-9	7/8-9	1-8	
Size of throughgoing holes in flange	φ18	φ18	φ18	φ18	φ22	φ22	φ22	φ26	φ26	φ30	
β°	45	45	22.5	22.5	22.5	22.5	22.5	15	15	15	
Screw lengths ¹⁾	8 ²⁾	8 ²⁾	12	12	12	14	13	17	20	19	

ANSI B16.5 CLASS 150

SIZE(DN)	400	450	500	600	700	750	800	900	1000	1200	Unit: mm
Outside flange diameter (mm)	597	635	699	813	927.1	984.3	1060	1168.4	1289.1	1511	
Bolt circle diameter (mm)	539.8	577.9	635	749.3	863.6	914.4	977.9	1085.9	1200.1	1422.4	
Number of throughgoing bolts (○)	6	6	6	6	10	10	10	12	18	28	
Number of tapped holes (●)	10	10	14	14	18	18	18	20	18	16	
Bolt size	1-8	1-1/8-7	1-1/8-7	1-1/4-7	1-1/4-7	1-1/4-7	1-1/2-6	1-1/2-6	1-1/2-6	1-1/2-6	
Size of throughgoing holes in flange	φ30	φ33	φ33	φ36	φ36	φ36	φ42	φ42	φ42	φ42	
β°	11.25	11.25	9	9	6.43	6.43	6.43	5.63	5	4.01	
Screw lengths ¹⁾	22	22	27	27	25	25	27	27	33	32	

NOTE: 1) Add the valves with the thickness of Flanges and washers

2) The screws on the seat side has to be 3mm larger

○ through-going holes ● Tapped holes

Knife Gate valve

MAIN PARTS

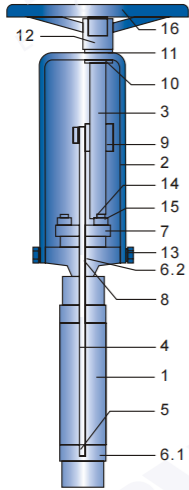

TEST AND OPERATING PRESSURES

Nominal pressure	Nominal diameter	Shell / body pressure test With water	Leak test With water	Permissible operating pressures
PN	DN			
10	50-250	15	11	10
6	300-400	9	6.6	6
5	450	7.5	5.5	5
4	500-600	6	4.4	4
2	700-1200	3	2.2	2

- 1) DIN EN 12266-1
 2) DIN EN 12266-1 (DN 50-600: leakage rate A, DN 700-1200: leakage rate B)
 3) at fluid temperature up to 120 °C

MATERIALS

Part No	Designation	Materials		Notes
1	Body	EN-GJL-250	JL 1040	Single piece up to DN 500 two piece from DN 600
2	Yoke	Steel	1.4305/ AISI 303	
3	Stem	Stainless steel.	1.4571/ AISI 316Ti	Non-rising
4	Valve disc	Stainless steel.	1.4301/ AISI 304	DN 50-400 DN 450 and largerR
5	U-shaped rod seal	Steel cored EPDM		
6.1	O-ring	EPDM		Integrated flange seal
6.2	O-ring	EPDM		
7	Gland flange	EN-GJS-400-15	JS 1030	
8	Gland flange	PTFE Impregnated synthetic fibres		
9	Stem nut	Brass		
10	Guiding bush	Brass		
11	Anti-friction disc	Nylon		
12	Spring-type straight pin	Steel	DIN 7346	
13	Hex. Head bolt	A2		
14	Bolts	A2		
15	Hexagon nut	A2		
16	Handwheel	Steel	JL 1040	DN 50-300 From DN 350

VARIANTS

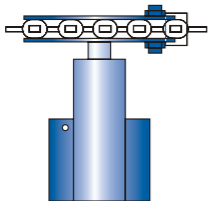

Chain wheel (non-rising stem)

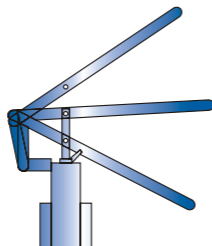

Quick-action lever

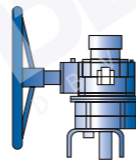

Gearbox (non-rising stem)

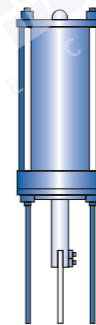

Pneumatic actuator (double-acting)

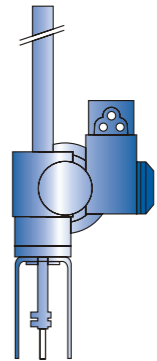

Electric actuator (rising stem)

DIMENSIONS

Face-to-face length
EN 558-1/20 (was DIN 3202 K1)
up to DN 500
from DN 600 see table

FLANGE:

Standard-mating dimensions to
EN 1092-2 PN 10
Further flange connections on request

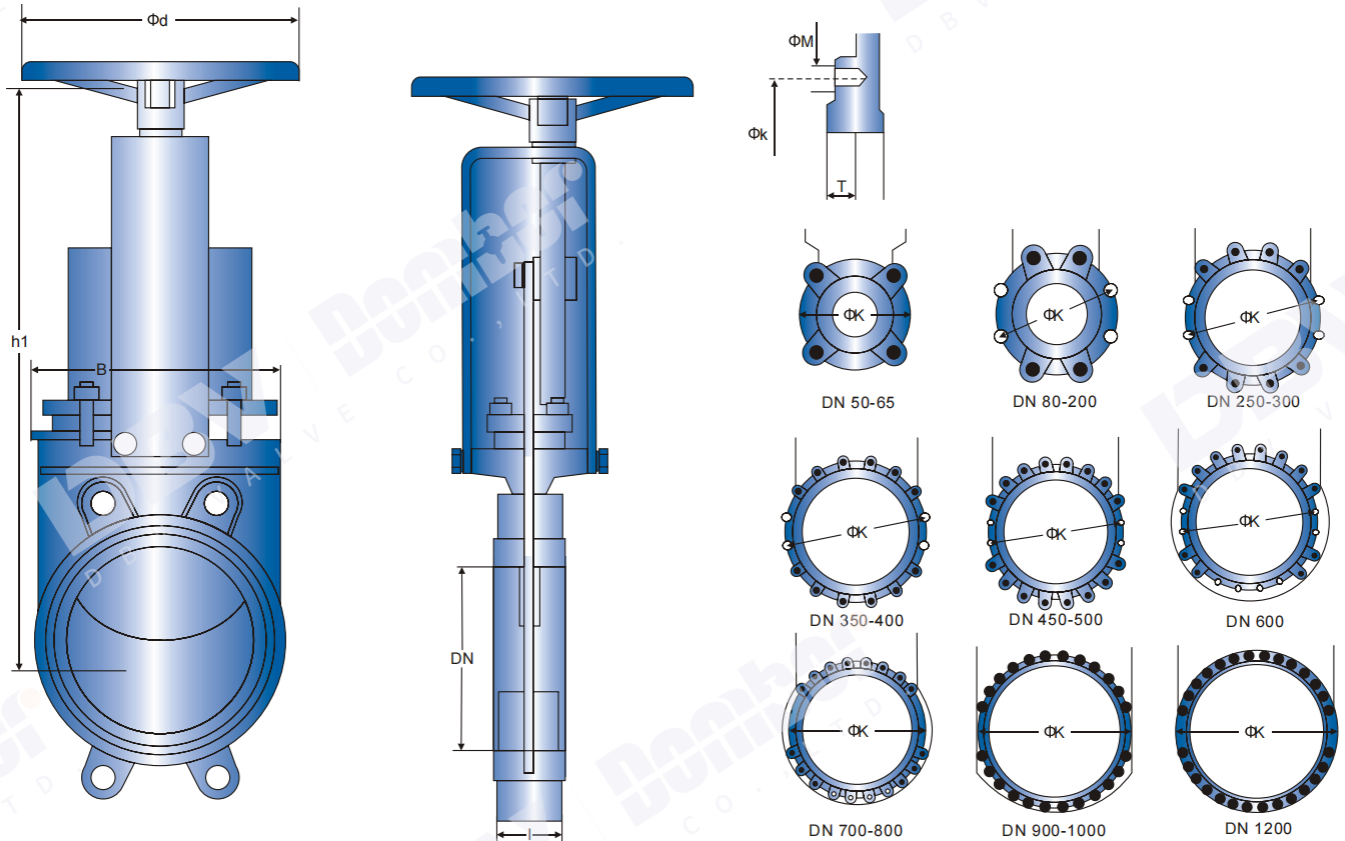

DIMENSION

Nom. Pressure	Nom. Diameter	Face-to-face length	Overall height when open	Body width	Hand wheel	Bolt circle	Number of bolt holes	Bolt size	Pocket hole-depth	Number of threaded packet holes	Number of through-holes 1)	Number of tapped holes	W.T (kg)
PN	DN	l	h1	B	φd	φk	z	φM	T	n1	n2	n3	Unit: mm
10	50	43	299	113	225	125	4	M16	10	4	0	0	8
	65	46	325	128	225	145	4	M16	10	4	0	0	9
	80	46	350	143	225	160	8	M16	12	4	4	0	10
	100	52	391	162	225	180	8	M16	12	4	4	0	12
	125	56	425	181	225	210	8	M16	14	4	4	0	15
	150	56	471	209	225	240	8	M20	14	4	4	0	17
6	200	60	581	263	300	295	8	M20	14	4	4	0	30
	250	68	681	315	300	350	12	M20	18	8	4	0	42
	300	76	771	370	300	400	12	M20	21	8	4	0	60
5	350	78	908	420	410	460	16	M20	21	6	4	6	90
	400	102	993	478	410	515	16	M24	28	8	4	4	150
	450	114	1180	530	550	565	20	M24	30	12	4	4	185
4	500	127	1195	584	550	620	20	M24	40	12	4	4	224
	600	100	1405	762	550	725	20	M27	26	12	8	0	230
2	700	110	1736	890	800	840	24	M27	20	16	8	0	380
	800	110	1923	1012	800	950	24	M30	20	16	8	0	550
	900	110	2047	1112	800	1050	28	M30	20	20	8	0	680
	1000	110	2487	1240	800	1160	28	M33	20	20	8	0	800

1) bolts passing along the side of the body

Gate Valve

HIGH CORROSION RESISTANCE AND A PERFECT FINISH

UPPER O-RING SEALS
can be replaced while the valve is fully open and under pressure.

LOWER O-RING SEAL
seals lubrication chamber.

HIGH-STRENGTH BRONZE STEM AND WEDGE NUT
resist corrosion and abuse.

DUCTILE IRON CONSTRUCTION
Greater strength, durability, and light weight.

SMOOTH WATERWAY CONSTRUCTION
Oversize waterway. No recesses to trap debris or obstruct flow. Reduces pumping costs.

DUCTILE IRON OPERATING NUT
provides strength and durability.

THRUST WASHERS
minimize operating torque.

FUSION-BONDED-EPOXY COATING INSIDE AND OUTSIDE
ensures maximum corrosion resistance for long service life.

EPDM RUBBER-ENCAPSULATED DUCTILE IRON WEDGE
ensures drop tight seal every time with low stem torque.

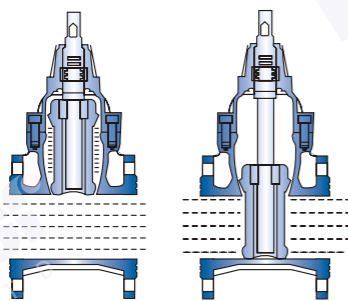
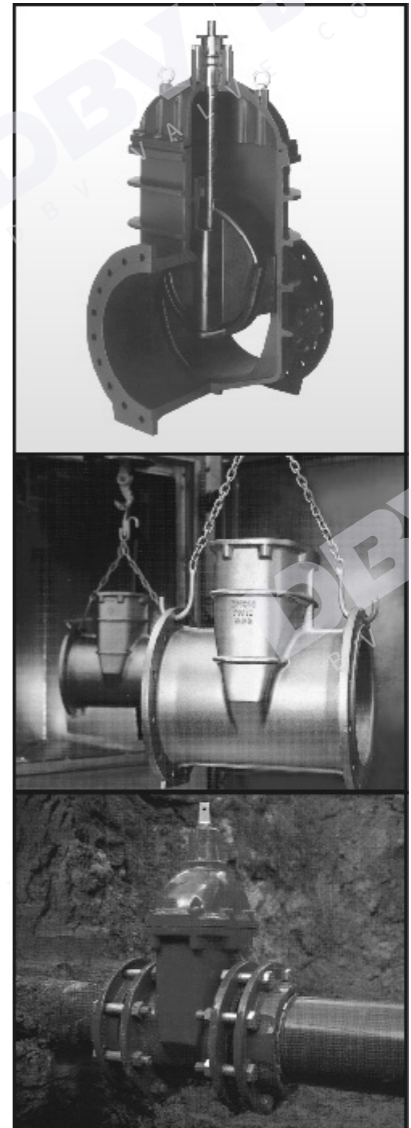

Figure 1 Resilient Seated Gate Valves (the straight bore structure)

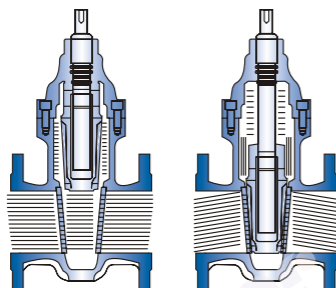

Figure 2 Metal Seated Gate Valves (the nonstraight bore structure)

A PERFECT SOLUTION FOR YOUR APPLICATIONS



Cast Iron Flanged Gate Valves are very popular used in the area of water, waste water and sewage. DBV valves design is based on the different customers' requirements, aims quality, performance and satisfaction as our core-stone.

STANDARD MATERIAL CONSTRUCTION

PARTS	MATERIAL	ASTM	DIN	BS
Body	Cast Iron	A126 Gr.B	1691 GG-25	1452 Gr.200
	Ductile Iron	A536 Gr. 65-45-12	1693 GGG-50	2789 Gr. 500/7
Bonnet	Cast Iron	A126 Gr.B	1691 GG-25	1452 Gr.200
	Ductile Iron	A536 Gr. 65-45-12	1693 GGG-50	2789 Gr. 500/7
Disc	Ductile Iron	A536 Gr. 65-45-12	1693 GGG-50	2789 Gr. 500/7
Stem	Stainless Steel	A276 Type 410	17440 1.4006	970 Gr. 410S21
		A276 Type 431	17440 1.4057	970 Gr. 431S29
		A276 Type 316	17440 1.4401	970 Gr. 316S16

Other Materials Available upon Request

AWWAC509 & C515 RESILIENT SEATED GATE VALVE NRS FL X FL

- Cast or Ductile Iron Body, Bonnet, Wedge and Gland,
- Resilient Wedge, NonRising Stem, Bolted Bonnet,
- Fusion Bonded Epoxy Coating to AWWAC550,
- Flanged Ends to ANSI B16.1 CL150 ANSI B16.2 CL250
- Design and Manufacture to AWWA C509, C515 & C550

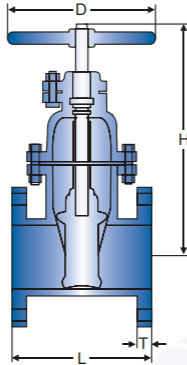

Face to Face	AWWA/ANSI
End Flange	ANSI B16.1, CL150 ANSI B16.2 CL250
Class	B16.1, CL150B, B16.2, CL250B

SIZE (in.)	L	H	D	T	W.T (lbs)	Unit: inch
2	7	9-7/8	7-1/4	5/8	49	
2-1/2	7-1/2	11	7-1/4	3/4	51	
3	8	13-1/2	10	3/4	65	
4	9	15-1/2	10	1	99	
5	10	16-1/2	12	1	143	
6	10-1/2	18-1/4	12	1	154	
8	11-1/2	22-1/2	14	1-1/8	229	
10	13	25-1/2	17-1/2	1-1/4	372	
12	14	30-1/2	17-1/2	1-1/4	588	
14	15	34	21	1-3/8	756	
16	16	40-7/8	21	1-1/2	1,212	

AWWAC509 & C515 RESILIENT SEATED GATE VALVE NRS MJ X MJ

- Cast or Ductile Iron Body, Bonnet, Wedge and Gland,
- Resilient Wedge, NonRising Stem, Bolted Bonnet,
- Fusion Bonded Epoxy Coating to AWWAC550,
- Design and Manufacture to AWWA C509, C515 & C550

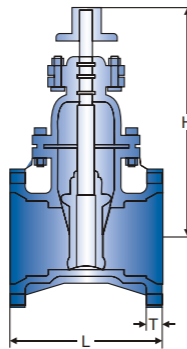

Face to Face	AWWA/ANSI
End Flange	ANSI B16.1, CL150 ANSI B16.2, CL250
M.J Ends	AWWA/ANSI
Ratings	B16.2 CL250B

SIZE (in.)	L	H	T	W.T (lbs)	Unit: inch
2	8	9-7/8	1	45	
2-1/2	8-1/2	11	1	52	
3	9	13-1/2	1	67	
4	10	15-1/2	1	94	
5	11	16-1/2	1	131	
6	11-1/2	18-1/4	1	140	
8	12-1/2	22-1/2	1	210	
10	14-3/4	25-1/2	1	356	
12	14-7/8	30-1/2	1-1/4	540	
14	17	34-1/2	1-1/4	716	
16	17	40-1/4	1-1/4	1,168	

AWWAC509 & C515 RESILIENT SEATED GATE VALVE NRS FL X MJ

- Cast or Ductile Iron Body, Bonnet, Wedge and Gland,
- Resilient Wedge, NonRising Stem, Bolted Bonnet,
- Fusion Bonded Epoxy Coating to AWWA C550,
- Flanged Ends to ANSI B16.1 CL150, MJ Ends to ANSI/AWWA
- Design and Manufacture to AWWAC509, C515 & C550

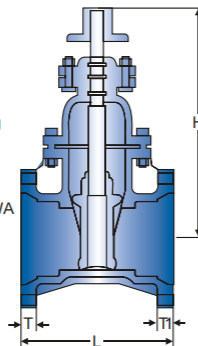

Face to Face	AWWA/ANSI
End Flange	ANSI B16.1, CL150 ANSI B16.2, CL250
M.J Ends	AWWA/ANSI
Class	B16.1, CL150B, B16.2, CL250B

SIZE (in.)	L	H	T	T1	W.T (lbs)	Unit: inch
2	8-1/2	9-7/8	5/8	1	44	
2-1/2	8	11	3/4	1	46	
3	8-3/4	13-1/2	3/4	1	48	
4	9-1/2	15-1/2	1	1	60	
5	10-1/2	16-1/2	1	1	99	
6	11-1/8	18-1/4	1	1	101	
8	12	22-1/2	1-1/8	1	160	
10	13-7/8	25-1/2	1-1/4	1	240	
12	14-1/2	30-1/2	1-1/4	1-1/4	370	
14	17-1/2	34	1-3/8	1-1/4	672	
16	18	40-1/4	1-1/2	1-1/4	830	

Gate Valve

AWWA C509 & C515 RESILIENT SEATED GATE VALVE NRS FL X PO

- Cast or Ductile Iron Body, Bonnet, Wedge and Gland,
- Resilient Wedge, NonRising Stem, Bolted Bonnet,
- Fusion Bonded Epoxy Coating to AWWA C550,
- Flanged Ends to ANSI B16.1 CL150, Push on ends for use with Ductile Iron Pipe and C900 PVC Pipe
- Design and Manufacture to AWWAC509, C515 & C550

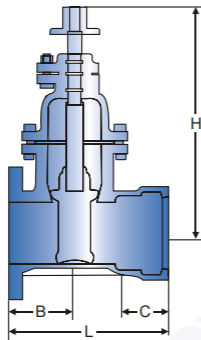

Face to Face	AWWA/ANSI
End Flange	ANSI B16.1, CL150
Push On Ends	C900 PVC Pipe
Ratings	B16.1, CL150B

SIZE (in.)	B	C	D	L	H	T	W.T (lbs)
4	4-1/2	3-1/2	10	11	15-1/2	1	74
6	5-1/4	4	12	12-2/3	18-1/4	1	118
8	5-3/4	4-1/2	14	14-2/4	22-1/2	1	199
10	6-1/2	4-1/2	17-1/2	15-3/4	25-1/2	1	296
12	7	5	17-1/2	16-1/3	30-1/2	1-1/4	432

Larger Sizes Available Upon Request

AWWAC509 & C515 RESILIENT SEATED GATE VALVE NRS PO X PO

- Cast or Ductile Iron Body, Bonnet, Wedge and Gland,
- Resilient Wedge, NonRising Stem, Bolted Bonnet,
- Fusion Bonded Epoxy Coating to AWWAC550,
- Push on ends for use with Ductile Iron Pipe and C900 PVC Pipe
- Design and Manufacture to AWWAC509, C515 & C550

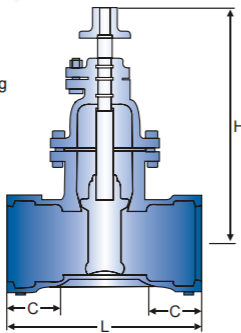

Face to Face	AWWA/ANSI
End Flange	ANSI B16.1, CL150
Push On Ends	C900 PVC Pipe
Ratings	B16.1, CL150B

SIZE (in.)	C	D	L	H	W.T (lbs)
4	3-1/2	10	12-3/4	15-1/2	64
6	4	12	14-3/4	18-1/4	110
8	4-1/2	14	17-3/4	22-1/2	190
10	4-1/2	17-1/2	18-1/2	25-1/2	301
12	5	17-1/2	16-2/3	30-1/2	447

Larger Sizes Available Upon Request

AWWAC509 & C515 RESILIENT SEATED GATE VALVE OS&Y FL X FL

- Cast or Ductile Iron Body, Bonnet, Wedge and Gland,
- Resilient Wedge, Rising Stem, Bolted Bonnet,
- Fusion Bonded Epoxy Coating to AWWAC550,
- Flanged Ends to ANSI B16.1 CL150
- Design and Manufacture to AWWAC509, C515 & C550

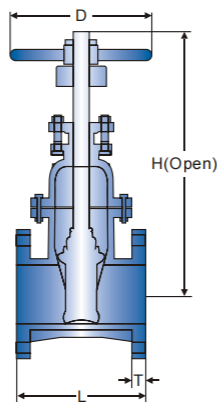

Face to Face	AWWA/ANSI
End Flange	ANSI B16.1, CL150 ANSI B16.2, CL250
M.J Ends	AWWA/ANSI
Class	B16.1, CL150B, B16.2, CL250B

SIZE (in.)	L	H	D	T	W.T (lbs)
2	7	15-3/4	7	5/8	51
2-1/2	7-1/2	16	7	3/4	59
3	8	19-1/8	7-1/2	3/4	68
4	9	24	10	1	105
5	10	27-1/2	12	1	145
6	10-1/2	31-1/8	12	1	172
8	11-1/2	39-1/2	14	1-1/8	243
10	13	46-3/4	16	1-1/4	430
12	14	56	18	1-1/4	685
14	15	64	20	1-3/8	1,058
16	16	75	22	1-1/2	1,720

AWWAC500 METAL SEATED GATE VALVE NRS FL X FL

- Cast or Ductile Iron Body, Bonnet, Wedge and Gland,
- Solid Wedge, NonRising Stem, Bolted Bonnet,
- Fusion Bonded Epoxy Coating to AWWAC550,
- Flanged Ends to ANSI B16.1 CL150, ANSI B16.2 CL250
- Design and Manufacture to AWWA C500

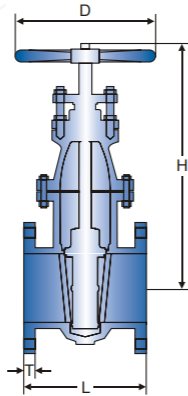

Face to Face	AWWA/ANSI
End Flange	ANSI B16.1, CL150 ANSI B16.2, CL250
Class	B16.1, CL150B, B16.2, CL250B

SIZE (in.)	L	H	D	T 150	T 250	W.T (lbs)	Unit: inch
2	7	12-1/2	7	5/8	7/8	47	
3	8	13-1/2	7-1/2	3/4	1-1/8	60	
4	9	16-1/2	10	1	1-1/4	97	
6	10-1/2	21-1/2	12	1	1-1/2	158	
8	11-1/2	26-1/2	14	1-1/8	1-5/8	229	
10	13	30	16	1-1/4	1-7/8	388	
12	14	33	18	1-1/4	2	611	
14	15	40	20	1-3/8	2-1/8	749	
16	16	44	22	1-1/2	2-1/4	1,148	

AWWAC500 METAL SEATED GATE VALVE OS&Y FL X FL

- Cast or Ductile Iron Body, Bonnet, Wedge and Gland,
- Solid Wedge, Rising Stem, Bolted Bonnet,
- Fusion Bonded Epoxy Coating to AWWAC550,
- Flanged Ends to ANSI B16.1 CL150, ANSI B16.2 CL250
- Design and Manufacture to AWWA C500

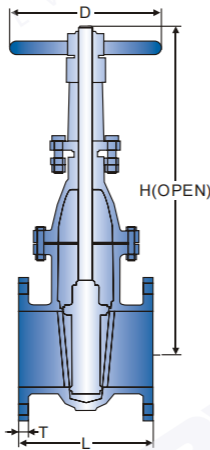

Face to Face	AWWA/ANSI
End Flange	ANSI B16.1, CL150 ANSI B16.2, CL250
M.J Ends	AWWA/ANSI
Ratings	B16.2 CL250B

SIZE (in.)	L	H	D	T 150	T 250	W.T (lbs)	Unit: inch
2	7	16	7	5/8	7/8	47	
3	8	19	7-1/2	3/4	1-1/8	60	
4	9	25	10	1	1-1/4	97	
6	10-1/2	33	12	1	1-1/2	161	
8	11-1/2	43-1/2	14	1-1/8	1-5/8	229	
10	13	48	16	1-1/4	1-7/8	388	
12	14	54	18	1-1/4	2	611	
14	15	63	20	1-3/8	2-1/8	749	
16	16	75	22	1-1/2	2-1/4	1,148	

DIN3202 F4 RESILIENT SEATED GATE VALVE OS&Y

- Cast or Ductile Iron Body, Bonnet, Wedge and Gland,
- Resilient Wedge, Rising Stem, Bolted Bonnet,
- Fusion Bonded Epoxy Internally and Externally
- Flanged Ends to DIN 2532/2533, BSEN1092
- Design and Manufacture to DIN 3352

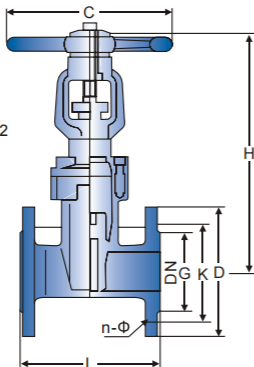

Face to Face	DIN3202 F4, EN558 Series 14
End Flange	DIN2532/2533, BS EN 1092
Class	PN10/16

SIZE (DN)	L	D		K		G		B	H	C	n-φ d		WT (kg)
		PN10	PN16	PN10	PN16	PN10	PN16				PN10	PN16	
50	150	165	165	125	125	102	102	20	327	178	4-φ18	4-φ18	16
65	170	185	185	145	145	122	122	20	368	178	4-φ18	4-φ18	20
80	180	200	200	160	160	138	138	20	405	203	4-φ18	8-φ18	24
100	190	220	220	180	180	158	158	22	452	254	8-φ18	8-φ18	30
125	200	250	250	210	210	188	188	22	610	254	8-φ18	8-φ18	48
150	210	285	285	240	240	212	212	22	615	305	8-φ23	8-φ23	51
200	230	340	340	295	295	268	268	24	775	356	8-φ23	12-φ23	87
250	250	395	405	350	355	320	320	26	900	405	12-φ23	12-φ27	124
300	270	445	460	400	410	370	378	28	1008	457	12-φ23	12-φ27	170

Gate Valve

DIN3202 F4 RESILIENT SEATED GATE VALVE NRS

- Cast or Ductile Iron Body, Bonnet, Wedge and Gland,
- Resilient Wedge, Non Rising Stem, Bolted Bonnet,
- Fusion Bonded Epoxy Internally and Externally
- Flanged Ends to DIN2532/2533, BS EN1092
- Design and Manufacture to DIN 3352

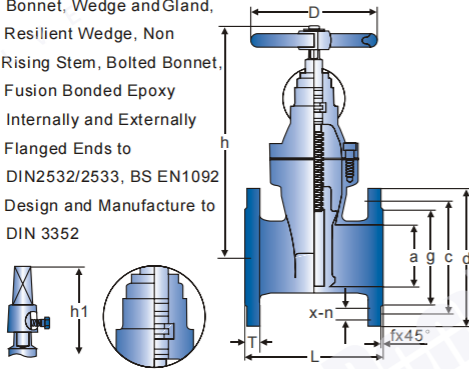

Face to Face	DIN3202 F4, EN558 Series 14
End Flange	DIN2532/2533, BS EN1092
Class	PN10/16

SIZE (DN)	L	h	D	h1	a	d	c	x-n	T	g	f	W.T (kg) Unit: mm	
40	140	285	180	355	40	150	110	4-φ19	19	84	3	12	
50	150	290	180	360	50	165	125	4-φ19	19	99	3	14	
65	170	295	180	365	65	185	145	4-φ19	19	118	3	15	
80	180	340	205	410	80	200	160	8-φ19*	19	132	3	20	
100	190	370	240	440	100	220	180	8-φ19	19	156	3	25	
125	200	445	240	515	125	250	210	8-φ19	19	184	3	36	
150	210	465	280	535	150	285	240	8-φ23	19	211	3	45	
200	230	580	320	650	200	340	295	8-φ23/12-φ23	20	266	3	72	
250	250	665	360	735	250	395/405	350/355	12-φ23/12-φ28	22	319	3	102	
300	270	785	450	855	300	445/460	400/410	12-φ23/12-φ28	24.5	370	4	160	
350	290	970	500	1040	350	505/520	460/470	16-φ23/16-φ28	26.5	429	4	288	
400	310	1020	560	1120	400	565/580	515/525	16-φ28/16-φ31	28	480	4	387	
450	330	1120	560	1200	450	615/640	565/585	20-φ28/20-φ31	30	530	548	4	490
500	350	1220	650	1300	500	670/715	620/650	20-φ28/20-φ34	31.5	582	609	4	620
600	390	1370	650	1470	600	780/840	725/770	20-φ31/20-φ37	36	682	720	5	760

* PN10: DIN 2532 4-f19 , BS EN1092 8-f19

DIN3202 F5 RESILIENT SEATED GATE VALVE NRS

- Cast or Ductile Iron Body, Bonnet, Wedge and Gland,
- Resilient Wedge, Non Rising Stem, Bolted Bonnet,
- Fusion Bonded Epoxy Internally and Externally
- Flanged Ends to DIN 3202 F5 (EN558-1 SERIE 15)
- Design and Manufacture to DIN 3352

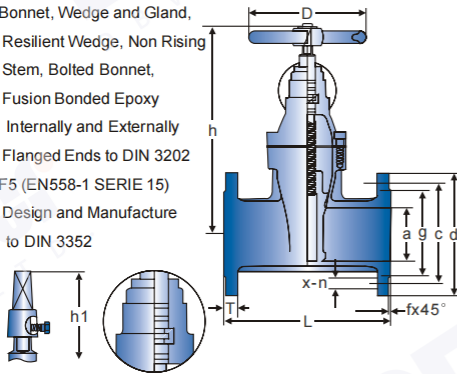

Face to Face	DIN3202 F5, EN558 Series 15
End Flange	DIN2532/2533, BS EN1092
Class	PN10/16

SIZE (DN)	L	h	D	h1	a	d	c	x-n	T	g	f	W.T (kg) Unit: mm	
40	240	285	180	355	40	150	110	4-φ19	19	84	3	13	
50	250	290	180	360	50	165	125	4-φ19	19	99	3	15	
65	270	295	180	365	65	185	145	4-φ19	19	118	3	16	
80	280	340	205	410	80	200	160	8-φ19*	19	132	3	23	
100	300	370	240	440	100	220	180	8-φ19	19	156	3	29	
125	325	445	240	515	125	250	210	8-φ19	19	184	3	44	
150	350	465	280	535	150	285	240	8-φ23	19	211	3	54	
200	400	580	320	650	200	340	295	8-φ23 12-φ23	20	266	3	95	
250	450	665	360	735	250	395 405	350 355	12-φ23 12-φ28	22	319	3	153	
300	500	785	450	855	300	445 460	400 410	12-φ23 12-φ28	24.5	370	4	241	
350	550	970	500	1040	350	505 520	460 470	16-φ23 16-φ28	26.5	429	4	255	
400	600	1020	560	1120	400	565 580	515 525	16-φ28 16-φ31	28	480	4	475	
450	650	1120	560	1200	450	615 640	565 585	20-φ28 20-φ31	30	530	548	4	590
500	700	1220	650	1300	500	670 715	620 650	20-φ28 20-φ34	31.5	582	609	4	730
600	800	1370	650	1470	600	780 840	725 770	20-φ31 20-φ37	36	682	720	5	890

* PN10: DIN 2532 4-φ19 , BS EN1092 8-φ19

EN RESILIENT SEATED GATE VALVE NRS POX PO

- Cast or Ductile Iron Body, Bonnet, Wedge and Gland,
- Resilient Wedge, Non Rising Stem, Bolted Bonnet,
- Fusion Bonded Epoxy Internally and Externally
- Push on ends for use with Ductile Iron Pipe and PVC Pipe
- Design and Manufacture to DIN3352

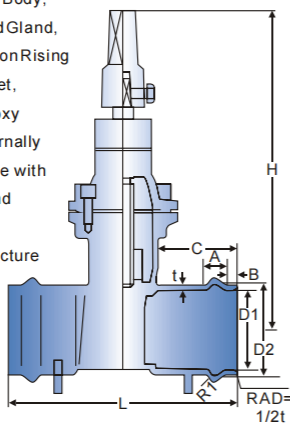

Face to Face	SABS664
Push On Ends	Suitable for D.I. & PVC Pipe
Class	PN10/16

SIZE (DN)	D1	D2	D3	R1	R2	R3	A	B	C	t	L	H
50/63	63.8	80.2	55	5.0	8	16	32	15	90	6	335	250
65/75	75.8	94.1	65	5.5	9	18	35.7	15	110	6	335	275
80/90	90.9	110.9	78	6.0	10	19	39	17	110	6	335	306
100/110	111.0	132.7	98	6.5	12	21	43.1	18	110	7	355	337
150/160	161.2	186.2	140	7.5	17	27	52	22	120	7	405	429
200/200	201.4	227.8	178	8.0	18	30	56	24	135	7.5	450	522
225/225	227	255	200	8.5	18.5	30.5	58	26	135	8	450	522
250/250	251.7	282.8	228	9.0	23	37	66.5	27	150	8.5	500	599
280/280	282	312	250	10	20	65	72	27	150	8.5	500	599
300/315	317.0	351.5	293	10.5	24	55.7	77.5	30	170	8.5	550	689

BS5163 RESILIENT SEATED GATE VALVE NRS

- Cast or Ductile Iron Body, Bonnet, Wedge and Gland,
- Resilient Wedge, Non Rising Stem, Bolted Bonnet,
- Fusion Bonded Epoxy Internally and Externally
- Flanged Ends to BS4502, EN1092
- Design and Manufacture to BS5163

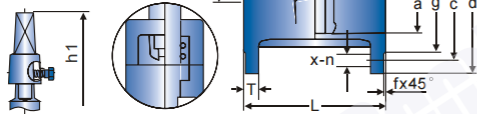

Face to Face	BS5163, ISO5752 Series 3
End Flange	BS4504, BS EN1092
Class	PN10/16

SIZE (DN)	L	h	D	h1	a	d	c	x-n	T	g	f	W.T (kg)	
40	165	275	180	345	40	150	110	4-φ19	19	84	3	12	
50	178	280	180	350	50	165	125	4-φ19	19	99	3	13	
65	190	300	180	370	65	185	145	4-φ19	19	118	3	15	
80	203	335	205	405	80	200	160	8-φ19	19	132	3	22	
100	229	341	240	411	100	220	180	8-φ19	19	156	3	26	
125	254	430	240	500	125	250	210	8-φ19	19	184	3	35	
150	267	485	280	555	150	285	240	8-φ23	19	211	3	50	
200	292	580	320	650	200	340	295	8-φ23 12-φ23	20	266	3	70	
250	330	680	360	750	250	395	405	350 355	12-φ23 12-φ28	22	319	3	125
300	356	785	450	855	300	445	460	400 410	12-φ23 12-φ28	24.5	370	4	174
350	381	880	500	950	350	505	520	460 470	16-φ23 16-φ28	26.5	429	4	320
400	406	990	560	1060	400	565	580	515 525	16-φ28 16-φ31	28	480	4	430
450	432	1120	560	1200	450	615	640	565 585	20-φ28 20-φ31	30	530 548	4	540
500	457	1220	650	1300	500	670	715	620 650	20-φ28 20-φ34	31.5	582 609	4	690
600	508	1370	650	1470	600	780	840	725 770	20-φ31 20-φ37	36	682 720	5	840

BS5150 RESILIENT SEATED GATE VALVE OS&Y

- Cast or Ductile Iron Body, Bonnet, Wedge and Gland,
- Resilient Wedge, Rising Stem, Bolted Bonnet,
- Fusion Bonded Epoxy Internally and Externally
- Flanged Ends to BS 4504, EN1092
- Design and Manufacture to BS5150

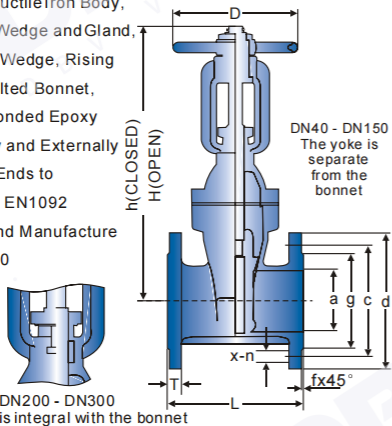

Face to Face	BS5163, ISO5752 Series 3
End Flange	BS4504, BS EN1092
Class	PN10/16

SIZE (DN)	L	h	H	D	a	d	c	x-n	T	g	f	W.T (kg)	
40	165	320	365	180	40	150	110	4-φ19	19	84	3	16	
50	178	330	385	180	50	165	125	4-φ19	19	99	3	17	
65	190	345	415	180	65	185	145	4-φ19	19	118	3	20	
80	203	435	518	205	80	200	160	8-φ19	19	132	3	29	
100	229	465	570	240	100	220	180	8-φ19	19	156	3	34	
125	254	615	745	240	125	250	210	8-φ19	19	184	3	42	
150	267	630	790	280	150	285	240	8-φ23	19	211	3	58	
200	292	780	990	320	200	340	295	8-φ23 12-φ23	20	266	3	83	
250	330	915	1175	360	250	395	405	350 355	12-φ23 12-φ28	22	319	3	138
300	356	1080	1390	450	300	445	460	400 410	12-φ23 12-φ28	24.5	370	4	192

ANSI METAL SEATED GATE VALVE NRS

- Cast or Ductile Iron Body, Bonnet, Wedge and Gland,
- Metal Seated, Non Rising Stem, Bolted Bonnet,
- Fusion Bonded Epoxy Internally and Externally
- Flanged Ends to ANSI B16.1, CL125, B16.5 CL150
- Design and Manufacture to ANSI

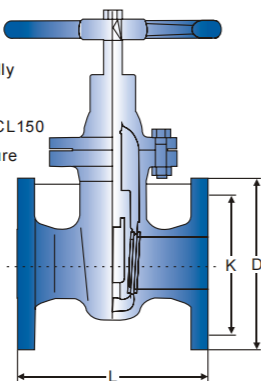

Face to Face	ANSI B16.10
End Flange	ANSI B16.1 CL125, ANSI B16.5 CL150
Class	ANSI 125, ANSI 150

SIZE (in.)	L	D	K	HOLE DIA.	HOLE NO	W.T (kg)
2"	178	152	121	19	4	18
2-1/2"	190	178	140	19	4	22
3"	203	191	152	19	4	28
4"	229	229	191	19	8	40
5"	254	254	216	22	8	56
6"	267	279	241	22	8	58
8"	292	343	298	22	8	116
10"	330	406	362	25	12	160
12"	356	483	432	25	12	225

Gate Valve

ANSI METAL SEATED GATE VALVE OS&Y

- Cast or Ductile Iron Body, Bonnet, Wedge and Gland,
- Metal Seated, Rising Stem, Bolted Bonnet,
- Fusion Bonded Epoxy Internally and Externally
- Flanged Ends to ANSI B16.1, CL125, B16.5 CL150
- Design and Manufacture to ANSI

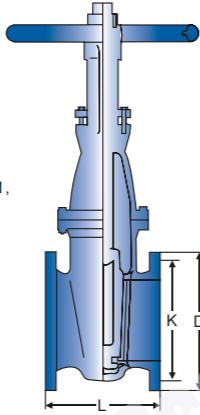

Face to Face	ANSI B16.10
End Flange	ANSI B16.1 CL125, ANSI B16.5 CL150
Class	ANSI 125, ANSI 150

SIZE (in.)	L	D	K	HOLE DIA.	HOLE NO	W.T (kg)	Unit: mm
2"	178	152	121	19	4	18	
2-1/2"	190	178	140	19	4	22	
3"	203	191	152	19	4	31	
4"	229	229	191	19	8	44	
5"	254	254	216	22	8	58	
6"	267	279	241	22	8	66	
8"	292	343	298	22	8	120	
10"	330	406	362	25	12	163	
12"	356	483	432	25	12	225	

BS5163 METAL SEATED GATE VALVE NRS

- Cast or Ductile Iron Body, Bonnet, Wedge and Gland,
- Metal Seated, Non Rising Stem, Bolted Bonnet,
- Fusion Bonded Epoxy Internally and Externally
- Flanged Ends to BS Table E/D, BS4504
- Design and Manufacture to BS5163:1986, BS5150

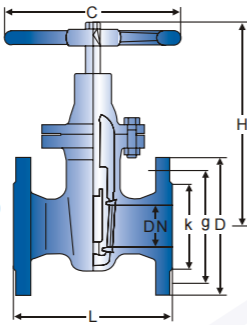

Face to Face	BS5150, ISO5752 Series 3
End Flange	BS4504, EN1092
Class	PN10/16

SIZE (DN)	L	H	D	g	k	C	HOLE DIA.	HOLE NO	W.T (kg)	Unit: mm
50	178	286	165	102	125	178	4	18	19	
65	190	310	185	122	145	178	4	18	21	
80	203	356	200	138	160	203	8	18	30	
100	229	380	220	158	180	245	8	18	45	
125	254	400	250	188	210	254	8	18	56	
150	267	486	285	212	240	305	8	22	65	
200	292	610	340	268	295	356	12	22	125	
250	330	705	405	320	355	405	12	26	165	
300	356	815	460	378	410	457	12	26	230	

BS5163 METAL SEATED GATE VALVE OS&Y

- Cast or Ductile Iron Body, Bonnet, Wedge and Gland,
- Metal Seated, Non Rising Stem, Bolted Bonnet,
- Fusion Bonded Epoxy Internally and Externally
- Flanged Ends to BS Table E/D, BS4504
- Design and Manufacture to BS5163:1986, BS5150

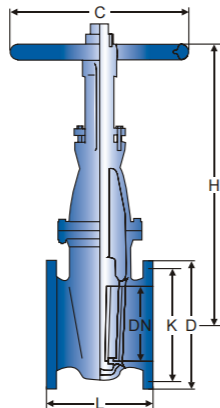

Face to Face	BS5163:1986, BS5150
End Flange	BS4504, EN1092
Class	PN10/16

SIZE (DN)	L	H	D	k	C	HOLE DIA.	HOLE NO	W.T (kg)	Unit: mm
50	178	286	165	125	178	4	18	18	
65	190	310	185	145	178	4	18	22	
80	203	356	200	160	203	8	18	31	
100	229	380	220	180	245	8	18	44	
125	254	400	250	210	254	8	18	58	
150	267	486	285	240	305	8	22	66	
200	292	610	340	295	356	12	22	120	
250	330	705	405	355	405	12	26	163	
300	356	815	460	410	457	12	26	225	

DIN3202 F4 METAL SEATED GATE VALVE NRS

- Cast or Ductile Iron Body, Bonnet, Wedge and Gland,
- Metal Seated, Non Rising Stem, Bolted Bonnet,
- Fusion Bonded Epoxy Internally and Externally
- Flanged Ends to DIN2532/2533, BS EN1092
- Design and Manufacture to DIN3352

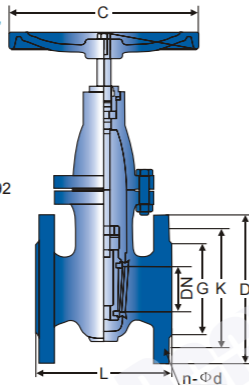

Face to Face	DIN3202 F4, EN558 Series 14
End Flange	DIN2532/2533, BS EN1092
Class	PN10/16

SIZE (DN)	L	D		K		G		C	n-φd		W.T (Kg) Unit: mm
		PN10	PN16	PN10	PN16	PN10	PN16		PN10	PN16	
50	150	165	165	125	125	102	102	180	4-18	4-18	12
65	170	185	185	145	145	122	122	180	4-18	4-18	14
80	180	200	200	160	160	138	138	200	4-18	8-18	20
100	190	220	220	180	180	158	158	250	8-18	8-18	26
125	200	250	250	210	210	188	188	280	8-18	8-18	36
150	210	285	285	240	240	212	212	280	8-23	8-23	46
200	230	340	340	295	295	268	268	340	8-23	12-23	70
250	250	395	405	350	355	320	320	340	12-23	12-27	108
300	270	445	460	400	410	370	378	400	12-23	12-27	150
350	290	505	520	460	470	430	438	450	16-23	16-27	278

DIN3202 F4 METAL SEATED GATE VALVE OS&Y

- Cast or Ductile Iron Body, Bonnet, Wedge and Gland,
- Metal Seated, Rising Stem Bolted Bonnet,
- Fusion Bonded Epoxy Internally and Externally
- Flanged Ends to DIN2532/2533, BS EN1092
- Design and Manufacture to DIN3352

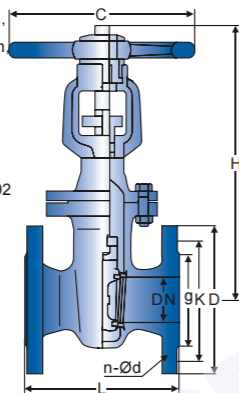

Face to Face	DIN3202 F4, EN558 Series 14
End Flange	DIN2532/2533, BS EN1092
Class	PN10/16

SIZE (DN)	L	D		K		G		B	H	C	n-φd		W.T (Kg) Unit: mm
		PN10	PN16	PN10	PN16	PN10	PN16				PN10	PN16	
50	150	165	165	125	125	102	102	20	395	178	4-18	4-18	16
65	170	185	185	145	145	122	122	20	453	178	4-18	4-18	22
80	180	200	200	160	160	138	138	20	496	203	4-18	8-18	26
100	190	220	220	180	180	158	158	22	566	254	8-18	8-18	33
125	200	250	250	210	210	188	188	22	685	254	8-18	8-18	50
150	210	285	285	240	240	212	212	22	742	305	8-23	8-23	60
200	230	340	340	295	295	268	268	24	961	356	8-23	12-23	96
250	250	395	405	350	355	320	320	26	1138	405	12-23	12-27	145
300	270	445	460	400	410	370	378	28	1266	457	12-23	12-27	190

DIN3202 F5 METAL SEATED GATE VALVE NRS

- Cast or Ductile Iron Body, Bonnet, Wedge and Gland,
- Metal Seated, Non Rising Stem, Bolted Bonnet,
- Fusion Bonded Epoxy Internally and Externally
- Flanged Ends to DIN 3202 F5 (EN558-1 SERIE15)
- Design and Manufacture to DIN 3352

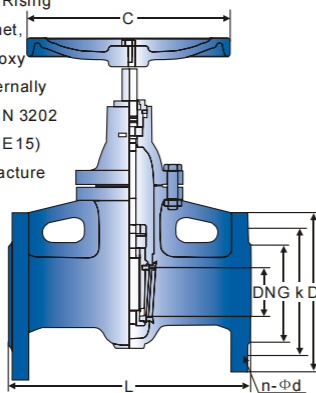

Face to Face	DIN3202 F5, EN558 Series 15
End Flange	DIN2532/2533, BS EN1092
Class	PN10/16

SIZE (DN)	L	D		K		G		C	n-φd		W.T (Kg) Unit: mm
		PN10	PN16	PN10	PN16	PN10	PN16		PN10	PN16	
50	150	165	165	125	125	102	102	180	4-18	4-18	18
65	170	185	185	145	145	122	122	180	4-18	4-18	22
80	180	200	200	160	160	138	138	200	4-18	8-18	28
100	190	220	220	180	180	158	158	250	8-18	8-18	35
125	200	250	250	210	210	188	188	280	8-18	8-18	52
150	210	285	285	240	240	212	212	280	8-23	12-23	66
200	230	340	340	295	295	268	268	340	8-23	8-23	108
250	250	395	405	350	355	320	320	340	12-23	12-27	168
300	270	445	460	400	410	370	378	400	12-23	12-27	245

Gate Valve

ANSI GLOBE VALVE

- Cast or Ductile Iron Body, Bonnet, Disc and Gland,
- Metal Seated, Rising Stem, Bolted Bonnet,
- Flanged Ends to ANSI B16.1, CL125, B16.5 CL150
- Design and Manufacture to ANSI

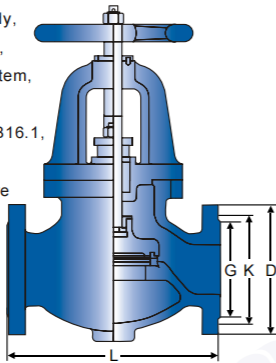

Face to Face	ANSI B16.10
End Flange	ANSI B16.1 CL125, ANSI B16.5 CL150
Class	ANSI 125, ANSI 150

SIZE (in.)	2"	2-1/2"	3"	4"	5"	6"	8"	10"	12"
------------	----	--------	----	----	----	----	----	-----	-----

	Unit: mm								
L	203	216	241	292	330	356	495	622	698
D	152	178	191	229	254	279	343	406	483
K	121	140	152	191	216	241	298	362	432
G	92	105	127	157	186	213	270	324	381
HOLE NO.	4	4	4	8	8	8	8	12	12
HOLE DIA.	19	19	19	19	22	22	22	25	25
W.T(KG)	17	24	32	55	61	96	136	178	255

BS5152 GLOBE VALVE

- Cast or Ductile Iron Body, Bonnet, Disc and Gland,
- Metal Seated, Rising Stem, Bolted Bonnet,
- Flanged Ends to BS4504
- Design and Manufacture to BS5152

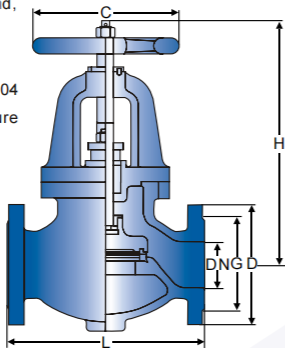

Face to Face	BS5152
End Flange	BS4504, EN1092
Class	PN10/16

SIZE (DN)	50	65	80	100	125	150	200
-----------	----	----	----	-----	-----	-----	-----

	Unit: mm						
L	203	216	241	292	330	356	495
D	165	185	200	220	250	285	340
C	203	203	254	254	305	305	356
G	102	122	138	158	188	212	268
H	273	298	311	352	375	425	514
HOLE NO.	4	4	8	8	8	8	12
HOLE DIA.	18	18	18	18	18	22	22
W.T(KG)	17	24	32	55	61	96	136

DIN3202 F1 GLOBE VALVE

- Cast or Ductile Iron Body, Bonnet, Disc and Gland,
- Metal Seated, Rising Stem, Bolted Bonnet,
- Flanged Ends to DIN2532/2533 BS EN1092
- Design and Manufacture to DIN 3202 F1

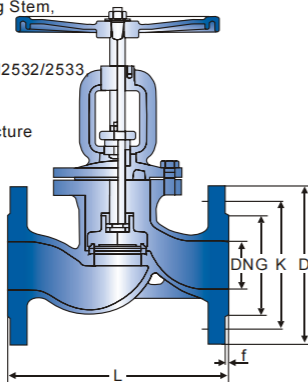

Face to Face	DIN3202 F1
End Flange	DIN2532/2533, BS EN1092
Class	PN10/16

50 ≤ DN ≤ 250 f=3mm; DN ≥ 300 f=4mm

SIZE (DN)	L	D		K		G		n-φd		W.T (Kg)
		PN10	PN16	PN10	PN16	PN10	PN16	PN10	PN16	

	Unit: mm									
50	230	165	165	125	125	102	102	4-18	4-18	18
65	290	185	185	145	145	122	122	4-18	4-18	25
80	310	200	200	160	160	138	138	4-18	8-18	34
100	350	220	220	180	180	158	158	8-18	8-18	57
125	400	250	250	210	210	188	188	8-18	8-18	64
150	480	285	285	240	240	212	212	8-23	8-23	101
200	600	340	340	295	295	268	268	8-23	12-23	143
250	730	395	405	350	355	320	320	12-23	12-27	185
300	850	445	460	400	410	370	378	12-23	12-27	265

DIN3202 F32 ANGLE PATTERN GLOBE VALVE

- Cast or Ductile Iron Body, Bonnet, Disc and Gland
- Angle Pattern, Rising Stem, Bolted Bonnet,
- Flanged Ends to DIN25 32/2533, BS EN1092
- Design and Manufacture to DIN 3202 F32

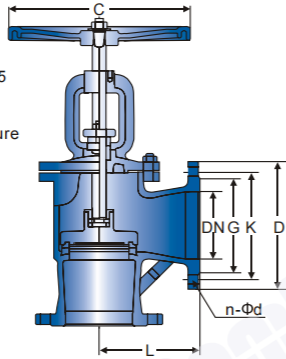

Face to Face	DIN3202 F32
End Flange	DIN2532/2533, BS EN1092
Class	PN10/16

SIZE (DN)	L	D		K		G		C	n-Φd		W.T (Kg) Unit: mm
		PN10	PN16	PN10	PN16	PN10	PN16		PN10	PN16	
50	125	165	165	125	125	99	99	200	4-18	4-18	17
65	145	185	185	145	145	118	118	200	4-18	4-18	24
80	155	200	200	160	160	135	132	250	4-18	8-18	33
100	175	220	220	180	180	156	156	250	8-18	8-18	55
125	200	250	250	210	210	184	184	280	8-18	8-18	62
150	225	285	285	240	240	211	211	340	8-23	8-23	98
200	275	340	340	295	295	266	266	340	8-23	12-23	137
250	325	395	405	350	355	319	319	400	12-23	12-27	178
300	375	445	460	400	410	370	370	450	12-23	12-27	258

ANSI SWING CHECK VALVE

- Cast or Ductile Iron Body, Swing Flanged,
- Metal Seated, Bolted Bonnet,
- Flanged Ends to ANSI B16.1, CL125, B16.5 CL150
- Design and Manufacture to ANSI

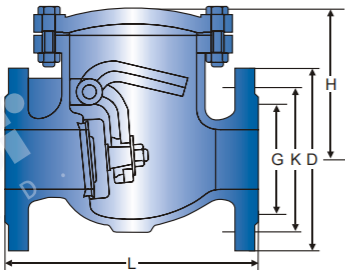

Face to Face	ANSI B16.10, MSSSP-71
End Flange	ANSI B16.1 CL125, ANSI B16.5 CL150
Class	ANSI 125, ANSI 150

SIZE (in.)	2"	2-1/2"	3"	4"	5"	6"	8"	10"	12"	Unit: mm
H	120	135	148	180	205	230	258	391	427	
L	203	216	241	292	330	356	495	622	698	
D	152	178	191	229	254	279	343	406	483	
K	121	140	152	191	216	241	298	362	432	
G	92	105	127	157	186	213	270	324	381	
HOLE NO.	4	4	4	8	8	8	8	12	12	
HOLE DIA.	19	19	19	19	22	22	22	25	25	
W.T(kg)	13	18	22	36	50	60	110	170	230	

ANSI SWING CHECK VALVE WITH COUNTERWEIGHT OR LEVER

- Cast or Ductile Iron Body, Swing Flanged
- Metal Seated, Bolted Bonnet, With Counterweight or Lever/Spring
- Flanged Ends to ANSI B16.1, CL125, B16.5 CL150
- Design and Manufacture to ANSI

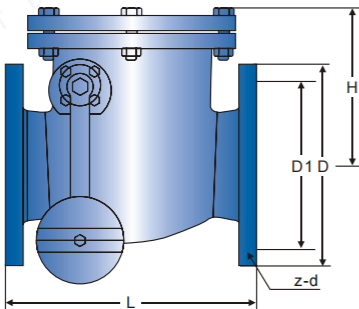

Face to Face	ANSI B16.10, MSSSP-71
End Flange	ANSI B16.1 CL125, ANSI B16.5 CL150
Class	ANSI 125, ANSI 150

SIZE (in.)	D	D1	L	Z-d	H	Unit: mm
2"	152	120.5	203	4-19	136	
2-1/2"	178	139.5	216	4-19	147	
3"	191	152.5	241	4-19	158	
4"	229	190.5	292	8-19	184	
5"	254	216	330	8-22	212	
6"	279	241.5	356	8-22	227	
8"	343	298.5	495	8-22	263	
10"	406	362	622	12-25	304	
12"	483	432	698	12-25	335	
14"	533	476	787	12-29	355	
16"	597	539.5	914	12-29	394	

Check Valve

BS SWING CHECK VALVE

- Cast or Ductile Iron Body, Swing Flanged,
- Metal Seated, Bolted Bonnet,
- Flanged Ends to BS4504 Table E/D
- Design and Manufacture to BS5153

Face to Face	BS5153
End Flange	BS4504, EN 1092
Class	PN10/16

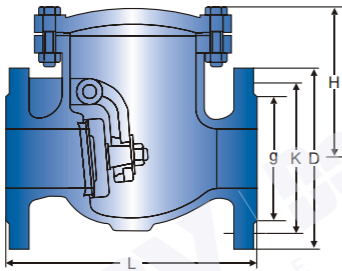

SIZE (in.)	2"	2-1/2"	3"	4"	5"	6"	8"	10"	12"	Unit: mm
L	203	216	241	292	330	356	495	622	698	
H	120	135	148	180	205	230	258	391	427	
D	165	185	200	220	250	285	340	405	460	
g	102	122	138	158	188	212	268	320	378	
K	125	145	160	180	210	240	295	355	410	
HOLE NO.	4	4	8	8	8	8	12	12	12	
HOLE DIA.	18	18	18	18	18	22	22	26	26	
W.T(kg)	13	18	22	36	50	60	110	170	230	

DIN3202-F6 SWING CHECK VALVE

- Cast or Ductile Iron Body, Swing Flanged,
- Metal Seated, Bolted Bonnet,
- Flanged Ends to DIN2532/2533, BS EN 1092
- Design and Manufacture to DIN 3202 F6

Face to Face	DIN3202 F6
End Flange	DIN2532/2533, BS EN 1092
Class	PN10/16

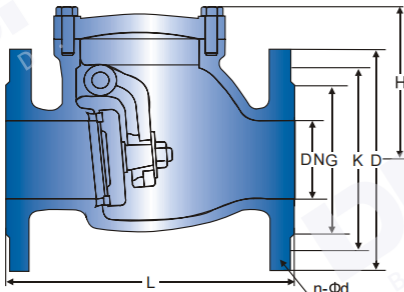

SIZE (DN)	L	H	D		K		G		n-Ød		W.T (Kg)	Unit: mm
			PN10	PN16	PN10	PN16	PN10	PN16	PN10	PN16		
50	200	125	165	165	125	125	102	102	4-18	4-18	13	
65	240	130	185	185	145	145	122	122	4-18	4-18	17	
80	260	160	200	200	160	160	138	138	4-18	8-18	24	
100	300	185	220	220	180	180	158	158	8-18	8-18	32	
125	350	195	250	250	210	210	188	188	8-18	8-18	45	
150	400	205	285	285	240	240	212	212	8-23	8-23	62	
200	500	285	340	340	295	295	268	268	8-23	12-23	117	
250	600	320	396	405	350	355	320	320	12-23	12-27	190	
300	700	340	445	460	400	410	370	378	12-23	12-27	198	
350	800	355	505	520	460	470	430	438	16-23	16-27	288	
400	900	394	656	580	515	525	482	490	16-27	16-30	345	

DIN3202-F1 LIFT CHECK VALVE

- Cast or Ductile Iron Body, Piston Lift Type,
- Metal Seated, Bolted Bonnet, Flanged Ends
- Flanged Ends to DIN2532/2533, BS EN 1092
- Design and Manufacture to DIN 3202 F1

Face to Face	DIN3202 F1
End Flange	DIN2532/2533, BS EN 1092
Class	PN10/16

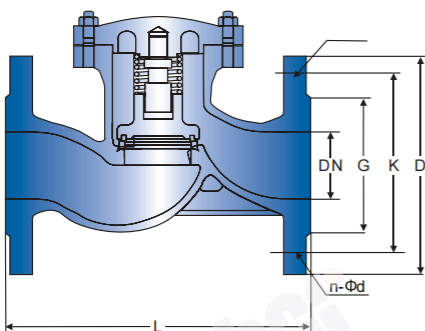

SIZE (DN)	L	D		K		G		n-Ød		W.T (Kg)	Unit: mm
		PN10	PN16	PN10	PN16	PN10	PN16	PN10	PN16		
50	230	165	165	125	125	102	102	4-18	4-18	12	
65	290	185	185	145	145	122	122	4-18	4-18	15	
80	310	200	200	160	160	138	138	4-18	8-18	22	
100	350	220	220	180	180	158	158	8-18	8-18	29	
125	400	250	250	210	210	188	188	8-18	8-18	42	
150	480	285	285	240	240	212	212	8-23	8-23	59	
200	600	340	340	295	295	268	268	8-23	12-23	113	
250	730	395	405	350	355	320	320	12-23	12-27	178	
300	850	445	460	400	410	370	378	12-23	12-27	182	

DUAL PLATE WAFER CHECK VALVE

- Cast or Ductile Iron Body, Spring Loaded
- Dual Plate, Wafer Ends
- Flanged Ends to BS4504
- Design and Manufacture to BS5153

Face to Face	DIN3202
End Flange	DIN2532/2533, BS EN1092
Class	PN10/16

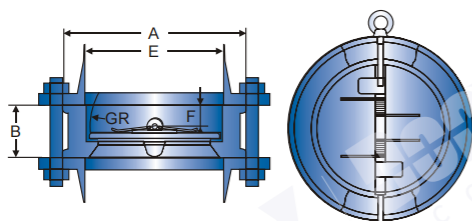

SIZE (DN)	A	E	B	GR	F	Unit: mm
50	107	65	43	28.8	19	
65	127	80	46	36.1	20	
80	142	94	64	43.4	28	
100	162	117	64	52.8	29	
125	192	145	70	65.7	30	
150	218	170	76	78.6	31	
200	273	224	89	104.4	33	
250	328	265	114	127	40	
300	378	310	114	148.3	43	
350	438	360	127	172.4	45	
400	489	410	140	197.4	52	
450	539	450	152	217.8	58	
500	594	505	152	241	58	
600	695	624	178	295.4	73	

CV COEFFICIENTS* (For estimating purposes only)

Gate Valves	2"	2-1/2"	3"	4"	5"	6"	8"	10"	12"	14"	16"	18"	20"	24"	30"	36"
Gate Valves	327	480	742	1314	2129	3175	5691	8970	13351	16277	21562	28715	35760	52165	82563	119910
Globe Valves	50	74	114	202	327	487	1376	—	—	—	—	—	—	—	—	—
Swing Check Valves	131	192	297	526	852	1270	2276	3588	5340	6511	8625	11486	14304	20866	—	—

SWING FLEX CHECK VALVE

- Cast Iron or Steel Body, Swing Type Disc, Resilient Seated
- Suitable for Horizontal or Vertical Lines
- Sewage or Water Treatment Applications

Face to Face	DBV Standard
End Flange	ISO, EN or ASME
Class	ANSI125/150, PN10/PN16/25

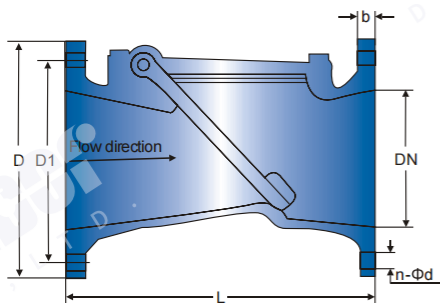

SIZE (DN)	L	D			D1			Unit: mm
		PN1.0	PN1.6	PN2.5	PN1.0	PN1.6	PN2.5	
50	203	165	165	165	125	125	125	
65	216	185	185	185	145	145	145	
80	241	200	200	200	160	160	160	
100	292	220	220	235	180	180	190	
150	356	285	285	300	240	240	250	
200	495	340	340	360	295	295	310	
250	622	395	405	425	350	355	370	
300	698	445	460	485	400	410	430	
350	787	505	520	555	460	470	490	
400	914	565	580	620	515	525	550	
450	978	615	640	670	565	585	600	
500	978	670	715	730	620	650	660	
600	1295	780	840	845	725	770	770	

SIZE (DN)	b			D2			n-Φd			Unit: mm
	PN1.0	PN1.6	PN2.5	PN1.0	PN1.6	PN2.5	PN1.0	PN1.6	PN2.5	
50	20	20	20	102	102	99	4-17.5	4-17.5	4-18	
65	20	20	22	122	122	118	4-17.5	4-17.5	8-18	
80	22	22	24	133	133	132	8-17.5	8-17.5	8-18	
100	24	24	24	158	158	156	8-17.5	8-17.5	8-22	
150	26	26	28	212	212	211	8-22	8-22	8-26	
200	28	30	30	268	268	274	8-22	12-22	12-26	
250	28	32	32	320	320	330	12-22	12-26	12-30	
300	28	32	34	370	370	389	12-22	12-26	16-30	
350	30	36	38	430	430	448	16-22	16-26	16-33	
400	32	38	40	482	482	503	16-26	16-30	16-36	
450	32	40	42	532	550	548	20-26	20-30	20-36	
500	34	42	44	585	585	609	20-26	20-33	20-36	
600	36	48	46	685	685	720	20-30	20-36	20-39	

Check Valve

NOZZLE CHECK VALVE

- Cast Iron or Steel Body, Spring Loaded, Watertight Seating
- Slow Closing, Energy Saving, Non-slam
- Suitable for Horizontal or Vertical Lines
- Sewage or Water Treatment Applications

Face to Face	API 6D (Short Pattern)
End Flange	ISO, EN or ASME
Class	ANSI125/150, PN10/PN16

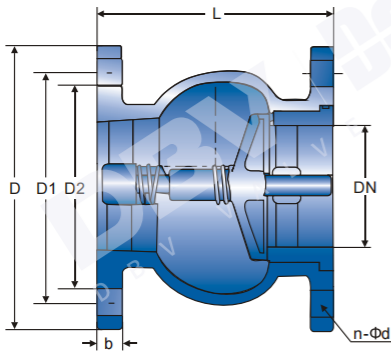

SIZE (DN)	L	D		D1		Unit: mm
		PN1.0	PN1.6	PN1.0	PN1.6	
40	112	150	150	110	110	
50	120	165	165	125	125	
65	130	185	185	145	145	
80	150	200	200	160	160	
100	165	220	220	180	180	
125	190	250	250	210	210	
150	210	285	285	240	240	
200	255	340	340	295	295	
250	310	395	405	350	355	
300	362	445	460	400	410	
350	380	505	520	460	470	
400	450	565	580	515	525	
450	545	615	640	565	585	
500	580	670	715	620	650	

SIZE (DN)	b		D2		n-φd		Unit: mm
	PN1.0	PN1.6	PN1.0	PN1.6	PN1.0	PN1.6	
40	18	18	88	88	4-17.5	4-17.5	
50	20	20	102	102	4-17.5	4-17.5	
65	20	20	122	122	4-17.5	4-17.5	
80	22	22	133	133	8-17.5	8-17.5	
100	24	24	158	158	8-17.5	8-17.5	
125	26	26	184	184	8-17.5	8-17.5	
150	26	26	212	212	8-22	8-22	
200	28	30	268	268	8-22	12-22	
250	28	32	320	320	12-22	12-26	
300	28	32	370	370	12-22	12-26	
350	30	36	430	430	16-22	16-26	
400	32	38	482	482	16-26	16-30	
450	32	40	532	550	20-26	20-30	
500	34	42	585	585	20-26	20-33	

NON SLAM CHECK VALVE

- Cast Iron or Steel Body, Spring Loaded, Watertight Seating
- Slow Closing, Energy Saving, Non-slam
- Suitable for Horizontal or Vertical Lines
- Sewage or Water Treatment Applications

Face to Face	API 6D (Short Pattern)
End Flange	ISO, EN or ASME
Class	ANSI125/150, PN10/PN16/PN25

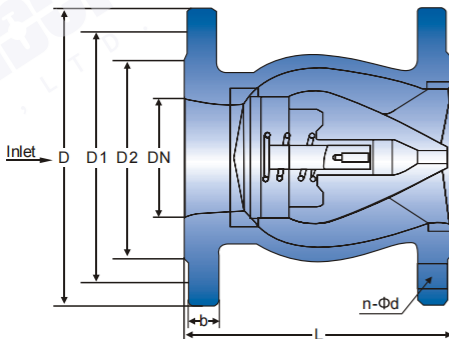

SIZE (DN)	L	D			D1			Unit: mm
		PN1.0	PN1.6	PN2.5	PN1.0	PN1.6	PN2.5	
50	120	165	165	165	125	125	125	
65	150	185	185	185	145	145	145	
80	180	200	200	200	160	160	160	
100	240	220	220	235	180	180	190	
125	300	250	250	270	210	210	220	
150	350	285	285	300	240	240	250	
200	450	340	340	360	295	295	310	
250	500	395	405	425	350	355	370	
300	550	445	460	485	400	410	430	
350	575	505	520	555	460	470	490	
400	600	565	580	620	515	525	550	
450	650	615	640	670	565	585	600	
500	700	670	715	730	620	650	660	

SIZE (DN)	b			D2			n-φd			Unit: mm
	PN1.0	PN1.6	PN2.5	PN1.0	PN1.6	PN2.5	PN1.0	PN1.6	PN2.5	
50	20	20	20	102	102	99	4-17.5	4-17.5	4-18	
65	20	20	22	122	122	118	4-17.5	4-17.5	8-18	
80	22	22	24	133	133	132	8-17.5	8-17.5	8-18	
100	24	24	24	158	158	156	8-17.5	8-17.5	8-22	
125	26	26	26	184	184	184	8-17.5	8-17.5	8-26	
150	26	26	28	212	212	211	8-22	8-22	8-26	
200	28	30	30	268	268	274	8-22	12-22	12-26	
250	28	32	32	320	320	330	12-22	12-26	12-30	
300	28	32	34	370	370	389	12-22	12-26	16-30	
350	30	36	38	430	430	448	16-22	16-26	16-33	
400	32	38	40	482	482	503	16-26	16-30	16-36	
450	32	40	42	532	550	548	20-26	20-30	20-36	
500	34	42	44	585	585	609	20-26	20-33	20-36	

BALL TYPE CHECK VALVE

- Cast Iron or Steel Body, Ball Type Disc
- Available in Uni-body or Bolted Split Cover
- Suitable for Horizontal or Vertical Lines
- Sewage or Water Treatment Applications

Face to Face	DBV Standard
End Flange	ISO, EN or ASME
Class	PN10/PN16/25

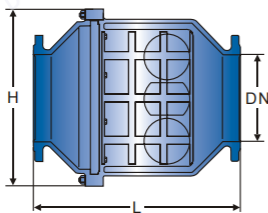
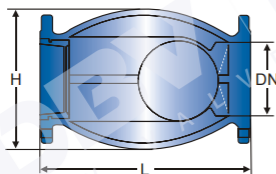
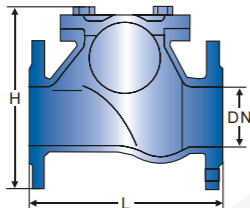

SIZE (DN)	L	H	D		D1		Unit: mm
			PN1.0	PN1.6	PN1.0	PN1.6	
50	216	185	165	165	125	125	
65	241	210	185	185	145	145	
80	293	245	200	200	160	160	
100	305	280	220	220	180	180	
125	381	335	250	250	210	210	
150	403	400	285	285	240	240	
200	495	495	340	340	295	295	
250	622	600	395	405	350	355	
300	698	715	445	460	400	410	
350	787	800	505	520	460	470	

SIZE (DN)	L	H	D		D1		Unit: mm
			PN1.0	PN1.6	PN1.0	PN1.6	
50	250	180	165	165	125	125	
65	280	210	185	185	145	145	
80	310	225	200	200	160	160	
100	350	245	220	220	180	180	
125	400	280	250	250	210	210	
150	450	320	285	285	240	240	
200	550	380	340	340	295	295	
250	650	450	395	405	350	355	
300	750	510	445	460	400	410	

SIZE (DN)	L	H	D		D1		Unit: mm
			PN1.0	PN1.6	PN1.0	PN1.6	
200	550	510	340	340	295	295	
250	650	570	395	405	350	355	
300	750	640	445	460	400	410	
350	850	715	505	520	460	470	
400	950	815	565	580	515	525	
450	1050	825	615	640	565	585	
500	1150	980	670	715	620	650	
600	1350	1155	780	840	725	770	
700	1450	1260	895	910	840	840	
800	1650	1350	1015	1025	950	950	
900	1900	1660	1115	1125	1050	1050	
1000	2100	1700	1230	1255	1160	1170	

BALL TYPE RUBBER LINED CHECK VALVE

- Cast Iron or Steel Body, Rubber Lined
- Ball Type Disc, Bolted Cover
- Suitable for Horizontal or Vertical Lines
- Sewage or Water Treatment Applications

Face to Face	DBV Standard
End Flange	ISO, EN or ASME
Ratings	PN6, PN10

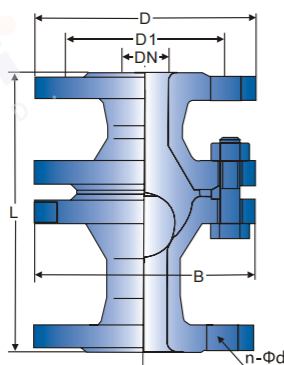

SIZE (DN)	Nominal pressure MPa	Working pressure MPa	L	D	B	n-Φd	D1	W.T (kg)	Unit: mm
15	1.0	1.0	150	150	95	4-14	65	3	
20	1.0	1.0	150	150	100	4-14	75	3.5	
25	1.0	1.0	152	152	125	4-14	85	5	
40	1.0	1.0	165	165	145	4-18	110	7.5	
50	1.0	1.0	178	178	165	4-18	125	10.5	
65	1.0	1.0	190	190	205	8-18	145	16.5	
80	1.0	1.0	203	203	240	8-18	160	21.5	
100	1.0	1.0	229	229	270	8-18	180	38	
125	1.0	1.0	325	325	286	8-18	210	55	
150	0.6	0.6	394	394	380	8-22	240	78.5	
200	0.6	0.6	457	457	440	8-22	295	104	

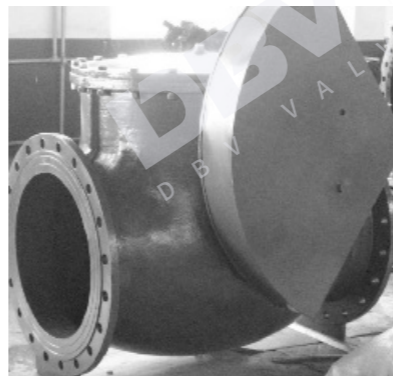

Check Valve

SLOW CLOSING CHECK VALVE

- Long Pattern, Cast Iron or Steel Body, Slow Closing, Micro-resistance
- With Light Flap or Disc, Energy Saving, Non slam
- Suitable for Sewage Treatment
- Designed to ISO Standards,

Face to Face	DBV Standard
End Flange	ISO, EN or ASME
Ratings	PN10, PN16, PN25

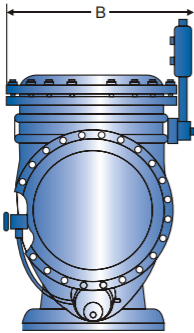
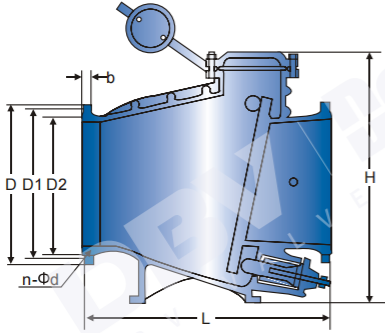

SIZE (DN)	L	H	B	D			D1		
				PN1.0	PN1.6	PN2.5	PN1.0	PN1.6	PN2.5
40	200	300	220	150	150	150	110	110	110
50	230	300	270	165	165	165	125	125	125
65	290	320	290	185	185	185	145	145	145
80	310	354	300	200	200	200	160	160	160
100	350	350	320	220	220	235	180	180	190
125	400	380	340	250	250	270	210	210	220
150	480	500	410	285	285	300	240	240	250
200	500	580	450	340	340	360	295	295	310
250	600	670	550	395	405	425	350	355	370
300	700	730	580	445	460	485	400	410	430
350	800	820	630	505	520	555	460	470	490
400	900	920	700	565	580	620	515	525	550
450	1000	950	800	615	640	670	565	585	600
500	1100	1100	900	670	715	730	620	650	660
600	1300	1200	990	780	840	845	725	770	770
700	1400	1550	1120	895	910	960	840	840	875
800	1500	1700	1300	1015	1025	1085	950	950	990

Unit: mm

SIZE (DN)	b			D2			n-φd		
	PN1.0	PN1.6	PN2.5	PN1.0	PN1.6	PN2.5	PN1.0	PN1.6	PN2.5
40	18	18	18	88	88	84	4-17.5	4-17.5	4-18
50	20	20	20	102	102	99	4-17.5	4-17.5	4-18
65	20	20	22	122	122	118	4-17.5	4-17.5	8-18
80	22	22	24	133	133	132	8-17.5	8-17.5	8-18
100	24	24	24	158	158	156	8-17.5	8-17.5	8-22
125	26	26	26	184	184	184	8-17.5	8-17.5	8-26
150	26	26	28	212	212	211	8-22	8-22	8-26
200	28	30	30	268	268	274	8-22	12-22	12-26
250	28	32	32	320	320	330	12-22	12-26	12-30
300	28	32	34	370	370	389	12-22	12-26	16-30
350	30	36	38	430	430	448	16-22	16-26	16-33
400	32	38	40	482	482	503	16-26	16-30	16-36
450	32	40	42	532	550	548	20-26	20-30	20-36
500	34	42	44	585	585	609	20-26	20-33	20-36
600	36	48	46	685	685	720	20-30	20-36	20-39
700	40	54	50	800	800	820	24-30	24-36	24-42
800	44	58	54	905	905	928	24-33	24-39	24-48

Unit: mm

MICRO-RESISTANCE SLOW CLOSING NON SLAM CHECK VALVE

- Butterfly or Short Pattern, Cast Iron or Steel Body,
- Slow Closing, Micro Flow Resistance
- Equipped With Micro-regulation Valves and Oil Tank,
- Energy Saving, Non slam
- Suitable for Horizontal or Vertical Lines
- Sewage or Water Treatment Applications

Face to Face	DBV Standard
End Flange	ISO, EN or ASME
Ratings	PN10, PN16, PN25

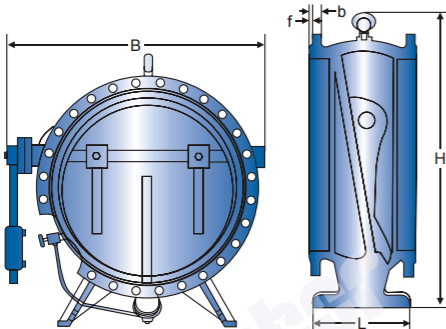

SIZE (DN)	L	H	B	D		D1		D2		b		f		n-φd	
				PN 1.6	PN 2.5	PN 1.6	PN 2.5	PN 1.6	PN 2.5	PN 1.6	PN 2.5	PN 1.6	PN 2.5	PN 1.6	PN 2.5
200	230	550	450	335	360	295	310	265	278	26	34	3	12-23	12-25	
250	250	630	520	405	425	355	370	320	332	30	36	3	12-25	12-30	
300	270	690	590	460	485	410	430	375	390	30	40	4	12-25	16-30	
350	290	780	670	520	550	470	490	435	448	34	44	4	16-25	16-34	
400	310	860	750	580	610	525	550	485	505	36	48	4	16-30	16-34	
450	330	910	780	640	660	585	600	545	555	40	50	4	20-30	20-34	
500	350	980	850	705	730	650	660	608	610	44	52	4	20-34	20-41	
600	390	1070	970	840	840	770	770	718	718	48	56	5	20-41	24-41	
700	430	1220	1080	910	955	840	875	788	815	50	60	5	24-41	24-48	
800	470	1320	1200	1020	1070	950	990	898	930	52	64	5	24-41	24-48	
900	510	1430	1300	1120	1180	1050	1090	998	1025	54	66	5	28-41	28-54	
1000	550	1550	1450	1255	1305	1170	1210	1110	1140	56	68	5	28-48	28-58	
1200	630	1800	1670	1485	1525	1390	1420	1325	1350	58	72	5	32-54	32-58	
1400	710	1980	1880	1685	1750	1590	1640	1525	1560	60	78	5	36-54	36-65	
1600	790	2150	1950	1930		1820		1750		68	5	40-58			

Unit: mm

MICRO-RESISTANCE SLOW CLOSING BUTTERFLY TYPE CHECK VALVE

- Butterfly Type Short Pattern, Cast Iron or Steel Body,
- Slow Closing, Micro Flow Resistance
- With Micro Adjusted Valves and Oil Tank,
- Energy Saving, Non slam
- Suitable for Horizontal or Vertical Lines
- Sewage or Water Treatment Applications

Face to Face	DBV Standard
End Flange	ISO, EN or ASME
Ratings	PN10, PN16, PN25

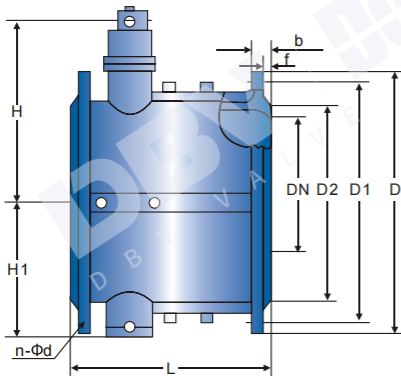

SIZE (DN)	L	H	H1	D		D1		D2		b		f		n- d	
				PN 1.6	PN 2.5	PN 1.6	PN 2.5	PN 1.6	PN 2.5	PN 1.6	PN 2.5	PN 1.6	PN 2.5	PN 1.6	PN 2.5
Unit: mm															
40	140	200	88	145	145	110	110	85	85	16	18	3	4-18	4-18	
50	150	215	98	160	160	125	125	100	100	16	20	3	4-18	4-18	
65	170	225	108	180	180	145	145	120	120	18	22	3	4-18	8-18	
80	180	235	118	195	195	160	160	135	135	20	22	3	8-18	8-18	
100	190	280	130	215	230	180	190	155	160	20	24	3	8-18	8-23	
125	200	290	148	245	270	210	220	185	188	22	28	3	8-18	8-25	
150	210	310	172	280	300	240	250	210	218	24	30	3	8-23	8-25	
200	230	350	210	335	360	295	310	265	278	26	34	3	12-23	12-25	
250	250	415	240	405	425	355	370	320	332	30	36	3	12-25	12-30	
300	270	450	264	460	485	410	430	375	390	30	40	4	12-25	16-30	
350	290	480	297	520	550	470	490	435	448	34	44	4	16-25	16-34	
400	310	550	324	580	610	525	550	485	505	36	48	4	16-30	16-34	
450	330	585	351	640	660	585	600	545	555	40	50	4	20-30	20-34	
500	350	640	379	705	730	650	660	608	610	44	52	4	20-34	20-41	
600	390	720	434	840	840	770	770	718	718	48	56	5	20-41	24-41	
700	430	780	491	910	955	840	875	788	815	50	60	5	24-41	24-48	
800	470	840	549	1020	1070	950	990	898	930	52	64	5	24-41	24-48	
900	510	990	600	1120	1180	1050	1090	998	1025	54	66	5	28-41	28-54	
1000	550	1050	655	1255	1305	1170	1210	1110	1140	56	68	5	28-48	28-58	
1200	630	1210	770	1485	1525	1390	1420	1325	1350	58	72	5	32-54	32-58	

BUTTERFLY TYPE CUSHION CHECK VALVE

- Butterfly or Short Pattern, Cast Iron or Steel Body,
- Slow Closing equipped with Buffering Device,
- With Small Flow Resistance or Curve,
- Energy Saving, Non slam
- Suitable for Horizontal or Vertical Lines
- Sewage or Water Treatment Applications

Face to Face	DBV Standard
End Flange	ISO, EN or ASME
Ratings	PN10, PN16, PN25

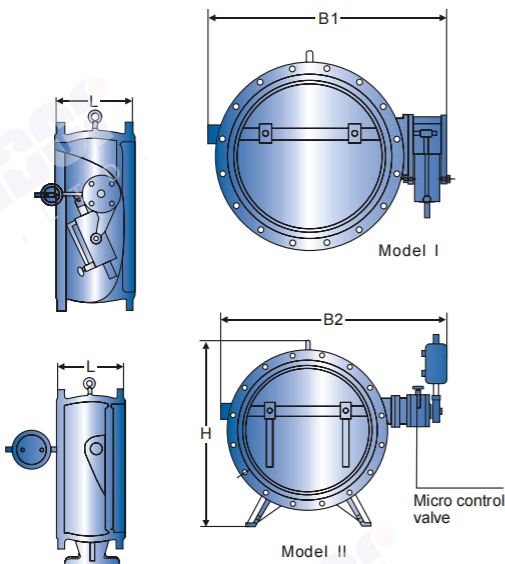

SIZE (DN)	L	H	B1	B2	D			D1		
					PN1.0	PN1.6	PN2.5	PN1.0	PN1.6	PN2.5
Unit: mm										
200	230	550	540	600	335	335	360	295	295	310
250	250	630	600	700	390	405	425	350	355	370
300	270	690	650	740	440	460	485	400	410	430
350	290	780	710	800	500	520	550	460	470	490
400	310	860	770	870	565	580	610	515	525	550
450	330	910	830	920	615	640	660	565	585	600
500	350	980	900	1000	670	705	730	620	650	660
600	390	1070	1090	1250	780	840	840	725	770	770
700	430	1220	1200	1360	895	910	955	840	840	875
800	470	1320	1320	1480	1010	1020	1070	950	950	990
900	510	1430	1420	1580	1110	1120	1180	1050	1050	1090
1000	550	1550	1550	1700	1220	1255	1305	1160	1170	1210
1200	630	1800	1780	1950	1450	1485	1525	1380	1390	1420
1400	710	1980	2000	2175	1675	1685	1750	1590	1590	1640

SIZE (DN)	D2			n- φ d		
	PN1.0	PN1.6	PN2.5	PN1.0	PN1.6	PN2.5
Unit: mm						
200	265	265	278	8-18	12-23	12-25
250	320	320	332	12-18	12-25	12-30
300	368	375	390	12-23	12-25	16-30
350	428	435	448	12-23	16-25	16-34
400	482	485	505	16-23	16-30	16-34
450	532	545	555	16-23	20-30	20-34
500	585	608	610	16-23	20-34	20-41
600	685	718	718	20-25	20-41	24-41
700	800	788	815	24-25	24-41	24-48
800	905	898	930	24-30	24-41	24-48
900	1005	998	1025	24-30	28-41	28-54
1000	1115	1110	1140	28-30	28-48	28-58
1200	1325	1325	1350	32-30	32-54	32-58
1400	1525			36-30		

Ball Valve

DIN BALL VALVE FULL PORT

- Cast or Ductile Iron Split Body, Two Piece Design
- Free Floating or Trunnion Mounted, Full Port
- Fire Safe, Anti-static Device, Blow-out Proof Stem
- Optional Locking Device and ISO 5211 Mounting Pad
- Designed to DIN3357

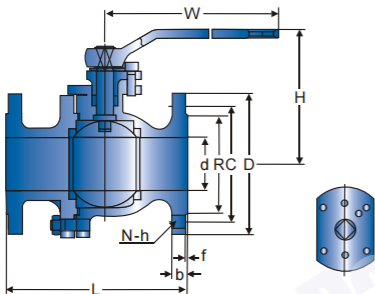

Face to Face	DIN3202 F4/F5
End Flange	DIN2533
Ratings	PN10/16

SIZE (DN)	15	20	25	32	40	50	65	80	100	125	150	200	250
Unit: mm													
d	15	20	25	32	40	50	65	80	100	125	150	200	250
L	115	120	125	130	140	150	170	180	190	325	350	400	450
H	78	113	107	113	130	146	176	222	300	325	350	-	-
W	130	160	160	160	250	250	350	350	400	600	600	-	-
D	95	105	115	140	150	165	185	200	220	250	285	340	405
C	65	75	85	100	110	125	145	160	180	210	240	295	355
R	45	58	68	78	88	102	122	138	158	188	212	268	320
b	14	16	16	18	18	20	20	22	24	26	26	30	32
N-h	4-14	4-14	4-14	4-18	4-18	4-18	4-18	8-18	8-18	8-18	8-23	12-23	12-27
f	2	2	2	2	3	3	3	3	3	3	3	3	3
Φ	42	42	42	50	50	70	102	102	102	125	140	165	165
4-m	M5	M5	M5	M6	M6	M8	M10	M10	M10	M12	M16	M20	M20

DIN BALL VALVE REDUCED BORE

- Cast or Ductile Iron Split Body, Two Piece Design
- Free Floating or Trunnion Mounted, Reduced Bore
- Fire Safe, Anti-static Device, Blow-out Proof Stem
- Optional Locking Device and ISO 5211 Mounting Pad
- Designed to DIN3357

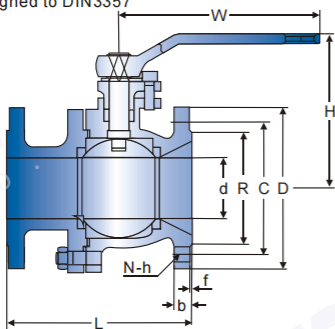

Face to Face	DIN3202 F4/F5
End Flange	DIN2533
Ratings	PN10/16

SIZE (DN)	50	65	80	100	125	150	200
Unit: mm							
d	37	49	58	75	88	98	148
L	150	170	180	190	200	210	230 (F4) 400 (F5)
H	130	145	170	180	205	225	267
W	250	250	350	350	400	400	600
D	165	185	200	220	250	285	340
C	125	145	160	180	210	240	295
R	102	122	138	158	188	212	268
b	20	20	22	24	26	26	30
N-h	4-18	4-18	8-18	8-18	8-18	8-23	12-23
f	3	3	3	3	3	3	3

ANSI BALL VALVE

- Cast or Ductile Iron Split Body, Two Piece Design
- Free Floating or Trunnion Mounted, Full Port
- Fire Safe, Anti-static Device, Blow-out Proof Stem
- Optional Locking Device and ISO 5211 Mounting Pad
- Designed to ANSI B16.1

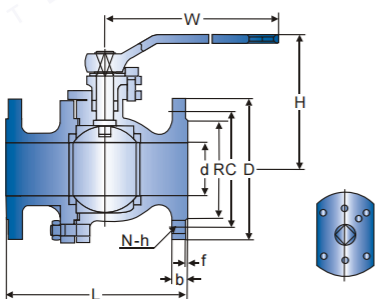

Face to Face	ANSI B16.10
End Flange	ANSI B16.1, CL150
Ratings	ANSI 150

SIZE (in.)	1/2"	3/4"	1"	1-1/4"	1-1/2"	2"	2-1/2"	3"	4"	5"	6"	8"	10"
Unit: mm													
d	15	20	25	32	40	50	65	80	100	125	150	200	250
L	108	117	127	140	165	178	190	203	229	356	394	457	533
H	78	113	107	113	130	146	176	222	222	250	275	-	-
W	130	160	160	160	250	250	350	350	400	600	600	-	-
D	89	98.6	108	117	127	152	178	191	229	254	279	343	406
C	60.5	70	79.5	89	98.5	120.5	139.5	152.5	190.5	216	241.5	298.5	362
R	35	43	51	63.5	73.5	92	104.7	127	157.2	186	216	270	332
b	9.7	10.5	11.2	12.7	14.5	15.9	17.5	19.1	23.9	24	25.4	28.5	30.2
N-h	4-16	4-16	4-16	4-16	4-16	4-19	4-19	4-19	8-19	8-22	8-22	8-22	12-25
f	1.6	1.6	1.6	1.6	1.6	1.6	1.6	1.6	1.6	1.6	1.6	1.6	1.6
Φ	42	42	42	50	50	70	102	102	102	125	140	165	165
4-m	M5	M5	M5	M6	M6	M8	M10	M10	M10	M12	M16	20	20

BS BALL VALVE

- Cast or Ductile Iron Split Body, Two Piece Design
- Free Floating or Trunnion Mounted, Full Port
- Fire Safe, Anti-static Device, Blow-out Proof Stem
- Optional Locking Device and ISO 5211 Mounting Pad
- Designed to BS5159

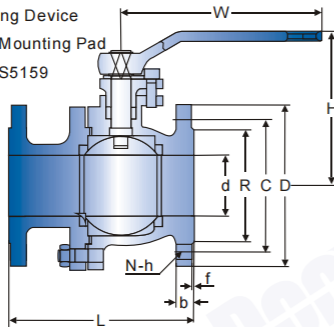

Face to Face	BS4460
End Flange	BS4504
Ratings	PN10/16

SIZE (in.)	1/2"	3/4"	1"	1-1/4"	1-1/2"	2"	2-1/2"	3"	4"	5"	6"	8"
	Unit: mm											
d	15	20	25	32	40	50	65	80	100	125	150	200
L	108	117	127	140	165	203	222	241	305	356	394	457
L2						178	190	203	229			
H	78	113	107	113	130	146	176	222	222	250	275	-
W	130	130	160	160	250	250	350	350	400	400	600	-
D	95	105	115	140	150	165	185	200	220	250	285	340
C	65	75	85	100	110	125	145	160	180	210	240	295
R	45	58	68	78	88	102	122	139	158	188	212	268
b	14	16	16	18	18	20	20	22	24	26	26	300
N-h	4-14	4-14	4-14	4-18	4-18	4-18	4-18	8-18	8-18	8-18	8-18	12-22
f	2	2	2	2	3	3	3	3	3	3	3	3

THREADED BALL VALVE

- Cast or Ductile Iron Body, Investment Casting
- One Piece Uni-body, Free Floating Ball, Full Port, Threaded Ends
- Fire Safe, Anti-static Device, Blow-out Proof Stem
- Optional Locking Device and ISO 5211 Mounting Pad

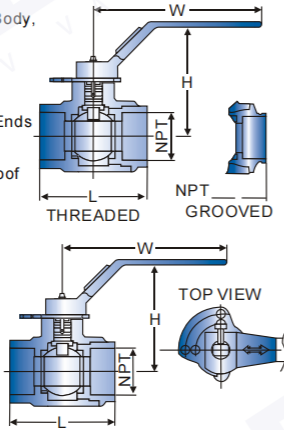

Face to Face	ANSI B16.10
Threaded Ends	ANSI B16.34
Butt Weld Ends	ANSI B16.11, B16.25
Socket Weld Ends	ANSI B1.20.3
Ratings	750-2000WOG

SIZE (in.)	Rating	Φd	L (THREADED)	B (GROOVED)	H	W
	Unit: mm					
1"×1"	2500	25.4	101.6	123.8	79.7	160
2"×1-1/2"	2500	38.1	139.7	152.4	140.8	216
2"×2"	2160	50.8	152.4	158.8	152.1	216
3"×2"	2160	50.8	185.8	185.8	152.1	216
3"×3"	1500	76.2	222.3	222.3	175.0	381
4"×3"	1500	76.2	222.3	222.3	175.0	381
4"×4"	750	103.5	238.2	238.2	200.5	460

SIZE (in.)	Rating	Φd	L	H	W
	Unit: mm				
1"×1"	2500	25.4	101.6	79.7	160
2"×1-1/2"	2500	38.1	139.7	140.8	216
2"×2"	2160	50.8	152.4	152.1	216
3"×2"	2160	50.8	209.4	152.1	216
3"×3"	1500	76.2	222.3	175.0	381
4"×3"	1500	76.2	222.3	175.0	381
4"×4"	750	103.5	238.2	200.5	460

WAFER BALL VALVE

- Investment Casting, One Piece Uni-body,
- Free Floating Ball, Full Port or Reduced Bore, Wafer Ends
- Fire Safe, Anti-static Device, Blow-out Proof Stem
- Designed to DIN3357

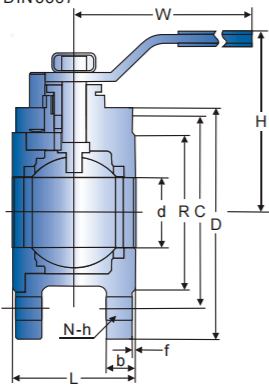

Face to Face	DIN2533 F4
End Flange	DIN2533
Ratings	PN10/16

SIZE (DN)	15	20	25	32	40	50	65	80	100
	Unit: mm								
d	15	20	25	30	38	46	57	75	90
L	40	40	50	55	65	80	100	120	140
H	78	113	107	113	130	140	176	222	300
W	130	130	170	170	220	250	350	350	400
D	95	105	115	140	150	165	185	200	220
C	65	75	85	100	110	125	145	160	180
R	46	58	68	78	88	102	122	138	158
b	14	16	16	18	18	20	20	22	24
N-h	4-M12	4-M12	4-M12	4-M16	4-M16	4-M16	4-M16	4-M16	4-M16
f	2	2	2	2	2	2	3	3	3

Plug Valve

ECENTRIC PLUG VALVE

- Cast or Ductile Iron Body, Round or Rectangular Port, Vee-type Packing
- Welded-in Overlay Seating Surface, Cylindrically Shaped,
- Off-set NBR encapsulated Plug, Integral Plug Shaft,
- Designed to ANSI/AWWAC504, MSSR-SR-108

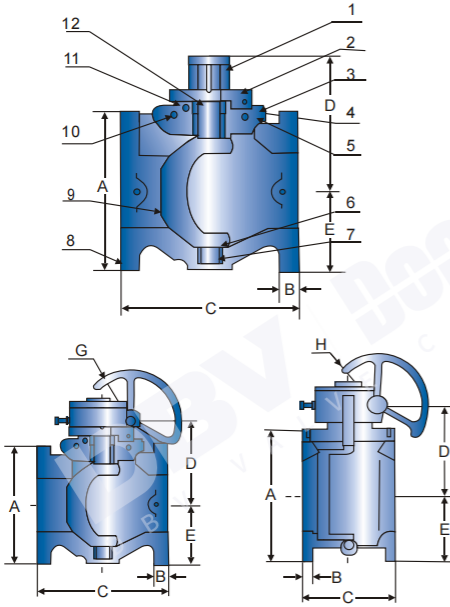

Wall Thickness	AWWAC504-00 Table 2
End Flange	ANSI B16.1 CL125 or CL150
Grooved Ends	AWWAC606 for D.I. or Steel Pipe
Mechanical Joints	AWWAC111 (ANSI 21.11)
Ratings	CL125/CL150/CL250

Flanged End

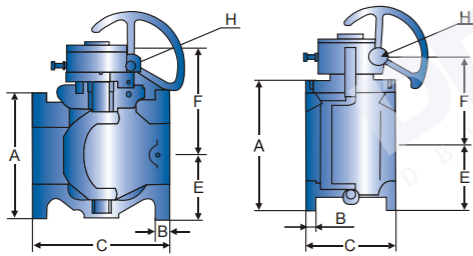

Grooved End

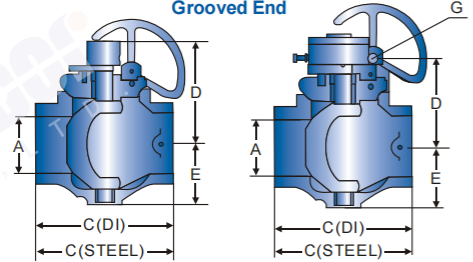

Mechanical Joint END

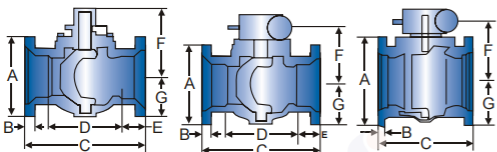

FLANGED END-ANSI 125 SIZE (in.)

	2-1/2"	3"	4"	5"	6"	8"	10"	12"	14"
A	7	7.5	9	10	11	13.5	16	19	21
B	0.68	0.75	0.93	0.93	1	1.12	1.18	1.25	1.38
C	7.5	8	9	10	10.5	11.5	13	14	17
D	6.18	6.18	7.25	8.38	8.38	10.68	—	—	—
E	3.5	3.75	4.5	5.75	5.75	7.62	8.88	10	13
G	6	6	6	6	6	12	12	12	12

Unit: inch

SIZE (in.)

	14"	16"	18"	20"	24"	30"	36"	42"	48"
A	21	23.25	25	27.5	32	38.75	46	53	59.5
B	1.38	1.43	1.56	1.68	1.88	2.12	2.38	2.62	2.75
C	17	17.75	21.5	23.5	42	51	60	72	84
D	15.06	15.81	17	20.43	22.88	27.59	33	37.62	37.62
E	13	14	15	16	21.62	24.75	29	29	36
H	18	18	18	18	24	24	24	30	30

Unit: inch

SUGGESTED MATERIALS LIST

NO.	Name	Material	Specification
1	Torque Collar	Ductile Iron	ASTMA 536
2	Snap Ring	Spring Steel	-
3	Cap screw	Steel	-
4	Bonnet	Cast Iron	ASTMA 126 Class B
5	O - Ring	Elastomer	-
6	Thrust Washer	PTFE	-
7	Journal Bearing	Stainless Steel	ANSI 316
8	Body	Cast Iron	ASTMA 126 Class B
9	Plug Costing	Elastomer	As Specified
10	Travel Stop	Steel	-
11	U-Cup seal	Elastomer	-
12	Plug	Ductile iron	ASTMA 536 Grade 65-45-12

CV VALUE

SIZE (in.)	3"	4"	5"	6"	8"	10"	12"	14"	16"	18"	20"	24"	30"	36"
CV	500	1000	2000	2000	3000	6000	7000	8000	9000	11000	13000	21000	36000	47000

FLANGED END-CLASS 250

SIZE (in.)	2-1/2"	3"	4"	5"	6"	8"	10"	12"	14"	16"	18"	20"	24"	30"	36"
A	7.5	8.25	10	11	12.5	15	17.5	20.5	23	25.5	28	30.5	36	43	50
B	1.06	1.12	1.25	1.38	1.43	1.62	1.88	2	2.12	2.25	2.38	2.5	2.75	3	3.38
C	9.5	11.12	12	15	15.88	16.5	18	19.75	18.5	19.38	23.12	25	42.88	51.88	61
E	3.5	3.75	4.5	5.75	5.75	8.52	8.88	10	13	14	15	16	21.62	24.75	29
F	6	6.09	7.06	8.31	8.31	10.13	13.88	14.75	15.8	15.81	17	20.43	22.88	27.59	33
H	6	6	6	6	6	12	12	12	18	18	18	18	24	24	24

Unit: inch

Note: All above with gear operators as standard

GHOVED END-AWWA606

SIZE (in.)	2-1/2"	3"	4"	5"	6"	8"	10"	12"	14"
A	2.5	3	4	5	6	8	10	12	14
C(DI)	N/A	N/A	10.25	N/A	12.5	14	16.56	18	21.63
C(STEEL)	8.5	8.5	10.13	12.38	12.38	13.88	16.44	18	21.5
D	6.18	6.18	7.25	8.38	8.38	10.88	—	—	—
E	3.5	3.75	4.5	5.75	5.75	7.62	8.88	10	10
F	5.38	5.59	6.31	7.56	7.56	9.63	11.63	13.31	13.31
G	6	6	6	6	6	12	12	12	18

Unit: inch

MECHANICAL JOINT END

SIZE (in.)	3"	4"	6"	8"	10"	12"	14"	16"	18"	20"	24"	30"	36"	42"	48"
A	7.68	9	11.12	13.38	15.62	17.93	20.31	22.56	24.84	27	31.5	39.12	46	53	60
B	0.93	1	1.06	1.12	1.18	1.38	1.31	1.38	1.43	1.5	1.62	1.68	2	2	2
C	11.5	14.25	15.75	17.38	19.38	20.75	24.5	27.25	29.25	31	42	51	60	72	84
D	6.5	9.25	10.75	12.38	14.38	15.75	17.5	-	-	-	-	-	-	-	-
E	2.5	2.5	2.5	2.5	2.5	3.5	-	-	-	-	-	-	-	-	-
F	6.18	7.25	8.38	10.68	—	—	—	15.81	17	20.43	22.88	26.93	33	37.62	37.62
G	3.84	4.5	5.75	7.62	8.88	10	13	14	15	16	21.62	24.75	29	29	36

Unit: inch

Note: 10" & above with gear operators as standard.

DIN Y STRAINER

- Y Pattern, Castor Ductile Iron Body, SS Mesh
- Bolted Cover, Flanged Ends
- Designed to DIN3202 F1

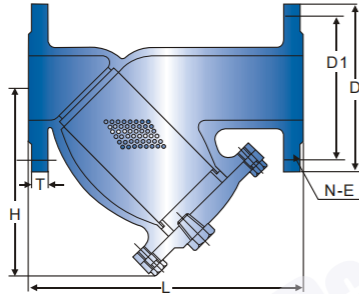

Face to Face	DIN3202 F1
End Flange	DIN2532,2533
Ratings	PN10/16

SIZE (DN)	DIN2532-PN10				DIN2533-PN16				DIN 3202-F1		Unit: mm
	D	D1	N-E	T	D	D1	N-E	T	L	H	
15	95	65	4-14	14	95	65	4-14	14	130	90	
20	105	75	4-14	16	105	75	4-14	16	150	100	
25	115	85	4-14	16	115	85	4-14	16	160	115	
32	140	100	4-18	18	140	100	4-18	18	180	135	
40	150	110	4-18	18	150	110	4-18	18	200	150	
50	165	125	4-18	20	165	125	4-18	20	230	160	
65	185	145	4-18	20	185	145	4-18	20	290	180	
80	200	160	4-18	22	200	160	8-18	22	310	215	
100	220	180	8-18	22	220	180	8-18	24	350	235	
125	250	210	8-18	24	250	210	8-18	26	400	280	
150	285	240	8-23	24	285	240	8-23	26	480	320	
200	340	295	8-23	26	340	295	12-23	30	600	405	
250	395	350	12-23	28	405	355	12-27	32	730	540	
300	445	400	12-23	28	460	410	12-27	32	850	580	
350	505	460	16-23	30	520	470	16-27	36	980	600	
400	565	515	16-27	32	580	525	16-30	38	1100	608	

ANSI Y STRAINER

- Y Pattern, Castor Ductile Iron Body, SS Mesh
- Bolted Cover, Flanged Ends
- Designed to ASME

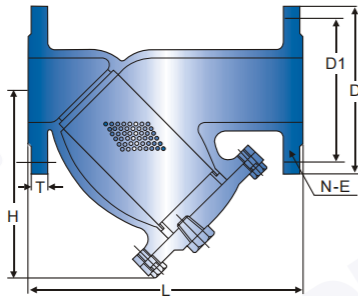

Face to Face	ANSI B16.10
End Flange	ANSI B16.1, B16.5
Ratings	ANSI B16.1 CL125 ANSI B16.5 CL150

SIZE (in.)	ANSI B16.1 CL125				ANSI B16.5 CL150				ANSI B16.1		Unit: mm
	D	D1	N-E	T	D	D1	N-E	T	L	H	
1/2"	-	-	-	-	89	60	4-16	11	108	90	
3/4"	-	-	-	-	99	70	4-16	13	117	100	
1"	108	79.5	4-16	11	108	79.5	4-16	14	127	115	
1-1/4"	117	89	4-16	13	117	89	4-16	16	140	135	
1-1/2"	127	98.5	4-16	14	127	98.5	4-16	18	165	150	
2"	152	120.5	4-19	16	152	120.5	4-19	19	178	160	
2-1/2"	178	139.5	4-19	18	178	139.5	4-19	22	190	180	
3"	191	152.5	4-19	19	191	152.5	4-19	24	203	215	
4"	229	190.5	8-19	24	229	190.5	8-19	24	229	235	
5"	254	216	8-22	24	254	216	8-22	24	356	280	
6"	279	241.5	8-22	25	279	241.5	8-22	25	394	320	
8"	343	298.5	8-22	29	343	298.5	8-22	29	457	405	
10"	406	362	12-25	30	406	362	12-25	30	533	540	
12"	483	432	12-25	32	483	432	12-25	32	610	580	
14"	533	476	12-29	35	533	476	12-29	35	686	600	
16"	597	539.5	16-19	37	597	539.5	16-29	37	762	608	



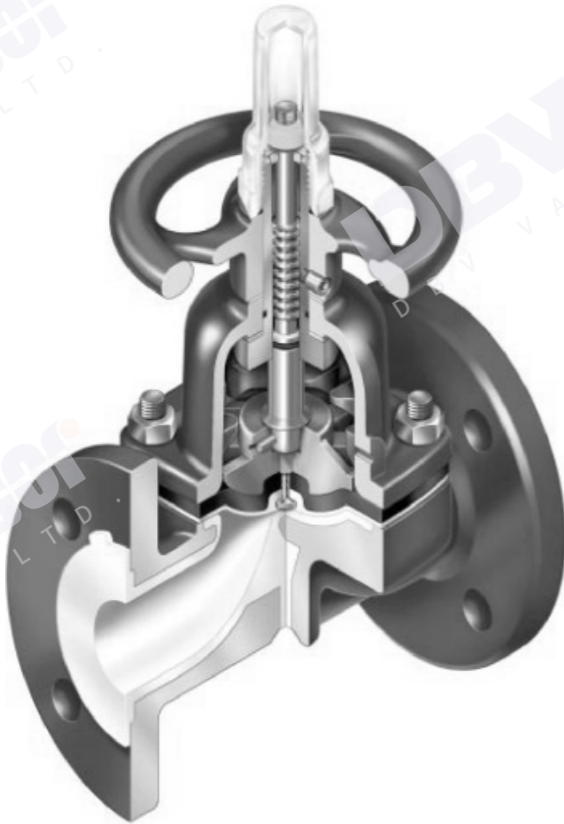
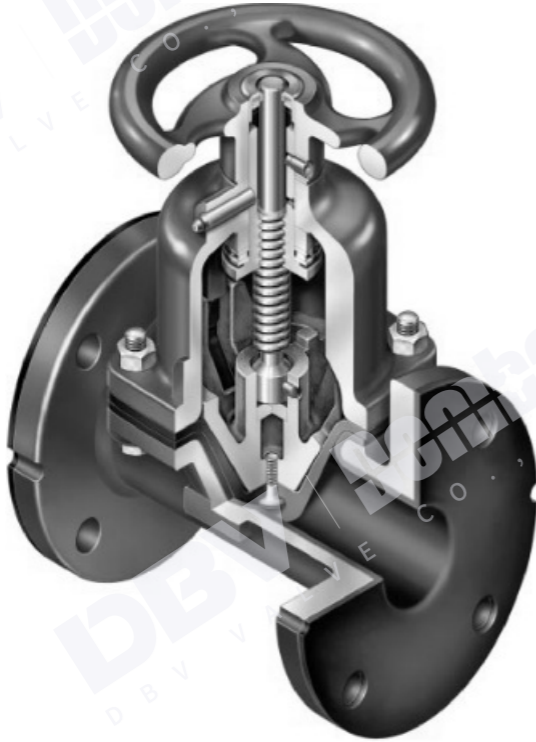

FEATURES AND BENEFITS

The DBV Diaphragm Valve is typically one of the most economical valve solutions in chemical applications due to the wide choice of wetted materials.

BROAD MATERIAL AVAILABILITY

Given the various body and diaphragm materials, the DBV Diaphragm Valve often provides the most economical solution for your process system.

SLURRY APPLICATIONS

Due to the streamlined flow path and virtual absence of cavities, the diaphragm valve is ideal for slurry applications. Cavities within valves tend to entrap solids, either increasing the valve's operational torque or inhibiting operation. The DBV Weir Diaphragm Valve is recommended for slurries containing 15% or less solids. For slurries exceeding 15% solids, the DBV Straightway Diaphragm Valve is recommended.

HIGH PURITY APPLICATIONS

The DBV Diaphragm Valve is the proven selection to minimize particle generation and product entrapment inherent to other valve types.

CORROSIVE APPLICATIONS

A broad selection of plastic linings and PTFE diaphragms, coupled with our corrosion resistant coatings, provide an excellent barrier to chemical attack and corrosion.

BUBBLE TIGHT SHUT-OFF

DBV Weir Diaphragm Valves provide bubble tight shut-off from 0.1 micron to 200psi line in accordance with MSS SP-88 (Manufacturers Standardization Society of the Valves and Fittings Industry, Inc. Standard Practice-Diaphragm Type Valves).

BONNET ISOLATION

Working parts are isolated from the process fluid.

SECONDARY CONTAINMENT

The optional sealed bonnet provides a secondary containment boundary in the case of diaphragm failure; preventing the process media from entering the atmosphere.

UNIQUE FEATURES

Unique features which optimize the valve performance and life, varying by valve size are: adjustable travel stop, protective stem cap, o-ring sealed stem, bronze bushing, position indicator, molded closed diaphragms, and PVDF corrosion resistant coating.

VACUUM APPLICATIONS

The diaphragm valve is capable of bubble tight shut-off down to 0.1 micron. Elastomer or Teflon PTFE diaphragms may be used. The in-leakage rate is less than 1×10^{-6} cc-atm/sec for elastomer diaphragms and can be less upon request.

AVAILABILITY

Body Pattern
Weir Body
Straight Body

Standards Compliance
DIN3202
BS5156
MSS SP-88

Ends Connections
Flanged Ends
Welded Ends
Threaded Ends
Other Options Upon Request

SEAT & SHELL TEST CRITERIA AS STATED IN MSS SP-88

TEST DURATIONS AND TEST PRESSURES BASED ON DIAPHRAGM MAXIMUM SERVICE PRESSURE RATINGS

SIZE (in.)	Maximum Pressure Rating psi (bar)	Shell Test Pressure psi (bar)	Minimum Duration of Shell Test Minutes(1)	Seat Test Pressure psi (bar)	Minimum Duration of Seal Test Minutes(1)
1/2-1	200 (13.8)	240 (16.5)	1/4	200 (13.8)	1/4
1-1/2 -2	175 (12.1)	210 (14.5)	1/4	175 (12.1)	1/4
2-1/2-4	150 (10.3)	180 (12.4)	1	150 (10.3)	1/2
5-6	125 (8.6)	150 (10.3)	1	125 (8.6)	1/2
8	100 (6.9)	120 (8.3)	1	100 (6.9)	1/2
10-12	65 (4.5)	80 (5.5)	3	65 (4.5)	1/2

(1) The minimum duration is the period of inspection after the valve is fully prepared and under full test pressure.

BODY MATERIALS AVAILABLE

WEIR BODIES

Body Type	Material	Identification*	Maximum Temperature**		
			°F	°C	
Metal	Iron	CI or GXXX	350	107	
	Ductile Iron	DI or DXXX	350	177	
	Carbon Steel	WCB or LCB	350	177	
	Bronze	B61 or B62	350	177	
	Stainless	CF8M	350	177	
	Steel 316				
	CN7M	CN7M	350	177	
	Monel	M35	350	177	
Plastic Lined	Hastelloy	CWXM	350	177	
	PP	Blue	200	93	
	PVC	Grey	140	60	
	Saran	Black	175	80	
	PVDF	White with tab	285	140	
	PTFE	White	300	149	
	Rubber Lined	Soft Natural	#5	180	82
		Neoprene	#7	200	93
Hypalon CSM		#9	200	93	
Hard Natural		#10	200	93	
Soft Gum		#11	140	60	
Rubber					
Glass Lined	Graphite Loaded Natural	#12	200	93	
	Butyl	#16	200	93	
	Borosilicate Glass	Blue glass	350	177	

STRAIGHTWAY BODIES

Body Type	Material	Identification*	Maximum Temperature**	
			°F	°C
Metal	Iron	CI or GXXX	225	107
	Carbon Steel	WCB	225	107
	Stainless	CF8M	225	107
Plastic lined	Steel 316			
	PP	Blue	200	93
Rubber lined	Tefzel ETFE	White	225	107
	Soft Natural	#5	180	82
	Neoprene	#7	200	93
	Hypalon CSM	#9	200	93
	Hard Natural	#10	200	93
	Butyl	#16	200	93
Glass lined	Borosilicate Glass	Blue glass	225	107

*X designates a numerical value

**Temperature may decrease dependent on media, pressure and valve size.

RECOMMENDED GUIDELINES

WEIR VALVES

Maximum Velocity ≤ 25 fps for media with no suspended solids

Maximum Velocity ≤ 10 fps for media with 1-15% solids

Maximum Valve $\Delta P \leq 25\%$ Pinlet for throttling

Maximum Solids $\leq 15\%$

These guidelines are recommended to optimize performance and may vary dependent on exact media and conditions. The intent is to help prevent cavitation, choke flow and premature lining and diaphragm wear.

STRAIGHTWAY VALVES

Maximum Velocity ≤ 25 fps for media with no suspended solids

Maximum Velocity ≤ 15 fps for media 1-15% solids

Maximum Velocity ≤ 10 fps for media with solids $> 15\%$

Maximum Solids $\leq 50\%$

These guidelines are recommended to optimize performance and may vary dependent on exact media and conditions. The intent is to help prevent cavitation, choke flow and premature lining and diaphragm wear.

BODY LINING MATERIALS INSTRUCTION

Material	Code	Suitable temperature	Applicable medium
*Fluorinated ethylene propylene	FEP、F46	≤150℃	Different density hydrochloric acid, sulfuric acid, hydrofluoric acid, aqua regia, nitric acid, all kinds of organic acid, alkali, acid, aqua regia, nitric acid and weak acid, alternation of acid and alkali many kinds of organic solvent and other strong corrosive media except for melt alkali metals, element fluorin and aromatic hydrocarbon.
Poly chlorotrifluoroethylene	PCTFE、F3	≤120℃	General corrosive, media except for hydrofluoric acid, strong phosphoric acid and strong alkali
Polyvinylidene fluoride	PVDF、F2	≤120℃	Most of organic acids, mineral acids and inorganic solvents except for strong nitric acid, oleum, chloride sulfonic acid and strong oxidant.
Ethylene tetrafluoroethylene	TFE/E、F40	≤120℃	The product adapts to transport current medium, for example corrosive gas, liquid as well as solid and liquid slurry. It has good corrosion acid, alkali and salt solution. It has the features of static resistance, innocuity.
Tefzel			
Perfluoroalkoxy	PFA	≤180℃	Noncorrosive medium
Acid-resistant enamel		≤100℃	Usual corrosive medium
Reinforced polypropylene	RPP	≤100℃	
Polyolefin	PO	≤100℃	
Cast iron unlined		≤100℃	
Stainless steel, unlined		≤150℃	

BODY LINING MATERIALS INSTRUCTION

Material	Code	Suitable temperature	Applicable medium
Fluorinated ethylene propylene	FEP	≤120℃	Different density sulfuric acid, hydrofluoric acid, aqua regia, high-temperature strong nitric acid, all kinds of organic acid, strong oxidant, alternation of strong acid and weak acid, alternation of acid and alkali, many kinds of organic solvent ect.
Perfluoroalkoxy	PFA	≤150℃	Also have the good features of corrosion resistance, heat and electric resistance, viscosity resistance, viscosity resistance and low frictional coefficient.
Teflon	PTFE	≤180℃	

Note: *Marked is DBV standard construction

Temperature shown in above table is only for reference, while the temperature maybe depends on different work conditions. Consult factory for any further details.



MATERIALS INSTRUCTION

Material	Code	Suitable temperature	Applicable medium
Isobutylene-isoprene rubber	IIR	≤120℃	Except for >75% sulfuric acid, >20% hydrochloric acid, <60% hydrofluoric acid, >85% phosphoric acid, corrosive alkali and ester.
Natural rubber	NR	≤85℃	Purified water, mineral salt and diluent mineral acid ect
Ethylene-propylene -dinen meyhylene Vistalon	EPDM	≤120℃	Have the acid resistance and alkali resistance like the natural rubber and be suitable for application in the low-pressure steam, hot water and cold water.
Chloroprene rubber	CR	≤85℃	Acid-resistant and alkali-resistant and the non-polar solvent and the abrasion resistance are better than the natural rubber.
Nitrile, Buna-N	NBR	≤85℃	Oil-resistant and abrasion resistant and the acid resistance is the same as the natural rubber.
Hypalon	CSPE	≤120℃	The product has the features of ozone resistant, atmospheric aging resistance, acid and alkali resistance, oxidant and many kinds of chemical medicine resistance, and burning resistance, heat resistance but no resistance to petroleum and arene.
Fluoroelastomer Viton	FKM	≤150℃	Have the corrosive resistance like the fluoroelastomer. Be very stable in the strong acid and strong oxidant and be stable in the organic solvent and alkali solvent
Silicone rubber	SI	≤200℃	Be heatproof, excellent electricity insulation capability and wear-able; may resist corrosion of dilute acid, dilute alkali, salt and water, can't resist corrosion of petrolic products such as gasoline coal oil etc.

Note: *Marked is DBV standard construction

Temperature shown in above table is only for reference, while the temperature maybe depends on different work conditions. Consult factory for any further details.

Cv VALUES STRAIGHTWAY VALVE CV RATINGS (100% OPEN)

ITEM	1/2	1	1-1/2	2	2-1/2	3	4	6	8	10	12
Flanged Unlined	11	60	115	275	450	525	700	2250	4250	5000	5000
Flanged Plastic Lined		24	80	209		370	569	1400	2644**		
Flanged Hard Rubber Lined		55	130	260	365	460	700	1800	3500	4850	4850
Flanged Soft Rubber Lined		42	79	220	365	460	700	1800	3500	4850	4850
Flanged Glass Lined		48	100	270	425	475	700	1950	4400		
Screwed End	15	39	120	265							

Note: Flanged Soft Rubber = soft natural rubber, Neoprene, Hypalon and Butyl linings.

Flanged Hard Rubber = hard natural rubber lining.

Note: Data is based on estimates.

Cv VALUES WEIR VALVE CV RATINGS (100% OPEN)

ITEM	1/2	3/4	1	1-1/4	1-1/2	2	2-1/2	3	4	6	8	10	12
Flanged Unlined	5.5	22	22	56	56	70	160	190	310	600	1200	1800	2550
Flanged Plastic Lined	-	10	10	38	38	67	100	175	285	690	1070	-	-
Flanged Hard Rubber Lined	4.0	10	10	31	31	55	115	160	260	625	1150	1750	2350
Flanged soft Rubber Lined	2.0	7.0	7.0	25	25	50	110	155	250	515	1150	1750	2350
Flanged Glass Lined	5.5	22	22	53	53	78	180	250	420	850	1700	-	-
Screwed End	4.4	10	19	48	48	70	95	172	-	-	-	-	-
Butt Weld	3.5	7.5	18.6	-	48	70	95	180	400	600*	1200*	-	-

Note: *Data is based on estimates

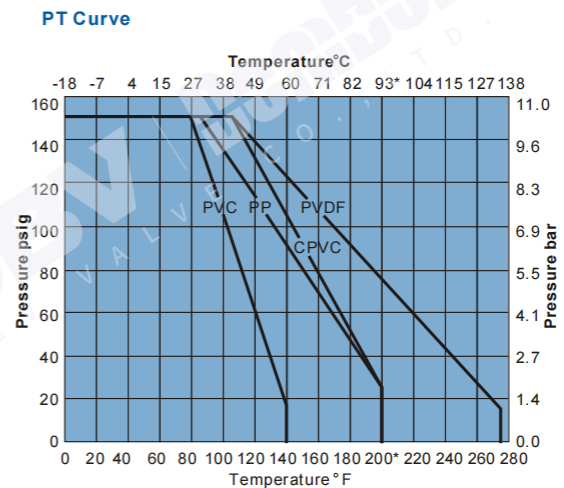
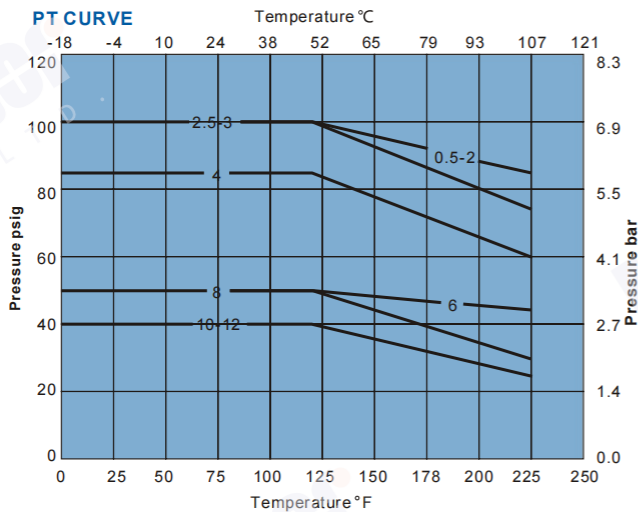

Diaphragm Valve

INSTRUCTION OF DIAPHRAGM VALVE FACE TO FACE AVAILABLE

The length of valve body structure and the dimension of flange connection can be manufactured according to the following table or according to the requirements of customers.

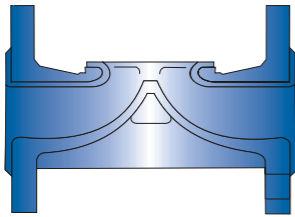

BS LONG PATTERN

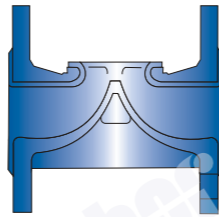

BS SHORT PATTERN

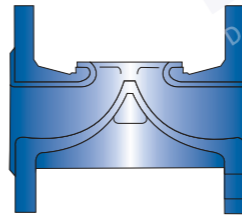

DIN PATTERN

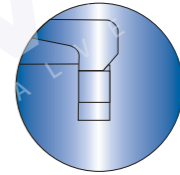

BS UNLINED

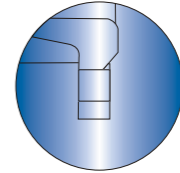

DIN UNLINED

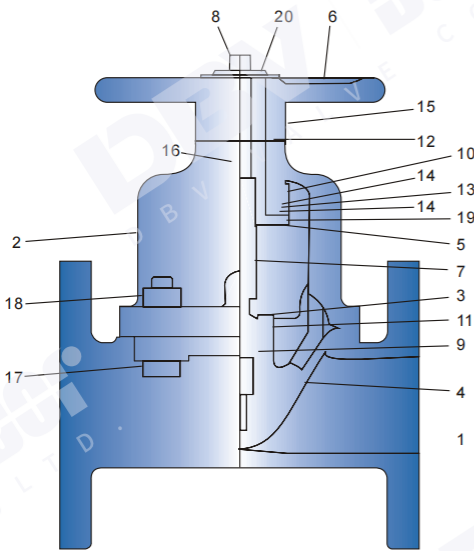

MATERIALS

PARTS

Item	Description	Material
1	Body Flanged	Cast Iron
2	Bonnet	Cast Iron
3	Compressor	Cast iron
4	Diaphragm	Elastomer
5	Bushing	Brass
6	Handwheel	Cast Iron
7	Spindle	Steel
8	Spindle, Extension (indicating)	Stainless Steel
9	Insert	Steel
10	Spacer	Steel
11	Pin, Spirol	Stainless Steel
12	Washer, Shim	Polyethylene
13	Bearing, Thrust Needle	Steel
14	Bearing, Thrust Race	Steel
15	Screw, Set Hex. Soc.	Steel
16	Fitting, Tube	Steel
17	Screw, Hex, Ho, Cp	Steel
18	Nut, Hex.	Steel
19	Pin, Spirol	Stainless Steel
20	Capseal	Brass

WEIR PATTERN DIAPHRAGM VALVE

- Weir Pattern, Un-lined or Fully Lined Body
- Elastomer or PTFE Coated Compressor
- Epoxy Coating Inside and Outside
- Bubble-tight Shut-off, Secondary Containment
- Designed to BS5156

Face to Face	BS5156
End Flange	BS4504
Ratings	PN10/16

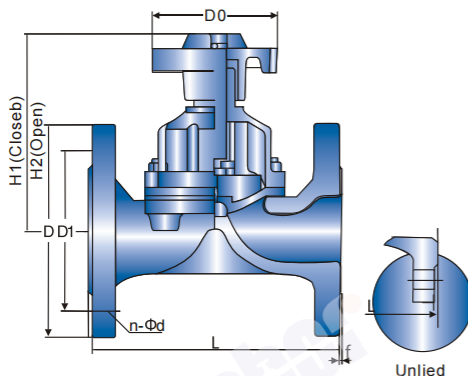

SIZE (DN)	Nominal pressure MPa	Working pressure MPa	L	D	D1	n-Φd	f	H1	H2	D0	W.T (kg)
15	1.6	1.6	108	95	65	4-14	2	90	99	66	2
20			117	105	75	4-14	2	93	103	66	3
25			127	115	85	4-14	2	100	112	66	4
32			146	140	100	4-18	2	127	144	96	6.5
40			159	150	110	4-18	2	136	156	96	7.5
50	1.0	1.0	190	165	125	4-18	2	151	177	118	10
65			216	185	145	4-18	2	183	213	165	16
80			254	200	160	8-18	2	198	273	230	23.5
100			305	220	180	8-18	2	266	320	280	34
125			356	250	210	8-18	3	319	386	280	44
150			406	285	240	8-22	3	380	453	368	67.5
200			521	340	295	8-22	3	506	626	400	141.5
250			635	395	350	12-22	5	598	734	500	229
300			749	445	400	12-22	5	698	778	560	321
350			787	505	460	16-22	5	723	883	560	360
400	914	565	515	16-26	5	868	1078	640	584		

PNEUMATIC FAIL CLOSED DIAPHRAGM VALVE

- Weir Pattern, Pneumatic Fail Closed
- Un-lined or Fully Lined Body
- Elastomer or PTFE Coated Compressor
- Epoxy Coating Internally and Externally
- Bubble-tight Shut-off, Secondary Containment
- Designed to BS5156

Face to Face	BS5156
End Flange	BS4504
Ratings	PN10/16

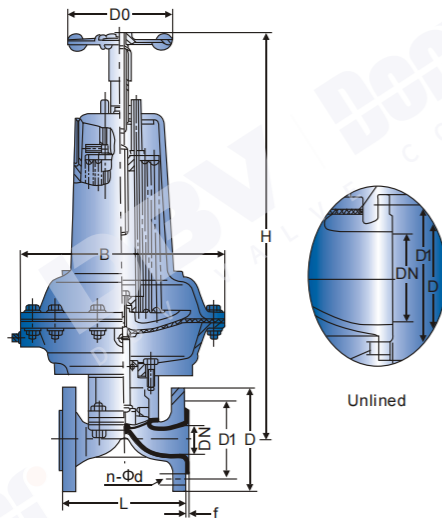

SIZE (DN)	Nominal pressure MPa	Working pressure MPa	L	D	D1	n-Φd	f	H
Unit: mm								
15	1.6	1.6	108	95	65	4-13.5	2	
20			117	105	75	4-13.5	2	
25			127	115	85	4-17.5	2	394
32			146	140	100	4-17.5	2	400
40			159	150	110	4-17.5	2	485
50			190	165	125	4-17.5	2	635
65	1.0	1.0	216	185	145	8-17.5	2	650
80			254	200	160	8-17.5	2	660
100			305	220	180	8-17.5	2	816
125		0.6	356	250	210	8-22	3	825
150			406	285	240	8-22	3	1013
200		0.4	521	340	295		3	1300

SIZE (DN)	D0	B	Code ES	Air pressure Mpa	Air joint in	Air consumption cm ³	W.T (kg)
Unit: mm							
15							
20	120	168	61	0.3	1/8	163.89	7.2
25	120	168	61	0.3~0.4	1/8	196.65	8.9
32	120	168	61	0.3~0.4	1/8	229.4	10.6
40	165	260	62	0.3~0.4	1/4	1425.7	19.5
50	165	318	63	0.3~0.4	1/4	2284.1	34.9
65	165	318	63	0.3~0.4	1/4	3048	39.9
80	165	318	63	0.4~0.5	1/4	3244.7	51.9
100	280	425	64	0.4~0.5	3/8	6964.5	93.2
125	280	425	64	0.4~0.5	3/8	7439.7	105.3
150	310	549	65	0.5	3/8	14912	184.5
200	483	749	66	0.6	1/2	49161	407.4

PNEUMATIC FAIL OPENED DIAPHRAGM VALVE

- Weir Pattern, Pneumatic Fail Opened
- Un-lined or Fully Lined Body
- Elastomer or PTFE Coated Compressor
- Epoxy Coating Internally and Externally
- Bubble-tight Shut-off, Secondary Containment
- Designed to BS5156

Face to Face	BS5156
End Flange	BS4504
Ratings	PN10/16

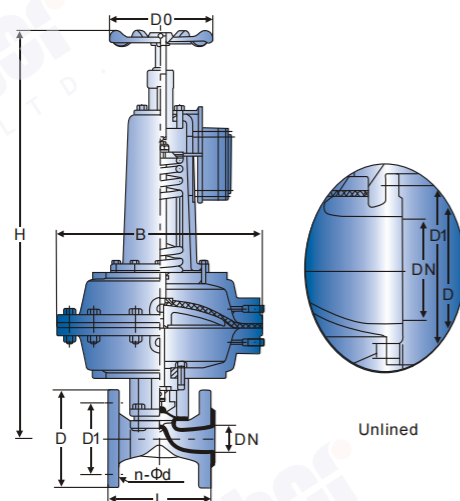

SIZE (DN)	Nominal pressure MPa	Working pressure MPa	L	D	D1	n-Φd	f	H
Unit: mm								
15	1.6	1.6	108	95	65	4-13.5	2	343
20			117	105	75	4-13.5	2	345
25			127	115	85	4-17.5	2	363
32			146	140	100	4-17.5	2	430
40			159	150	110	4-17.5	2	575
50			190	165	125	4-17.5	2	588
65	1.0	1.0	216	185	145	8-17.5	2	769
80			254	200	160	8-17.5	2	816
100			305	220	180	8-17.5	2	820
125	1.0	0.6	356	250	210	8-22	3	920
150			406	285	240	8-22	3	1010
200	1.0	0.4	521	340	295	12-22	3	
250			635	395	350		5	

SIZE (IN)	D0	B	Code ES	Air pressure Mpa	Air joint in	Air consumption cm ³	W.T (kg)
Unit: mm							
15							
20	140	168	68	0.3	1/8	163.87	6.3
25	140	168	68	0.3~0.4	1/8	196.65	7.3
32	140	260	68	0.3~0.4	1/8	229.4	8.3
40	140	260	69	0.3~0.4	1/4	1458.7	14.3
50	140	260	70	0.3~0.4	1/4	3162.7	26
65	140	260	70	0.3~0.4	1/4	3243	30.8
80	165	425	71	0.4~0.5	3/8	6636.8	64.9
100	280	425	71	0.4~0.5	3/8	6948	70.3
125	280	425	71	0.4~0.5	3/8	7374.2	80.7
150	280	549	72	0.5	3/8	10652	131.2
200	280	549	72	0.6	3/8	16715	212
250							

Diaphragm Valve

PNEUMATIC RECIPROCAL DIAPHRAGM VALVE WITH MANUAL

- Weir Pattern, Pneumatic Reciprocal Type
- Un-lined or Fully Lined Body
- Elastomer or PTFE Coated Compressor
- Epoxy Coating Internally and Externally
- Bubble-tight Shut-off, Secondary Containment
- Designed to BS5156

Face to Face	BS5156
End Flange	BS4504
Ratings	PN10/16

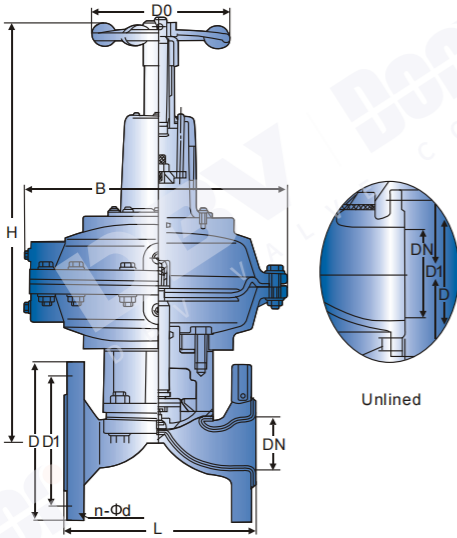

SIZE (DN)	Nominal pressure MPa	Working pressure MPa	L	D	D1	n-Φd	f	H
15	1.6	1.6	108	95	65			
20			117	105	75	4-13.5	2	343
25			127	115	85	4-13.5	2	345
32			146	140	100	4-17.5	2	363
40			159	150	110	4-17.5	2	430
50			190	165	125	4-17.5	2	575
65	1.0	1.0	216	185	145	4-17.5	2	588
80			254	200	160	8-17.5	2	769
100			305	220	180	8-17.5	2	816
125			356	250	210	8-17.5	3	820
150			406	285	240	8-22	3	920
200	1.0	0.6	521	340	295	8-22	3	1010
250			635	395	350		5	

Unit: mm

SIZE (DN)	D0	B	Code ES	Air pressure Mpa	Air joint in	Air consumption cm ³	W.T (kg)
15							
20	140	168	54	0.3	1/8	163.87	5.6
25	140	168	54	0.3~0.4	1/8	196.65	6.8
32	140	260	55	0.3~0.4	1/8	229.4	7.7
40	140	260	55	0.3~0.4	1/4	1458.7	13.9
50	140	260	55	0.3~0.4	1/4	3162.7	24.5
65	140	260	55	0.3~0.4	1/4	3243	29
80	165	425	56	0.4~0.5	3/8	6636.8	63
100	280	425	57	0.4~0.5	3/8	6948	66
125	280	425	57	0.4~0.5	3/8	7374.2	75
150	280	549	58	0.5	3/8	10652	125
200	280	549	58	0.6	3/8	16715	206
250							

Unit: mm

STRAIGHT THROUGH DIAPHRAGM VALVE

- Straight Through
- Un-lined or Fully Lined Body
- Elastomer or PTFE Coated Compressor
- Epoxy Coating Internally and Externally
- Bubble-tight Shut-off, Secondary Containment
- Designed to BS5156

Face to Face	BS5156
End Flange	BS4504
Ratings	PN10/16

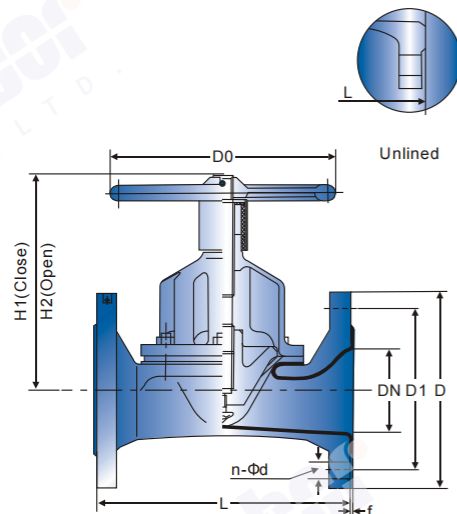

SIZE (DN)	Nominal pressure MPa	Working pressure MPa	L	D	D1	n-Φd	f	H1	H2	D0	W.T (kg)
20	1.0	1.0	117	105	75	4-14	2	150	162		
25			127	115	85	4-14	2	150	162	120	3.5
32			146	140	100	4-18	2	152	180	120	5
40			159	150	110	4-18	2	152	180	120	6
50			190	165	125	4-18	2	163	198	120	8.5
65			216	185	145	4-18	2	205	227	230	16
80			254	200	160	8-18	2	220	252	230	22
100			305	220	180	8-18	2	262	300	280	32
125	1.0	0.6	356	250	210	8-18	3	290	335	280	43.5
150			406	285	240	8-22	3	368	427	368	65
200			521	340	295	8-22	3	410	470	483	112.5
250	1.0	0.4	635	395	350	12-22	5	479	569	483	192.5
300			749	445	400	12-22	5	550	650	560	296
350			787	505	460	16-22	5	550	650	560	
400	1.0	0.25	914	565	515	16-26	5			640	

Unit: mm

VACUUM DIAPHRAGM VALVE

- Straight Through
- Threaded or Weld Ends
- Bubble-tight Shut-off
- Designed to BS5156

Face to Face	DBV Standard
Flanged Ends	BS4504
Lap Joints Ends	DBV Standard
Ratings	PN10

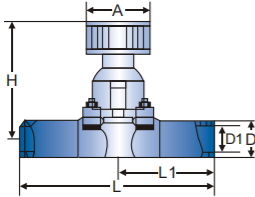

Figure 1

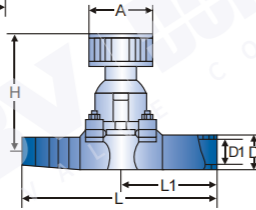

Figure 2

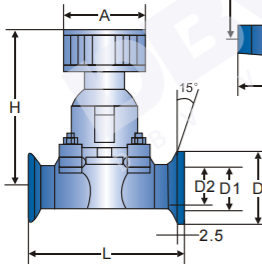

Figure 3

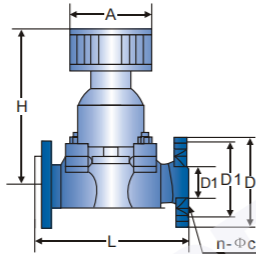
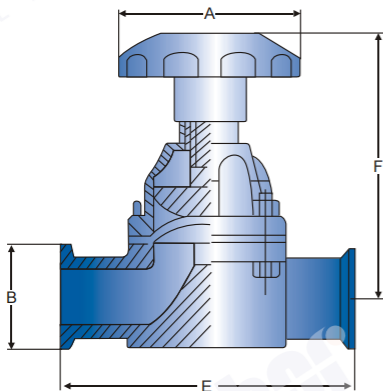

Figure 4

SANITARY DIAPHRAGM VALVE

- Straight Through
- Threaded or Weld Ends
- Bubble-tight Shut-off
- Designed to BS5156

Face to Face	DBV Standard
End Flange	BS4504
Ratings	PN10



CONNECTING PIPE WELDED END FIGURE 1

Model	DN	D	H	A	L	L1
Unit: mm						
GM-10C-H (I)	10	19	80	55	240	120
GM-25C-H (I)	25	32	105	80	240	120
GM-40C-H	40	45	133	100	240	120
GM-50C-H	50	57	157	100	240	120
GM-10D-H (I)	10	19	77.5	50	150	150
GM-25D-H (I)	25	32	105	60	75	75

CONNECTING PIPE WELDED END FIGURE 2

Model	DN	D	H	A	L	L1
Unit: mm						
GM-10C-H (II)	10	19	80	55	195	120
GM-25C-H (II)	25	32	105	80	236	120
GM-10D-H (II)	10	19	77.5	50	150	75
GM-25D-H (II)	25	32	105	66	175	75

QUICK UNLOAD FLANGED END FIGURE 3

Model	DN	D	D1	H	A	L
Unit: mm						
GM-10C-KF	10	30	12.2	80	55	75
GM-25C-KF	25	40	26.2	105	80	120
GM-10C-KF	40	50	41.2	133	100	120

LAP JOINT FLANGED END FIGURE 4

Model	DN	D	D1	H	A	L	n-Φc
Unit: mm							
GM-10C	10	46	36	80	55	75	4-Φ6
GM-25C	25	70	55	105	80	120	4-Φ7
GM-40C	40	100	80	133	100	150	4-Φ9
GM-50C	50	110	90	157	100	180	4-Φ9

SIZE (DN)	A	B	E	F
Unit: mm				
15	108	34	80	89/99
20	118	50.5	80	91/102
25	127	50.5	80	110/123
32	146	50.5	80	129/138
40	159	50.5	120	139/159
50	191	64	120	159/186

Diaphragm Valve

THREADED DIAPHRAGM VALVE

- Weir Pattern
- Female Threaded Ends
- Bubble-tight Shut-off
- Designed to BS5156

Face to Face	DBV Standard
End Flange	BS4504
Threaded Ends	BS EN10241
Ratings	PN10/16

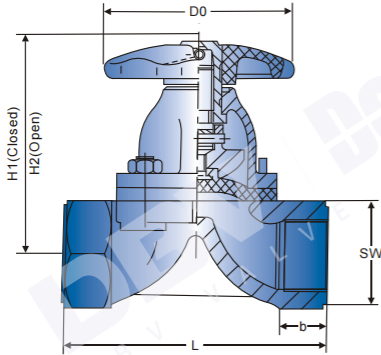

SIZE (DN)	Nominal pressure	Working pressure MPa	L	SW	b	H1	H2	D0	W.T (kg)
8	1.6	1.6	50	20		60	66	45	0.6
10			50	24				45	0.7
15			65	38	8	84	92	50	0.8
20			85	40	12	93	103	50	1.1
25			110	48	18	106	120	66	1.9
32			120	58	18	137	156	96	3.3
40			140	69	18	142	163	96	4.2
50			165	82	20	167	192	96	5.8
65	1.6	1.0	203	90	30	190	225	165	9.5
80			254	105	32	206	246	230	16.2

Unit: mm

PINCH VALVE

- Straight Through Flow
- Bolted Cover, Flanged Ends
- Fully Body Elastomer Rubber Lined
- Designed to ISO Standard

Face to Face	DBV Standard
End Flange	EN Standard
Ratings	PN6/10/16

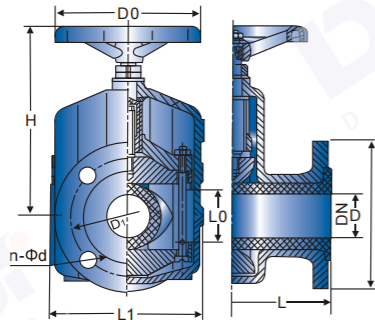

MANUAL

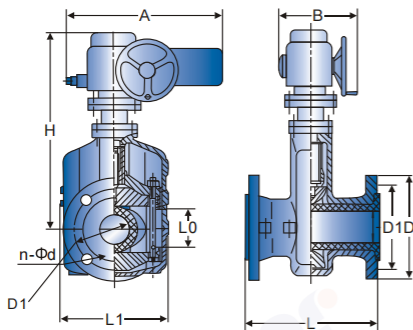

ELECTRIC

MANUAL

DN	Nominal pressure Mpa	Working pressure MPa	L	L1	L0	D	D1	n-φd	D0	H	W.T (kg)
25	0.6	0.6	160	124	31	115	85	4-14	120	137	3
32			165	145	40	140	100	4-18	140	174	4.5
40			190	157	50	150	110	4-18	140	186	5.5
50			210	160	60	160	125	4-18	160	205	7.5
65			270	199	74	180	145	4-18	160	238	10.5
80			300	222	88	195	160	4-18	200	241	15.5
100			350	250	106	215	180	8-18	240	301	20
125			430	318	134	245	210	8-18	280	360	32.5
150			500	350	158	280	240	8-23	320	348	48
200	0.6	0.4	650	446	206	335	295	8-23	560	430	85
250			800	516	256	395	350	12-23	560	540	
300			950	562	304	445	400	12-23	620	741	
350			1100			500	460	16-23			

Unit: mm

ELECTRIC

DN	H	A	B	D0	Kw	W.T (kg)
25		443	133		0.12	3
32						4.5
40						5.5
50		552	425	305	0.25	7.5
65		552	425	305	0.37	10.5
80		552	425	305	0.75	15.5
100		552	425	305	0.75	20
125						32.5
150	1000					48
200	1174	766	390	305	1.1	102
250						
300						
350						

Unit: mm

HYDRAULIC CONTROL VALVES

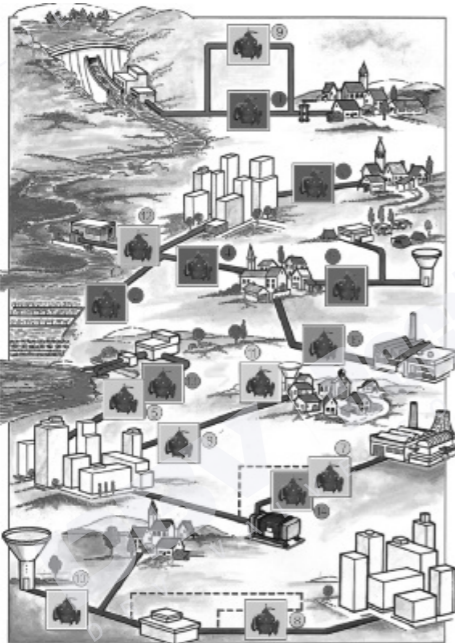

FEATURE AND APPLICATION

- Can reduce the pressure of the water supply from higher relative position.
- When the water flows out from the booster pump of higher pressure, the pressure will be reduced and the water will flow into the nozzle of the irrigation system.
- Reduce the valve hind pressure and keep it at the setting state.
- When the outflow volume is larger, the pressure is reduced to the low-pressure protective scale.
- When the water demand of the system is over the dipping off the pump, the borehole pump and the booster pump can be protected.
- When the water is supplied from the high-pressure zone to the low-pressure zone, it can be avoided that the high pressure zone dips the water in excess.
- Prevent the pressure from the exit of the pump being lower than the lowest safe pressure.
- Protect the differential pressure of the pump front and pump hind in order to reach the constant flow.
- Protect the water supply system from the sporadic overbig pressure in the transportation. (caused by the fault of the control valve and the quick-closing valve.)
- The water tank can be filled with water by the altitude valve.
- If it is necessary, the water can be transported out. (The pressure of the supply system is lower than the pressure of the water tank.)
- Can control the water level of the water tank by the adjustment of the ball float. Can be used for irrigation.
- When the pump is started and stopped or the power supply system has the faults, it can avoid pressure fluctuation.
- Can avoid pressure fluctuation, when the pump is started and stopped.
- Control the water flow in the industrial zone.
- The current can be distributed into two supply systems.

MAIN PARTS CONSTRUCTION

Component list: FIG.1

1. Bonnet
2. Compression spring
3. Stem
4. Diaphragm clamping plate
5. Diaphragm
6. Body
7. Gasket
8. Disc

Component list: FIG.2

1. Bonnet
2. Cylinder liner
3. Piston
4. O-ring
5. Stem
6. Disc
7. Gasket
8. Body
9. Gasket clamping plate

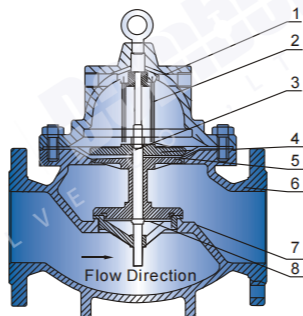

FIG.1-Diaphragm type

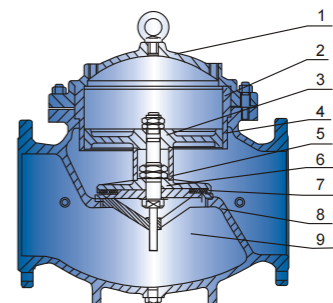

FIG.2-Piston type

DESIGN FEATURES:

The DBV hydraulic control valve has two types: diaphragm type and piston type. The operating principles of the both types are the same. It is made up of a main valve (shown as the FIG.1 and FIG.2) and needle valve, pilot valve, conduct pipe and pressure gauge etc. and move and operate together. For the difference of purpose, function and location, it evolves into remote float control valve, pre-determined float control valve, pressure reducing valve, slow control check valve, flow control valve, pressure relief or sustaining, hydraulic motor control valve, pump control valve, emergency shut off valve etc.

OPERATING PRINCIPLE:

The DBV hydraulic control valve is driven by the pressure difference ΔP , controlled by the pilot valve to make the piston operate by the difference of hydraulic pressure. The valve is automatically adjusted by the water power to make the valve disc of main valve fully open, close or be in state of adjusted.

1. Fully close: When the hydraulic pressure at the entry end of the main valve enters into the valve body and control room, and at the same time the ball valve closes, at this time the main valve is in full close state.
2. Fully open: while the ball valve out of the main valve fully opened, the water pressure in the control room is completely drove out to the atmosphere or the low pressure zone, so the main valve is in full open state.
3. Be floating: adjust the angle of opening to make the current between the needle valve and the ball valve balance. At this time, the main valve is in floating state.

Hydraulic Control Valve

REMOTE FLOAT CONTROL VALVE

- Cast or Ductile Iron Body Floating Ball
- Bolted Cover, Flanged Ends
- Spring Loaded, Pressure Difference Controlled
- DBV Updated Technology Design

Face to Face	DBV Standard
End Flange	DIN2532, ISO
Ratings	PN10/16/25

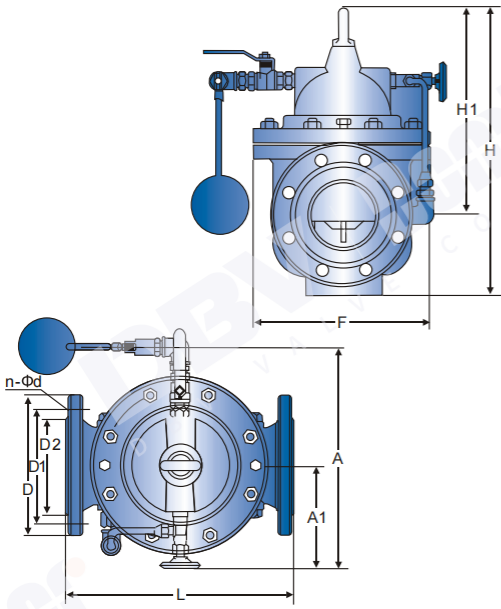

SIZE (DN)	L	A	A1	H	H1	F	D			D1			D2			n-Φd		
							PN 1.0	PN 1.6	PN 2.5	PN 1.0	PN 1.6	PN 2.5	PN 1.0	PN 1.6	PN 2.5	PN 1.0	PN 1.6	PN 2.5
20	180	262	130	212	179	116	105	105	105	75	75	75	58	58	56	4-13.5	4-13.5	4-14
25	180	262	130	212	179	116	115	115	115	85	85	85	68	68	65	4-13.5	4-13.5	4-14
32	180	262	130	212	179	116	140	140	140	100	100	100	78	78	76	4-17.5	4-17.5	4-18
40	240	280	139	265	210	170	150	150	150	110	110	110	88	88	84	4-17.5	4-17.5	4-18
50	240	280	139	265	210	170	165	165	165	125	125	125	102	102	99	4-17.5	4-17.5	4-18
65	250	284	141	310	215	180	185	185	185	145	145	145	122	122	118	4-17.5	4-17.5	8-18
80	285	292	145	350	245	210	200	200	200	160	160	160	133	133	132	8-17.5	8-17.5	8-18
100	360	330	164	460	305	275	220	220	235	180	180	190	158	158	156	8-17.5	8-17.5	8-22
125	400	340	169	520	365	310	250	250	270	210	210	220	184	184	184	8-17.5	8-17.5	8-26
150	455	350	174	570	415	355	285	285	300	240	240	250	212	212	211	8-22	8-22	8-26
200	585	392	195	695	510	460	340	340	360	295	295	310	268	268	274	8-22	12-22	12-26
250	650	442	220	780	560	500	395	405	425	350	355	370	320	320	330	12-22	12-26	12-30
300	800	472	235	905	658	580	445	460	485	400	410	430	370	370	389	12-22	12-26	16-30
350	860	532	265	1025	696	640	505	520	555	460	470	490	430	430	448	16-22	16-26	16-33
400	960	582	290	1080	735	715	565	580	620	515	525	550	482	482	503	16-26	16-30	16-36
450	1075	632	320	1030	610	780	615	640	670	565	585	600	532	532	548	20-26	20-30	20-36
500	1075	682	350	1135	665	830	670	715	730	620	650	660	585	585	609	20-26	20-33	20-36
600	1230	763	390	1270	725	920	780	840	845	725	770	770	685	685	720	20-30	20-36	20-39
700	1650	832	420	1460	865	980	895	910	960	840	840	875	800	800	820	24-30	24-36	24-42
800	1750	932	470	1640	975	1050	1015	1025	1085	950	950	990	905	905	928	24-33	24-39	24-48

PRESSURE REDUCING VALVE

- Cast or Ductile Iron Body
- Bolted Cover, Flanged Ends
- Spring Loaded, Pressure Difference Controlled
- DBV Updated Technology Design
- Sewage or Water Treatment Applications

Face to Face	DBV Standard
End Flange	DIN2532, ISO
Ratings	PN10/16/25

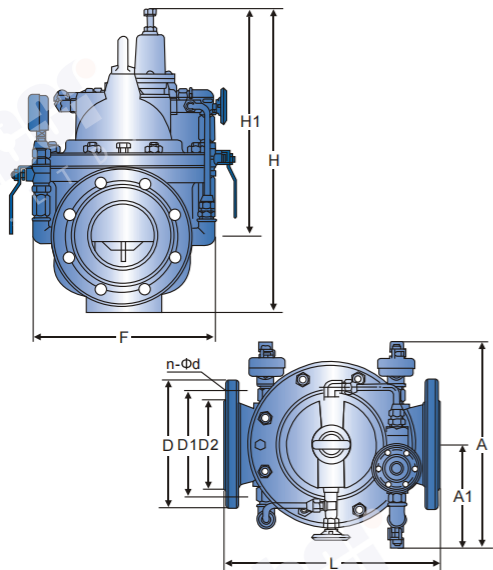

SIZE (DN)	L	A	A1	H	H1	F	D			D1			D2			n-Φd		
							PN 1.0	PN 1.6	PN 2.5	PN 1.0	PN 1.6	PN 2.5	PN 1.0	PN 1.6	PN 2.5	PN 1.0	PN 1.6	PN 2.5
20	180	292	136	342	247	116	105	105	105	75	75	75	58	58	56	4-13.5	4-13.5	4-14
25	180	292	136	342	247	116	115	115	115	85	85	85	68	68	65	4-13.5	4-13.5	4-14
32	180	292	136	342	247	116	140	140	140	100	100	100	78	78	76	4-17.5	4-17.5	4-18
40	240	330	155	395	278	170	150	150	150	110	110	110	88	88	84	4-17.5	4-17.5	4-18
50	240	330	155	395	278	170	165	165	165	125	125	125	102	102	99	4-17.5	4-17.5	4-18
65	250	350	165	405	298	180	185	185	185	145	145	145	122	122	118	4-17.5	4-17.5	8-18
80	285	365	175	430	313	210	200	200	200	160	160	160	133	133	132	8-17.5	8-17.5	8-18
100	360	410	195	510	350	275	220	220	235	180	180	190	158	158	156	8-17.5	8-17.5	8-22
125	400	455	220	560	365	310	250	250	270	210	210	220	184	184	184	8-17.5	8-17.5	8-26
150	455	478	230	585	420	355	285	285	300	240	240	250	212	212	211	8-22	8-22	8-26
200	585	530	255	675	450	460	340	340	360	295	295	310	268	268	274	8-22	12-22	12-26
250	650	523	300	730	470	500	395	405	425	350	355	370	320	320	330	12-22	12-26	12-30
300	800	700	340	760	490	580	445	460	485	400	410	430	370	370	389	12-22	12-26	16-30
350	860	840	415	840	526	640	505	520	555	460	470	490	430	430	448	16-22	16-26	16-33
400	960	880	430	910	570	715	565	580	620	515	525	550	482	482	503	16-26	16-30	16-36
450	1075	930	460	1030	610	780	615	640	670	565	585	600	532	532	548	20-26	20-30	20-36
500	1075	980	490	1135	665	830	670	715	730	620	650	660	585	585	609	20-26	20-33	20-36
600	1230	1060	530	1270	725	920	780	840	845	725	770	770	685	685	720	20-30	20-36	20-39
700	1650	1130	560	1460	865	980	895	910	960	840	840	875	800	800	820	24-30	24-36	24-42
800	1750	1230	610	1640	975	1050	1015	1025	1085	950	950	990	905	905	928	24-33	24-39	24-48

AUTOMATIC AIR RELEASE VALVE

- Iron, Steel or Bronze/Brass Body
- Floating Ball, Bolted Cover or Uni-body
- DBV Updated Technology Design
- Sewage or Water Treatment Applications

Face to Face	DBV Standard
End Flange	DIN2532, ISO
Ratings	PN10/16

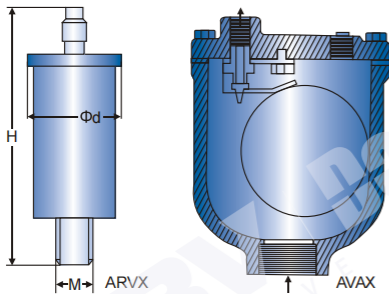

SIZE (DN)	INLET SIZE	OUTLET SIZE	ORIFICE	OVERALL DIMENSION L*W*H	Unit: mm
15	1/2	1/4	1.6	102×86×127	
20	3/4	1/4	1.6	102×86×127	
25	1	1/4	1.6	102×86×127	

SIZE (DN)	Φd	H	M in	Unit: mm
10	47	113	3/8	
15	47	113	1/2	
20	47	113	3/4	
25	47	113	1	

AUTOMATIC AIR RELEASE VALVE DOUBLE BALL & SINGLE BALL TYPE

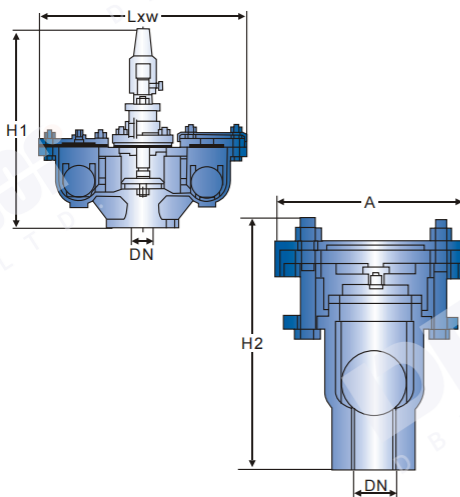

SIZE (DN)	13	25	50	80	100	150	200	Unit: mm
H1			454	454	540	710	800	
L			268	504	555	745	850	
W			184	200	536	285	340	
A	152	152	180					
H2	170	188	210					

COMBINATION AIR RELEASE VALVE

- Iron or Steel Body
- Floating Ball, Bolted Cover with Gauge
- DBV Updated Technology Design
- Sewage or Water Treatment Applications

Face to Face	DBV Standard
End Flange	DIN2532, ISO
Ratings	PN10/16

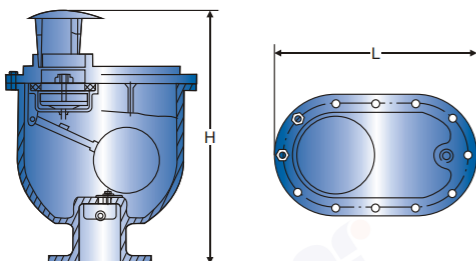

SIZE (DN)	L	H	H1	Hole No.	Hole Dia.	Unit: mm
25	280	176	330	3	17.5	
32	280	176	330	4	17.5	
50	360	208	475	4	17.5	
65	360	208	475	4	17.5	
80	400	244	552	8	17.5	
100	465	275	623	8	17.5	
150	537	332	686	8	22	
200	537	332	686	8/12	22	

Hydraulic Control Valve

FOOT VALVE

- Iron Body with S.S. Screen,
- Flanged Ends, Spring Loaded
- DBV Updated Technology Design
- Sewage or Water Treatment Applications

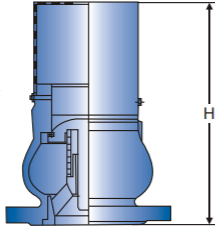

Face to Face	ISO
End Flange	ANSI B16.1, B16.5
Ratings	ANSI 125/150

MATERIAL

Body	Cast iron/Ductile iron
Disc	Cast iron/Ductile iron
Disc ring	NBR
Spring	stainless steel/steel with zinc
Screen	stainless steel/steel zinc plated

DIMENSION

SIZE (DN)	50	65	80	100	125	150	200	250	300
L	120	120	140	170	200	220	288	344	385
H	166	201	221	265	300	360	470	568	653

Unit: mm

FIRE HYDRANT

- Iron Body and Bonnet
- Flanged Ends, Bolted Cover
- DBV Updated Technology Design

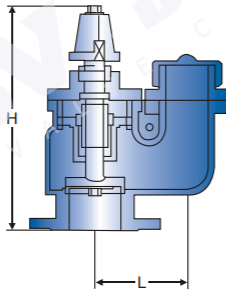

Face to Face	DBV Standard
End Flange	BS4504
Ratings	PN16

MATERIAL

1	Body	Cast iron/Ductile iron
2	Bonnet	Cast iron/Ductile iron
3	Topkey	Cast iron/Ductile iron
4	Stem	stainless steel
5	Disc	Cast iron/Ductile iron coated by NBR/EPDM
6	Bolt & Nut	stainless steel/steel with zinc plated

DIMENSION

SIZE (DN)	L	H
80	141	373

Unit: mm

DIRECT ACTION PRESSURE REDUCING VALVE

- Bronze or S.S Body
- Bolted Cover, Threaded Ends
- Spring Loaded, Over-pressure Controlled
- DBV Updated Technology Design
- Sewage or Water Treatment Applications

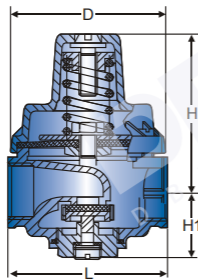

Face to Face	DBV Standard
End Flange	DIN2532, ISO
Ratings	PN10/16/25

COMPONENT LIST:

1. Bonnet	3. Control stem	5. Body	7. Plug screw
2. Spring	4. Diaphragm	6. Disc	

DIMENSION

DN	D	H	H1	L
15	59	60	31	76.5
20	73	75	31	76.5
25	81	88	36	85
32	81	93	42	98
40	85	98	45	102
50	98	130	54	117

Unit: mm

200P PRESSURE REDUCING VALVE

- Bronze or S.S Body
- Bolted Cover, Threaded Ends
- Spring Loaded, Over-pressure Controlled
- DBV Updated Technology Design
- Sewage or Water Treatment Applications

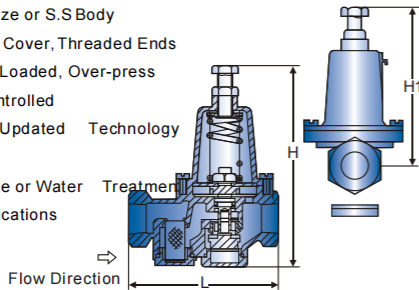

Face to Face	DBV Standard
End Flange	DIN2532, ISO
Ratings	PN10/16/25

COMPONENT LIST:

1. Adjustable bolt	3. Spring	5. Gasket
2. Nut cap	4. Diaphragm	6. Body

DIMENSION

SIZE (DN)	L	H	H1
15	112	170	130
20	112	183	130
25	135	189	143
32	165	242	195
40	192	273	222
50	231	307	252
65	235	328	

Unit: mm

HYDRAULIC COUNTERWEIGHT BUTTERFLY VALVE

DESCRIPTION:

DBV hydraulic counterweight butterfly valves are of casting design with lens disc. Double eccentric positioning of the disc permits smooth raising and resetting of the disc-seal from/on the sealing surface. With double sealing system

On the shafts and special profile of the disc seal for positive, long term tightness.

With standard seals materials this type of valves may be used in liquid and gaseous service for temperatures up to 150°C.

MAIN MATERIALS:

Parts	Material
Body	Carbon steel
Seat ring	Stainless steel
Disc	Carbon steel
Clamping ring	Carbon steel
Shaft	Stainless steel
Main sealing	Buna N (rubber)
Seals	Buna N (rubber)
Bushings	Slide bearings

Other materials are available on request

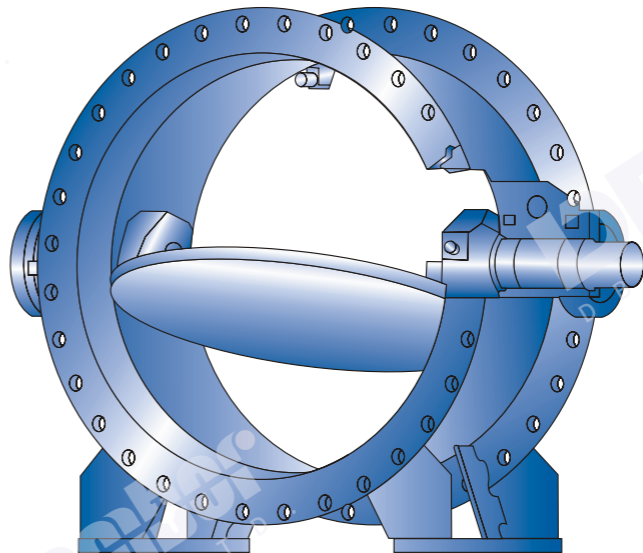

GENERAL CONSTRUCTION

1. Bare shaft

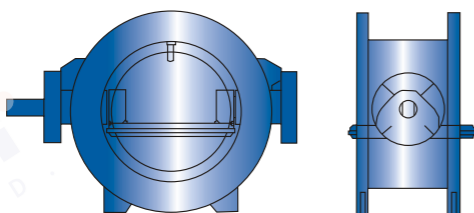

2. Counterweight and servomotor

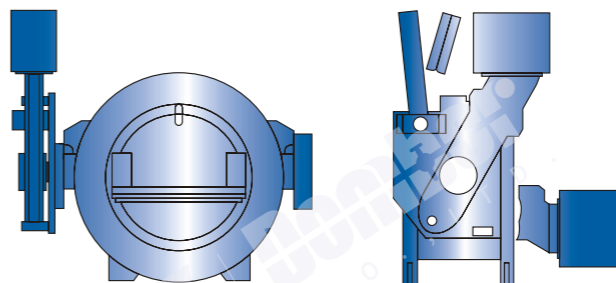

3. Worm gear unit + Electric actuator

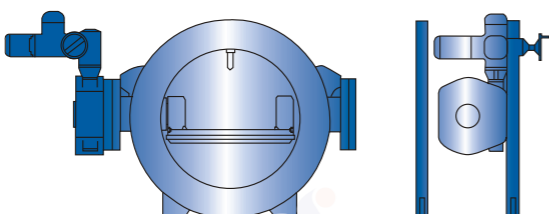

4. Worm gear unit + Handwheel

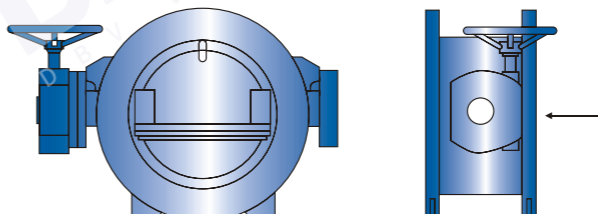

Counterweight Butterfly Valve

HYDRAULIC COUNTERWEIGHT BUTTERFLY VALVE

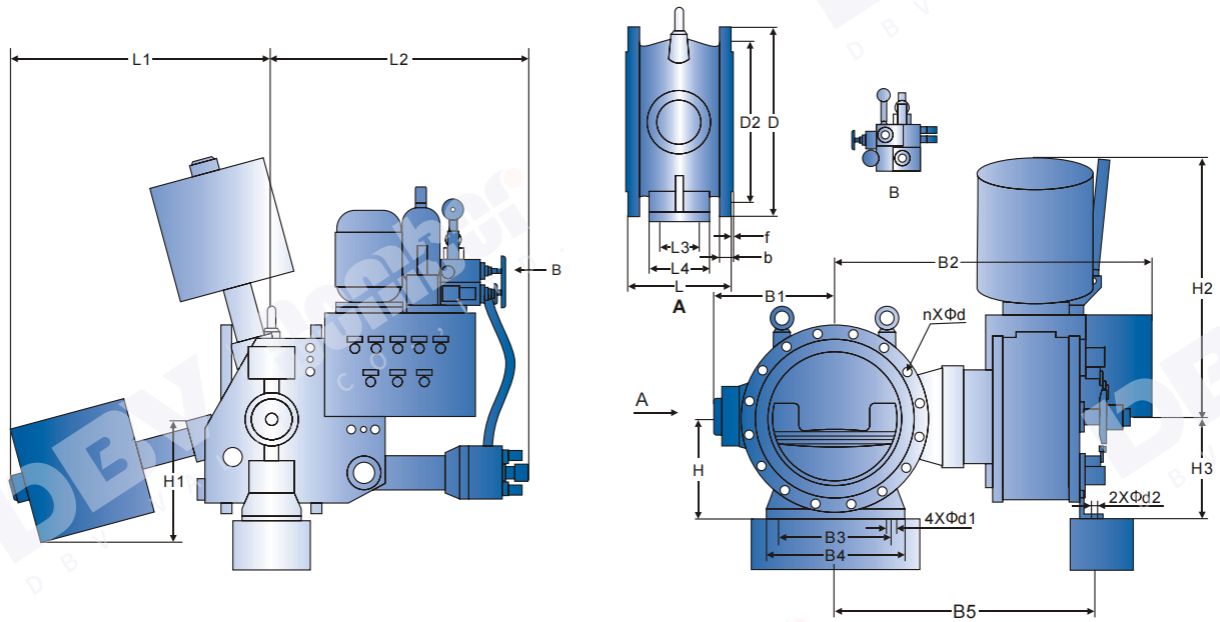

HYDRAULIC COUNTERWEIGHT BUTTERFLY VALVE (DN ≤ 500)

HYDRAULIC COUNTERWEIGHT BUTTERFLY VALVE

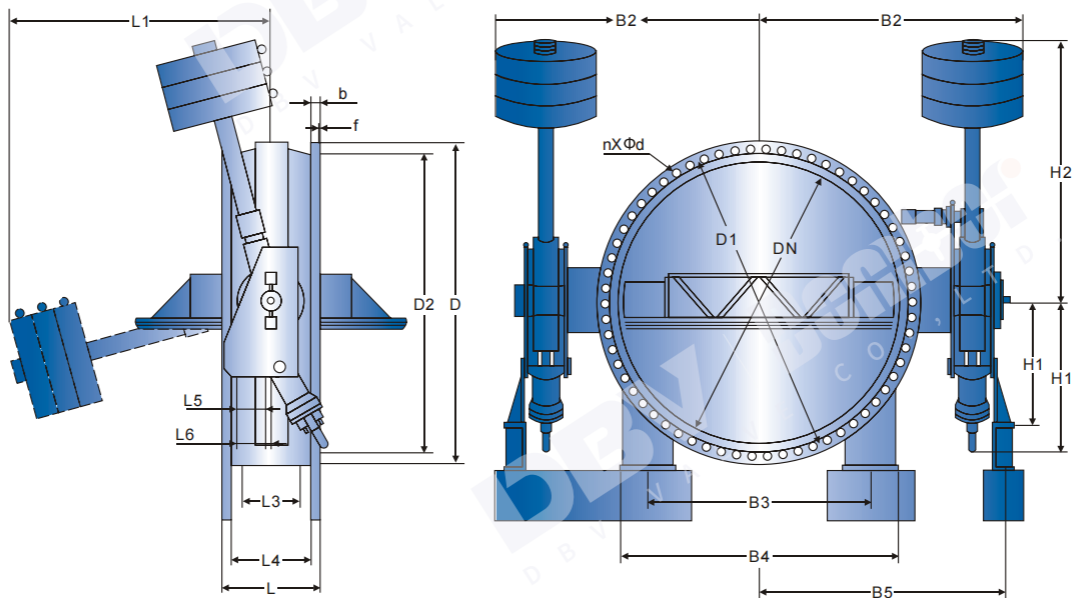

HYDRAULIC COUNTERWEIGHT BUTTERFLY VALVE (DN ≥ 600)

Counterweight Butterfly Valve

PN16 DIMENSION

SIZE (DN)	L	D	D1	D2	b	f	n	d	L1	L2	L3	L4	L5	L6	H	H1	H2	H3	B1	B2	B3	B4	B5	b1	d1	e	d2
300	270	460	410	375	26	4	12	27	1000	850	100	150	120	180	300	495	965	280	280	900	320	380	683	30	30		
350	290	520	470	429	28	4	16	27	1000	850	100	140	120	180	320	495	965	280	305	930	320	380	713	30	30		
400	310	580	525	480	32	4	16	31	1000	850	120	180	120	180	350	495	965	280	365	980	340	420	765	30	30		
500	350	715	650	609	34	4	20	34	1400	860	150	220	120	180	400	840	1380	610	440	1045	400	500	830	40	32	65	24
600	390	840	770	720	35	5	20	37	1400	860	150	250	160	220	460	840	1380	610	525	1210	450	550	965	40	32	65	24
700	430	910	840	794	35	5	24	37	1600	860	180	290	160	220	520	915	1575	685	555	1250	570	700	1005	40	32	40	24
800	470	1025	950	901	40	5	24	40	1600	860	180	310	160	220	580	915	1575	685	605	1300	650	780	1055	40	32	40	24
900	510	1125	1050	1001	40	5	28	40	1600	860	180	320	160	220	640	915	1575	685	670	1360	700	860	1110	40	35	40	24
1000	550	1255	1170	1112	42	5	28	43	1800	870	200	360	160	220	690	1030	1755	820	755	1530	740	900	1287	40	35	40	24
1100	550	1370	1280	1222	42	5	28	43	1800	870	200	360	160	220	750	1030	1755	820	805	1580	760	920	1337	40	35	40	24
1200	630	1485	1390	1328	45	5	32	49	1800	870	200	360	160	220	810	1030	1755	820	855	1630	790	950	1387	40	35	40	24
1250	530	1535	1440	1378	46	5	32	49	1800	870	200	360	160	220	810	1030	1755	820	910	1670	1140	1280	1442	40	42	40	24
1300	530	1585	1490	1425	50	5	32	49	2100	870	260	400	160	220	860	1120	2050	840	935	1695	820	960	1468	40	42	40	28
1400	530	1685	1590	1530	54	5	36	49	2100	870	260	400	160	220	940	1120	2050	840	1010	1760	840	1000	1536	40	42	40	28
1500	600	1820	1710	1640	54	5	36	49	2100	870	260	400	160	220	1000	1120	2050	840	1055	1800	900	1040	1572	40	42	40	28
1600	600	1930	1820	1750	56	5	40	56	2300	950	270	400	200	280	1080	1255	2230	925	1120	1945	1100	1300	1668	40	42	40	32
1750	670	2080	1970	1900	60	5	44	56	2300	950	270	500	200	280	1130	1255	2230	925	1175	1980	1350	1500	1752	45	42	40	32
1800	670	2130	2020	1950	60	5	44	56	2300	950	270	500	200	280	1130	1255	2230	925	1210	2010	1370	1570	1778	45	42	40	32
2000	760	2345	2230	2150	65	5	48	62	2400	910	360	560	200	280	1250	1255	2340	980	1380	2180	1370	1650	1948	45	48	40	32
2200	590	2555	2440	2360	70	5	52	62	2400	910	300	450	200	280	1320	1255	2340	980	1480	2280	1600	1880	2048	45	48	40	32
2250	590	2605	2490	2410	70	5	52	62	2400	910	300	450	200	280	1330	1255	2340	980	1510	2310	1600	1880	2078	45	48	40	32

PN25 DIMENSION

SIZE (DN)	L	D	D1	D2	b	f	n	d	L1	L2	L3	L4	L5	L6	H	H1	H2	H3	B1	B2	B3	B4	B5	b1	d1	e	d2
300	270	485	430	389	34	4	16	31	1000	850	100	150	120	180	300	495	965	280	280	838	320	380	686	30	30		24
350	290	555	490	448	38	4	16	34	1000	850	100	150	120	180	320	495	965	280	305	868	320	380	713	30	30		24
400	310	620	550	503	40	4	16	37	1400	860	120	180	160	220	350	840	1380	610	365	970	340	420	815	30	32	65	24
500	350	730	660	609	44	4	20	37	1400	860	150	220	160	220	400	840	1380	610	440	1090	400	500	880	40	32	65	24
600	390	845	770	720	46	5	20	40	1600	860	150	250	160	220	460	915	1575	685	525	1210	450	550	965	40	35	40	24
700	430	960	875	820	50	5	24	43	1600	860	180	290	160	220	520	915	1575	685	555	1300	570	700	1005	40	35	40	24
800	470	1085	990	928	54	5	24	49	1600	860	180	310	160	220	580	915	1575	685	605	1350	650	780	1055	40	35	40	24
900	510	1185	1090	1028	58	5	28	49	1800	870	180	320	160	220	640	1030	1755	820	670	1410	700	860	1160	40	42	40	24
1000	550	1320	1210	1140	62	5	28	56	2100	870	200	360	160	220	690	1120	2020	840	755	1535	740	900	1287	40	42	40	24
1100	550	1425	1315	1245	65	5	28	56	2100	870	200	360	160	220	750	1120	2050	840	805	1580	760	920	1337	40	42	40	24
1200	630	1530	1420	1350	70	5	32	56	2100	870	200	360	160	220	810	1120	2050	840	855	1630	790	950	1387	40	42	40	24
1250	530	1575	1470	1400	70	5	32	56	2100	870	200	360	160	220	810	1120	2050	840	910	1740	1140	1280	1442	40	42	40	24
1300	530	1640	1530	1450	74	5	32	62	2100	870	260	400	160	220	860	1120	2050	840	935	1765	820	960	1468	40	42	40	28
1400	530	1755	1640	1560	76	5	36	62	2300	950	260	400	200	280	940	1255	2230	925	1010	1830	840	1000	1606	40	42	40	32
1500	600	1865	1750	1670	80	5	36	62	2300	950	260	400	200	280	1000	1255	2230	925	1055	1870	900	1040	1645	40	42	40	32
1600	600	1975	1860	1780	84	5	40	62	2300	950	270	400	200	280	1080	1255	2230	925	1120	1945	1100	1300	1668	40	42	40	32
1750	670	2145	2020	1935	90	5	44	70	2400	950	270	500	200	280	1130	1255	2340	980	1175	2035	1350	1500	1832	45	48	40	32
1800	670	2195	2070	1985	90	5	44	70	2400	950	270	500	200	280	1130	1255	2340	980	1210	2065	1370	1570	1858	45	48	40	32

PN40 DIMENSION

SIZE (DN)	L	D	D1	Y	b	f2	n	d	L1	L2	L3	L4	L5	L6	H	H1	H2	H3	B1	B2	B3	B4	B5	b1	d1	e	d2
300	270	515	450	364	42	3	16	33	1000	850	100	150	120	180	300	495	965	280	280	838	320	380	683	30	30		24
350	290	580	510	422	46	4	16	36	1400	860	100	140	120	180	340	840	1380	610	305	868	320	380	713	30	32		24
400	310	660	585	474	50	4	16	39	1400	860	120	180	160	220	380	840	1380	610	365	970	340	420	815	30	32	65	24
500	350	755	670	576	55	4	20	42	1400	860	150	220	160	220	430	840	1380	610	440	1090	400	500	880	40	32	65	24
600	390	890	795	676	60	4	20	48	1600	860	150	250	160	220	500	915	1575	685	525	1210	450	550	965	40	35	40	24
700	430	995	900	778	64	4	24	48	1800	870	180	290	160	220	550	1030	1755	820	555	1300	570	700	1055	40	35	40	24
800	470	1140	1030	883	72	4	24	56	1800	870	180	310	160	220	620	1030	1755	820	605	1350	650	780	1105	40	42	40	24
900	510	1250	1140	988	76	4	28	56	2100	870	180	320	160	220	680	1120	2050	840	670	1410	700	860	1160	40	42	40	24
1000	550	1360	1250	1094	80	5	28	56	2100	870	200	360	160	220	730	1120	2050	840	755	1535	740	900	1287	40	42	40	24
1100	630	1575	1460	1294	88	5	32	62	2300	950	200	360	200	280	840	1255	2230	925	855	1705	790	950	1512	40	42	40	32
1400	530	1795	1680	1494	98	5	36	62	2400	950	260	400	200	280	950	1255	2340	980	1010	1960	840	1000	1706	40	48	40	32
1600	600	2025	1900	1694	108	5	40	70	2400	950	270	400	200	280													

Counterweight Butterfly Valve

HYDRAULIC ACCUMULATION TYPE BUTTERFLY VALVE

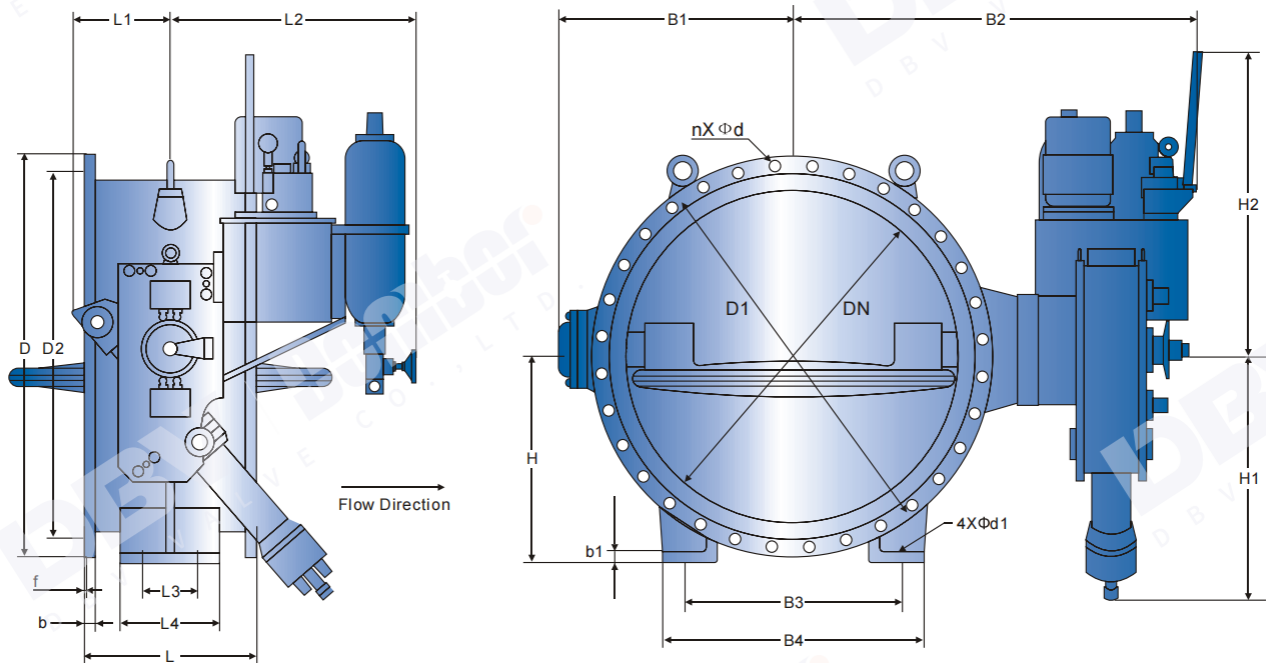

HYDRAULIC ACCUMULATION TYPE BUTTERFLY VALVE

PN2.5 DIMENSION

SIZE (DN)	L	D	D1	D2	b	f	n	d	L1	L2	L3	L4	H	H1	H2	B1	B2	B3	B4	b1	d1
300	270	435	395	366	26	4	12	23	210	705	100	150	300	650	860	280	765	320	380	30	30
350	290	490	445	413	28	4	12	23	210	705	100	140	320	650	860	305	810	320	380	30	30
400	310	540	495	463	32	4	16	23	210	705	120	180	350	650	860	365	860	340	420	30	30
500	350	645	600	568	34	4	20	23	235	740	150	220	400	730	1020	440	1016	400	500	40	32
600	390	755	705	667	35	5	20	26	235	740	150	250	460	730	1020	525	1066	450	550	40	32
700	430	860	810	772	35	5	24	26	235	740	180	290	520	730	1020	555	1080	570	700	40	32
800	470	975	920	878	40	5	24	31	235	740	180	310	580	730	1020	605	1240	650	780	40	32
900	510	1075	1020	978	40	5	24	31	380	890	180	320	640	960	1160	670	1310	700	860	40	35
1000	550	1175	1120	1078	42	5	28	31	380	890	200	360	690	960	1160	755	1360	740	900	40	35
1200	630	1375	1320	1280	45	5	32	31	380	890	200	360	810	960	1160	855	1500	790	950	40	35
1300	530	1475	1420	1380	30	5	32	31	380	890	260	400	860	960	1160	935	1565	820	960	40	42
1400	530	1575	1520	1480	30	5	36	31	460	920	260	400	940	1040	1210	1010	1630	840	1000	40	42
1500	600	1690	1630	1590	30	5	36	31	460	920	260	400	1000	1040	1210	1055	1670	900	1040	40	42
1600	600	1790	1730	1690	32	5	40	31	540	980	270	400	1080	1105	1320	1120	1830	1100	1300	40	42
1750	670	1935	1880	1840	32	5	44	31	540	980	300	500	1130	1105	1320	1175	1955	1350	1500	45	42
1800	670	1990	1930	1890	34	5	44	31	540	980	300	500	1130	1105	1320	1210	1980	1370	1570	45	42
2000	760	2190	2130	2090	34	5	48	31	680	1040	360	560	1250	1250	1380	1380	2250	1370	1650	45	42
2200	590	2405	2340	2295	36	6	52	34	680	1040	300	450	1320	1250	1380	1480	2350	1600	1880	45	42
2400	650	2605	2540	2495	38	6	56	34	850	1090	350	500	1440	1360	1540	1590	2470	1740	2020	45	42
2600	700	2805	2740	2695	40	6	60	34	850	1090	400	550	1520	1360	1540	1670	2520	1850	2200	50	42
2800	760	3030	2960	2910	42	6	64	37	850	1090	500	650	1620	1360	1540	1775	2630	2000	2400	50	48
3000	810	3230	3160	3110	42	6	68	37	920	1140	550	700	1720	1430	1620	1885	2770	2160	2560	50	48
3200	870	3430	3360	3310	44	6	72	37	920	1140	600	750	1820	1430	1620	1970	2910	2360	2760	50	48
3400	920	3630	3560	3510	46	6	76	37	920	1140	650	800	1920	1430	1620	2060	3050	2420	2920	50	48
3500	920	3730	3660	3610	48	6	78	37	920	1140	650	800	1980	1430	1620	2110	3120	2680	3180	50	48
3600	970	3840	3770	3720	48	6	80	37			650	850	2050					2750	3250	50	56
3800	1020	4045	3970	3920	48	6	80	40			750	900	2100					2880	3380	50	56
4000	1070	4245	4170	4020	50	6	84	40			800	950	2200					2980	3480	50	56

PN6 DIMENSION

SIZE (DN)	L	D	D1	D2	b	f	n	d	L1	L2	L3	L4	H	H1	H2	B1	B2	B3	B4	b1	d1
300	270	440	395	363	26	4	12	23	210	705	100	150	300	650	860	280	765	320	380	30	30
350	290	490	445	413	28	4	12	23	210	705	100	140	320	650	860	305	810	320	380	30	30
400	310	540	495	463	32	4	16	23	210	705	120	180	350	650	860	365	860	340	420	30	30
500	350	645	600	568	34	4	20	23	235	745	150	220	400	730	1020	440	1016	400	500	40	32
600	390	755	705	667	35	5	20	28	235	740	150	250	460	730	1020	525	1066	450	550	40	32
700	430	860	810	772	35	5	24	28	235	740	180	290	520	730	1020	555	1080	570	700	40	32
800	470	975	920	878	40	5	24	31	235	740	180	310	580	730	1020	605	1240	650	780	40	32
900	510	1075	1020	978	40	5	24	31	380	890	180	320	640	960	1160	670	1310	700	860	40	35
1000	550	1175	1120	1078	42	5	28	31	380	890	200	360	690	960	1160	755	1360	740	900	40	35
1200	630	1405	1340	1295	45	5	32	34	380	890	200	360	810	960	1160	855	1500	790	950	40	35
1300	530	1520	1450	1405	35	5	32	37	380	890	260	400	860	960	1160	935	1565	820	960	40	42
1400	530	1630	1560	1510	46	5	36	37	460	920	260	400	940	1040	1210	1010	1630	840	1000	40	42
1500	600	1730	1660	1610	40	5	36	37	460	920	260	400	1000	1040	1210	1055	1670	900	1040	40	42
1600	600	1830	1760	1710	50	5	40	37	540	980	270	400	1080	1105	1320	1120	1830	1100	1300	40	42
1750	670	1995	1920	1868	50	5	44	40	540	980	300	500	1130	1105	1320	1175	1955	1350	1500	45	42
1800	670	2045	1970	1918	52	5	44	40	540	980	300	500	1130	1105	1320	1210	1980	1370	1570	45	42
2000	760	2265	2180	2125	40	5	48	43	680	1040	360	560	1250	1250	1380	1380	2250	1400	1650	45	42
2200	590	2475	2390	2335	42	6	52	43	680	1040	300	450	1320	1250	1380	1480	2350	1600	1880	45	42
2400	650	2685	2600	2545	45	6	56	43	850	1090	350	500	1440	1360	1540	1590	2470	1740	2020	45	48
2600	700	2905	2810	2750	46	6	60	49	850	1090	400	550	1520	1360	1540	1670	2520	1850	2200	50	48
2800	760	3115	3020	2960	48	6	64	49	850	1090	500	650	1620	1360	1540	1775	2630	2000	2400	50	48
3000	810	3315	3220	3160	50	6	68	49	920	1140	550	700	1720	1430	1620	1885	2770	2160	2560	50	48
3200	870	3525	3430	3370	54	6	72	49	920	1140	600	750	1820	1430	1620	1970	2910	2360	2760	50	48
3400	920	3735	3640	3580	56	6	76	49	920	1140	650	800	1920	1430	1620	2060	3050	2420	2920	50	48
3500	920	3840	3745	3585	58	6	78	49	920	1140	650	800	1980	1430	1620	2110	3120	2680	3180	50	48
3600	970	3970	3860	3790	62	6	80	56			700	850	2050					2750	3250	50	56
3800	1020	4180	4065	3990	66	6	80	62			750	900	2150					2880	3380	50	56
4000	1070	4380	4265	4190	70	6	84	62			800	950	2250					2980	3480	50	56

PN10 DIMENSION

SIZE (DN)	L	D	D1	D2	b	n	f	d	L1	L2	L3	L4	H	H1	H2	B1	B2	B3	B4	b1	d1
300	270	445	400	370	26	4	12	23	210	705	100	150	300	650	860	280	765	320	380	30	30
350	290	505	460	429	28	4	16	23	210	705	100	140	320	650	860	305	810	320	380	30	30
400	310	565	515	480	32	4	16	28	210	705	120	180	350	650	860	365	860	340	420	30	30
500	350	670	620	582	34	4	20	28	235	745	150	220	400	730	1020	440	1016	400	500	40	32
600	390	780	725	682	35	5	20	31	235	740	150	250	460	730	1020	525	1066	450	550	40	32
700	430	895	840	794	35	5	24	31	235	740	180	290	520	730	1020	555	1080	570	700	40	32
800	470	1015	950	901	40	5	24	34	235	740	180	310	580	730	1020	605	1240	650	780	40	32
900	510	1115	1050	1001	40	5	28	34	380	890	180	320	640	960	1160	670	1310	700	860	40	35
1000	550	1230	1160	1112	42	5	28	37	380	890	200	360	690	960	1160	755	1360	740	900	40	35
1100	550	1340	1270	1222	42	5	28	37	380	890	200	360	750	960	1160	805	1410	760	920	40	35
1200	630	1455	1380	1328	45	5	32	40	460	920	200	360	810	1040	1210	855	1500	790	950	40	35
1250	530	1505	1430	1378	45	5	32	40	460	920	200	360	810	1040	1210	910	1525	1140	1280	40	42
1300	530	1575	1490	1425	45	5	32	43	460	920	260	400	860	1040	1210	935	1565	820	960	40	42
1400	530	1675	1590	1530	46	5	36	43	540	980	260	400	940	1105	1320	1010	1630	840	1000	40	42
1500	600	1785	1700	1640	46	5	36	49	540	980	260	400	1000	1105	1320	1055	1670	900	1040	40	42
1600	600	1915	1820	1750	50	5	40	49	540	980	270	400	1080	1105	1320	1120	1830	1100	1300	40	42
1750	670	2065	1970	1900	50	5	44	49	680	1040	300	500	1130	1250	1380	1175	1955	1350	1500	45	42
1800	670	2115	2020	1950	52	5	44	49	680	1040	300	500	1130	1250	1380	1210	1980	1370	1570	45	42
2000	760	2325	2230	2150	54	5	48	49	850	1090	360	560	1250	1360	1540	1380	2250	1370	1650	45	48
2200	590	2550	2440	2370	58	5	52	56	850	1090	300	450	1320	1360	1540	1480	2350	1600	1880	45	48
2250	590	2600	2490	2420	60	5	52	56	850	1090	300	450	1330	1360	1540	1510	2375	1600	1880	45	48
2400	650	2760	2650	2570	65	5	56	56	920	1140	350	500	1440	1430	1620	1590	2470	1740	2020	45	48

Counterweight Butterfly Valve

PN16 DIMENSION

SIZE (DN)	L	D	D1	D2	b	f	n	d	L1	L2	L3	L4	H	H1	H2	B1	B2	B3	B4	b1	d1
300	270	460	410	375	26	4	12	27	210	705	100	150	300	650	860	280	765	320	380	30	30
350	290	520	470	429	28	4	16	27	210	705	100	140	320	650	860	305	810	320	380	30	30
400	310	580	525	480	32	4	16	31	210	705	120	180	350	650	860	365	860	340	420	30	30
500	350	715	650	609	34	4	20	34	235	740	150	220	400	730	1020	440	1020	400	500	40	32
600	390	840	770	720	35	5	20	37	235	740	150	250	460	730	1020	525	1066	450	550	40	32
700	430	910	840	794	35	5	24	37	235	740	180	290	520	730	1020	555	1080	570	700	40	32
800	470	1025	950	901	40	5	24	40	380	890	180	310	580	960	1160	605	1240	650	780	40	32
900	510	1125	1050	1001	40	5	28	40	380	890	180	320	640	960	1160	670	1310	700	860	40	35
1000	550	1255	1170	1112	42	5	28	43	460	920	200	360	690	1040	1210	755	1360	740	900	40	35
1100	550	1370	1280	1222	42	5	28	43	460	920	200	360	750	1040	1210	805	1410	760	920	40	35
1200	630	1485	1390	1328	45	5	32	49	540	980	200	360	810	1105	1320	855	1500	790	950	40	35
1250	530	1535	1440	1378	46	5	32	49	540	980	200	360	810	1105	1320	910	1525	1140	1280	40	42
1300	530	1585	1490	1425	50	5	32	49	540	980	260	400	860	1105	1320	935	1565	820	960	40	42
1400	530	1685	1590	1530	54	5	36	49	540	980	260	400	940	1105	1320	1010	1630	840	1000	40	42
1500	600	1820	1710	1640	54	5	36	49	540	980	260	400	1000	1105	1320	1055	1670	900	1040	40	42
1600	600	1930	1820	1750	56	5	40	56	680	1040	270	400	1080	1250	1380	1120	1830	1100	1300	40	42
1750	670	2080	1970	1900	60	5	44	56	680	1040	300	500	1130	1250	1380	1175	1955	1350	1500	45	42
1800	670	2308	2020	1950	60	5	44	56	680	1040	300	500	1130	1250	1380	1210	1980	1370	1570	45	42
2000	760	2345	2230	2150	65	5	48	62	850	1090	360	560	1250	1360	1540	1380	2250	1370	1650	45	48
2200	590	2555	2440	2360	70	5	52	62	850	1090	300	450	1320	1360	1540	1480	2350	1600	1880	45	48
2250	590	2605	2490	2410	70	5	52	62	850	1090	350	500	1330	1360	1540	1510	2375	1600	1880	45	48

PN25 DIMENSION

SIZE (DN)	L	D	D1	D2	b	f	n	d	L1	L2	L3	L4	H	H1	H2	B1	B2	B3	B4	b1	d1
300	270	485	430	389	34	4	16	31	210	705	100	150	300	650	860	280	765	320	380	30	30
350	290	555	490	448	38	4	16	34	210	705	100	150	320	650	860	305	810	320	380	30	30
400	310	620	550	503	40	4	16	37	235	740	120	180	350	730	1020	365	860	340	420	30	32
500	350	730	660	609	44	4	20	37	235	740	150	220	400	730	1020	440	1016	400	500	40	32
600	390	845	770	720	46	5	20	40	235	740	150	250	460	730	1020	525	1066	450	550	40	35
700	430	960	875	820	50	5	24	43	380	890	180	290	520	960	1160	555	1080	570	700	40	35
800	470	1085	990	928	54	5	24	49	380	890	180	310	580	960	1160	605	1240	650	780	40	35
900	510	1185	1090	1028	58	5	28	49	380	890	180	320	640	1040	1210	670	1310	700	860	40	42
1000	550	1320	1210	1140	62	5	28	56	460	920	200	360	690	1105	1320	755	1360	740	900	40	42
1100	550	1425	1315	1245	65	5	28	56	460	920	200	360	750	1105	1320	805	1410	760	920	40	42
1200	630	1530	1420	1350	70	5	32	56	460	920	200	360	810	1105	1320	855	1500	790	950	40	42
1250	530	1575	1470	1400	70	5	32	56	460	920	200	360	810	1105	1320	910	1525	1140	1280	40	42
1300	530	1640	1530	1450	74	5	32	62	460	920	260	400	860	1105	1320	935	1565	820	960	40	42
1400	530	1755	1640	1560	76	5	36	62	540	980	260	400	940	1250	1380	1010	1630	840	1000	40	42
1500	600	1865	1750	1670	80	5	36	62	540	980	260	400	1000	1250	1380	1055	1670	900	1040	40	42
1600	600	1975	1860	1780	84	5	40	62	540	980	270	400	1080	1250	1380	1120	1830	1100	1300	40	42
1750	670	2145	2020	1935	90	5	44	70	680	1040	300	500	1130	1360	1540	1175	1955	1350	1500	45	48
1800	670	2195	2070	1985	90	5	44	70	680	1040	300	500	1130	1360	1540	1210	1980	1370	1570	45	48

PN40 DIMENSION

SIZE (DN)	L	D	D1	D2	b	n	f	d	L1	L2	L3	L4	H	H1	H2	B1	B2	B3	B4	b1	d1
300	270	515	450	364	42	3	16	33	210	705	100	150	300	650	860	280	765	320	380	30	30
350	290	580	510	422	46	4	16	36	210	705	100	170	340	650	860	305	810	320	380	30	32
400	310	660	585	474	50	4	16	39	235	740	120	180	380	730	1020	365	860	340	420	30	32
500	350	755	670	576	52	4	20	42	235	740	150	220	430	730	1020	440	1066	400	500	40	32
600	390	890	795	676	60	4	20	48	380	890	150	250	500	960	1160	525	1066	450	550	40	35
700	430	995	900	778	64	4	24	48	380	890	180	290	550	960	1160	555	1080	570	700	40	35
800	470	1140	1030	883	72	4	24	56	460	920	180	310	620	1040	1210	605	1240	650	780	40	42
900	510	1250	1140	988	76	4	28	56	540	980	180	320	680	1105	1320	670	1310	700	860	40	42
1000	550	1360	1250	1094	80	5	28	56	540	980	200	360	730	1105	1320	755	1360	740	900	40	42
1200	630	1575	1460	1294	88	5	32	62	680	1040	200	360	840	1250	1380	855	1500	790	950	40	42
1400	530	1795	1680	1494	98	5	36	62	850	1090	260	400	950	1360	1540	1010	1630	840	1000	40	48
1600	600	2025	1900	1694	108	5	40	70	850	1090	270	400	1080	1360	1540	1120	1830	1100	1300	40	48

INSTALLATION INSTRUCTION

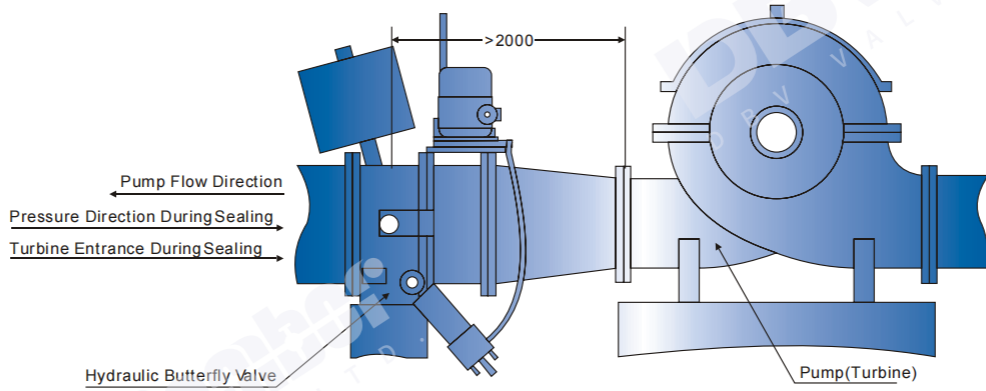

OBSERVE INSTALLATION-COUNTERWEIGHT BUTTERFLY VALVE

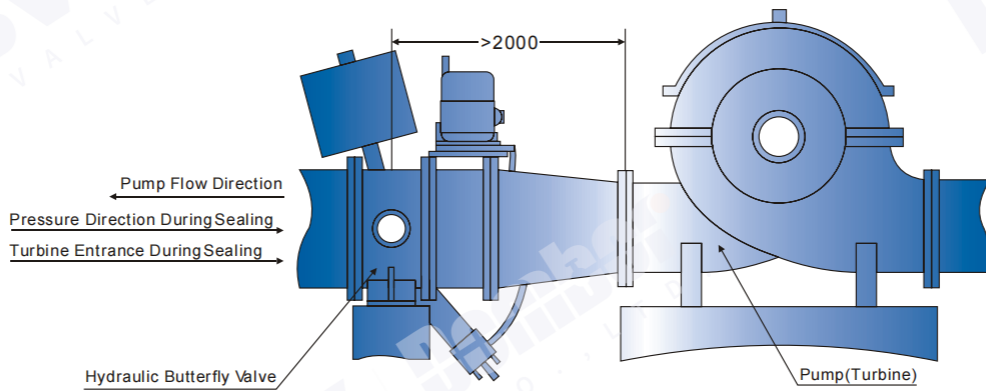

RESERVE INSTALLATION-COUNTERWEIGHT BUTTERFLY VALVE

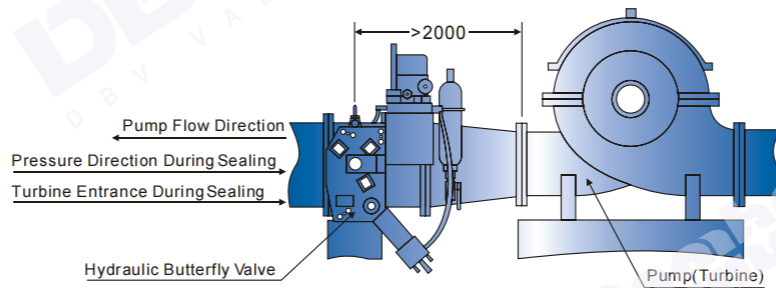

OBSERVE INSTALLATION-ACCUMULATION BUTTERFLY VALVE

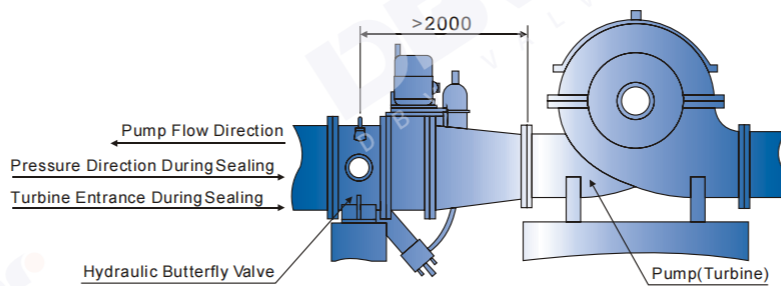

RESERVE INSTALLATION-ACCUMULATION BUTTERFLY VALVE

Spherical Valve

SPHERICAL VALVE

DESCRIPTION:

DBV spherical valves are of heavy, forged design with 3 piece short, compact body with thread holes flange connections.

Valves are equipped with movable, hydraulic operated service and maintenance seals system (metal to metal/rubber).

Maintenance works on service seal can be executed without dismantling the valve from the penstock.

These type valves have double seals (internal - external) on the shafts and special shape of the rotor seals for positive, long term tightness. With standard seals materials which may be used in liquid and gaseous service for temperatures up to 70°C.

MAIN PARTS MATERIALS:

Parts	Material type
Body	Carbon steel
Maintenance seal	Stainless steel
Seat ring	Stainless steel
Rotor	Carbon steel
shaft	Stainless steel
Main seal	Stainless steel/BUNAN /polyurethane
Clamping ring	Stainless steel
Bushings	Slide bushing
seals	Buna n (rubber)
Other materials on request	

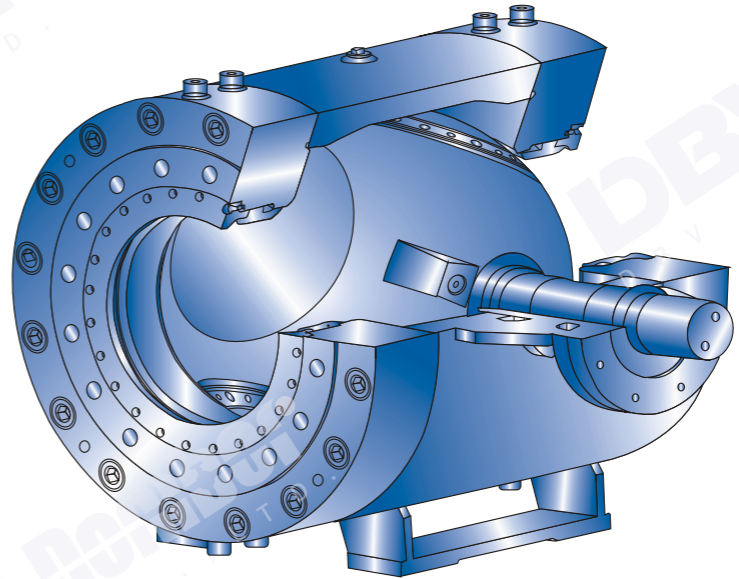

GENERAL DESIGN

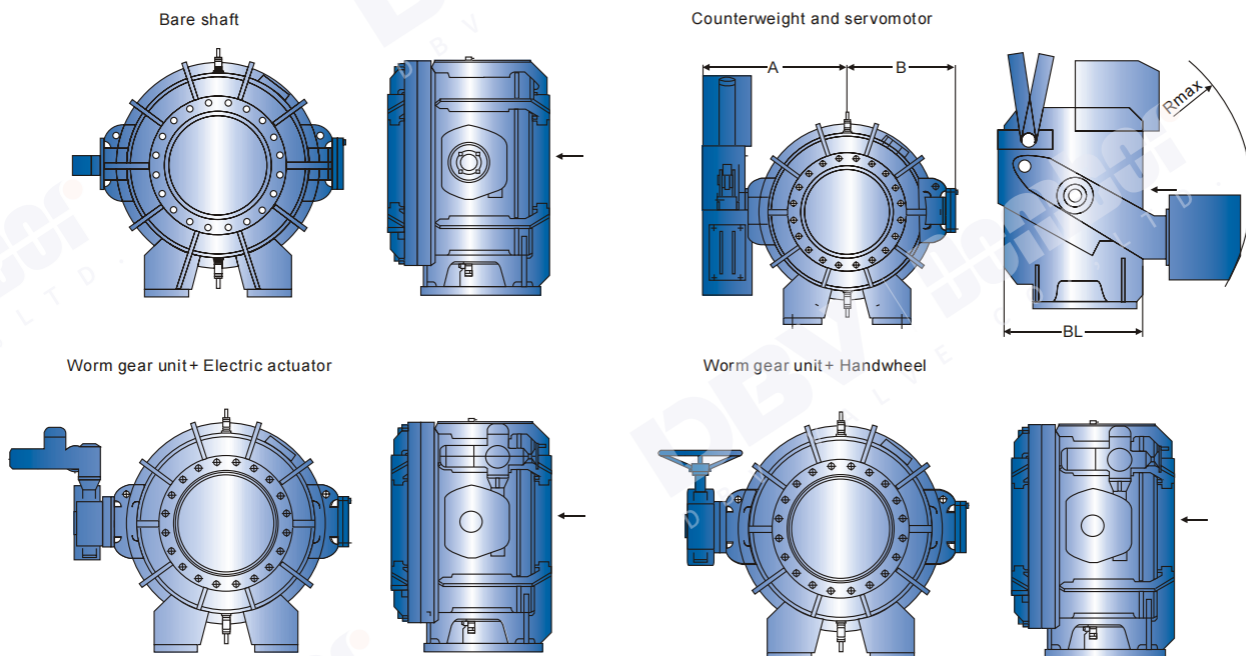

PN 25 DIMENSION

SIZE (DN)	BL	A	B	R max	W.T Counter weight (kg)	W.T Electric (kg) Unit: mm
150	420	560	360	480	640	550
200	490	620	420	580	1000	940
250	540	650	450	660	1200	1000
300	570	680	510	860	1600	1300
350	720	840	640	860	2700	2500
400	770	900	700	980	3500	3100
450	810	970	770	1200	4000	3800
500	910	1085	845	1400	5000	4500
600	1060	1140	900	1550	7200	6800
700	1210	1185	985	1550	10200	9500
800	1380	1890	1090	1650	14700	13000
900	1530	2075	1175	1650	19000	17600
1200	1700	2150	1300	1700	23000	21500
1600						

PN 40 DIMENSION

SIZE (DN)	BL	A	B	R max	W.T Counter weight (kg)	W.T Electric (kg) Unit: mm
150	420	560	360	660	700	600
200	490	620	420	860	1200	900
250	540	650	450	980	1300	1100
300	570	680	510	1200	1700	1400
350	720	840	640	1400	3100	2500
400	770	900	700	1550	3800	3100
450	810	970	770	1550	4600	3800
500	910	1085	845	1650	6300	4600
600	1060	1140	900	1650	8650	6900
700	1210	1185	985	1650	11300	9600
800	1380	1890	1090	1800	15700	13100
900	1530	2075	1175	2000	19200	17800
1200	1700	2250	1430	1720	24000	22500
1600						

PN 64 DIMENSION

SIZE (DN)	BL	A	B	R max	W.T Counter weight (kg)	W.T Electric (kg) Unit: mm
150	420	560	360	800	700	570
200	490	620	420	800	1200	950
250	540	650	450	860	1300	1100
300	570	680	510	980	1700	1400
350	720	840	640	980	3100	2600
400	770	900	700	1100	3800	3200
450	810	970	770	1200	4600	4400
500	910	1085	845	1550	6300	6000
600	1060	1140	900	1650	8600	8000
700	1210	1185	985	1800	11400	1100
800	1380	1890	1090	2000	15700	1500
900	1530	2075	1175	2200	19200	1900
1200	1700					

PN 100 DIMENSION

SIZE (DN)	BL	A	B	R max	W.T Counter weight (kg)	W.T Electric (kg) Unit: mm
150	420	560	360	980	790	465
200	490	620	420	980	1065	770
250	540	650	450	1100	1160	890
300	570	680	510	1550	1700	1055
350	720	840	640	1550	2890	2120
400	770	900	700	1650	4360	2600
450	810	970	770	1650	4900	3240
500	910	1085	845	1800	6700	3835
600	1060	1140	900	1800	9000	6300
700	1210	1185	985			
800	1380	1890	1090			
900	1530	2075	1175			
1200	1700					

Flange in accordance with ISO / DIN.

Flanges in accordance with ANSI and MSS available on request.

Dimensions and weights are preliminary only. Final dimensions and weights will be established after detail design of each valve is completed.

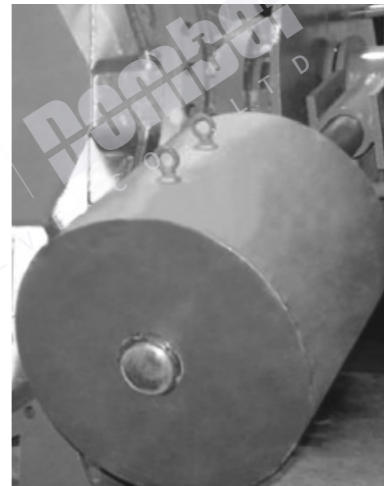
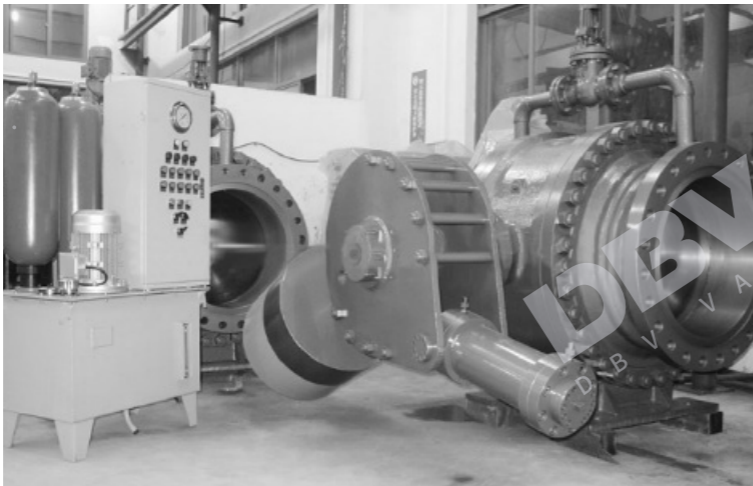

Marine Valve

MARINE BRONZE GLOBE VALVE

- Marine Bronze Globe Valve
- Outside Screw and York, Bolted Bonnet, Rising Stem
- Swivel Plug Disc
- Designed to JIS Standards

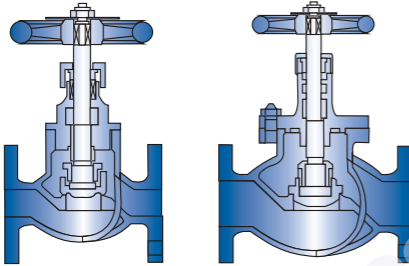

(5K-15A AND 40A)

(5K-50A AND 65A)

Face to Face	JIS F7301/F7303
End Flange	JIS
Ratings	JIS 5K/16K

F7301 JIS 5K DIMENSION

SIZE (DN)	FACE TO FACE	DIA	FLANGE PCD	BOLT HOLE	HEIGHT	H.W DIA	W.T (kg)	Unit: mm
15	100	80	60	4-12	130	80	2.02	
20	110	85	65	4-12	145	100	2.86	
25	120	95	75	1-12	160	125	3.54	
32	140	115	90	4-15	170	125	5.00	
40	160	120	95	4-15	190	140	6.48	
50	210	130	105	4-15	235	140	11.70	
65	250	155	103	4-15	260	160	17.00	

F7303 JIS 16K DIMENSION

SIZE (DN)	FACE TO FACE	DIA	FLANGE PCD	BOLT HOLE	HEIGHT	H.W DIA	W.T (kg)	Unit: mm
15	110	95	70	4-15	130	80	2.76	
20	120	100	75	4-15	140	100	3.72	
25	130	125	90	4-19	160	125	5.20	
32	160	135	100	4-19	170	125	6.91	
40	180	140	105	4-19	190	140	8.43	

MARINE BRONZE RISING STEM GATE VALVE

- Marine Bronze Gate Valve
- Outside Screw and York, Bolted Bonnet, Rising Stem
- Designed to JIS Standards

Face to Face	JIS F7367/F7368
End Flange	JIS
Ratings	JIS 5K/10K

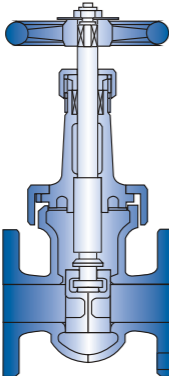

F7367 JIS 5K DIMENSION

SIZE (DN)	FACE TO FACE	DIA	FLANGE PCD	BOLT HOLE	HEIGHT	H.W DIA	W.T (kg)	Unit: mm
15	90	80	60	4-12	175	80	2.29	
20	100	85	65	4-12	200	80	2.98	
25	110	95	75	1-12	220	100	4.10	
32	130	115	90	4-15	250	100	5.79	
40	140	120	95	4-15	290	125	7.78	

F7368 JIS 16K DIMENSION

SIZE (DN)	FACE TO FACE	DIA	FLANGE PCD	BOLT HOLE	HEIGHT	H.W DIA	W.T (kg)	Unit: mm
15	100	95	70	4-15	175	80	2.96	
20	110	100	75	4-15	200	80	3.89	
25	120	125	90	4-19	220	100	5.82	
32	140	135	100	4-19	250	100	7.52	
40	150	140	105	4-19	290	125	9.71	

MARINE BRONZE ANGLE VALVE

- Marine Bronze Angle Valve
- Outside Screw and York, Bolted Bonnet, Rising Stem
- Designed to JIS Standards

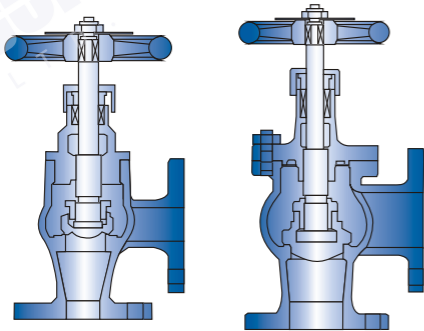

(5K-15A AND 40A)

(5K-50A AND 65A)

Face to Face	JIS F7302/F7304
End Flange	JIS
Ratings	JIS 5K/16K

F7302 JIS 5K DIMENSION

SIZE (DN)	FACE TO FACE	DIA	FLANGE PCD	BOLT HOLE	HEIGHT	H.W DIA	W.T (kg)	Unit: mm
15	50	80	60	4-12	120	80	1.98	
20	60	85	65	4-12	130	100	2.73	
25	65	95	75	1-12	145	125	3.44	
32	80	115	90	4-15	150	125	4.77	
40	85	120	95	4-15	165	140	5.99	
50	100	130	105	4-15	200	140	10.10	
65	115	155	108	4-15	220	160	15.60	

F7304 JIS 16K DIMENSION

SIZE (DN)	FACE TO FACE	DIA	FLANGE PCD	BOLT HOLE	HEIGHT	H.W DIA	W.T (kg)	Unit: mm
15	70	95	70	4-15	120	80	2.73	
20	75	100	75	4-15	130	100	3.65	
25	85	125	90	4-19	145	125	5.16	
32	95	135	100	4-19	150	125	6.72	
40	100	140	105	4-19	165	140	8.13	

MARINE BRONZE SWING CHECK VALVE

- Marine Bronze Non Return Valve
- Bolted Cover, Swing Type Disc
- Designed to JIS Standards

Face to Face	JIS F7371
End Flange	JIS
Ratings	JIS 5K

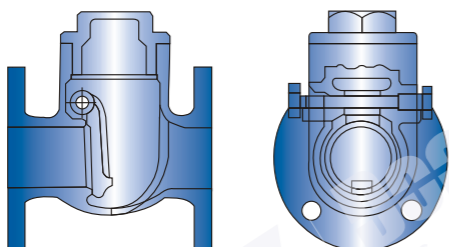

F7371 JIS 5K DIMENSION

SIZE (DN)	FACE TO FACE	DIA	FLANGE PCD	BOLT HOLE	HEIGHT	W.T (kg)	Unit: mm
25	110	95	75	4-12	69	2.24	
32	130	115	90	4-15	79	3.07	
40	140	120	95	1-15	93	4.34	

MARINE BRONZE SCREW-DOWN NON-RETURN VALVE

- Marine Bronze Screw-down NonReturn Valve
- Bolted Cover, Swing Type Disc
- Designed to JIS Standards

Face to Face	JIS F7351/F7409
End Flange	JIS
Ratings	JIS 5K/10K

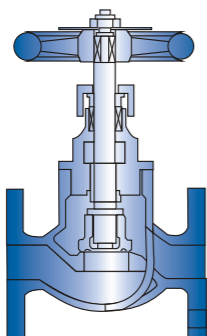

F7351 JIS 5K/F7409 JIS 10K DIMENSION

SIZE (DN)	FACE TO FACE	DIA	FLANGE PCD	BOLT HOLE	HEIGHT	W.T (kg)	Unit: mm
25	110	95	75	4-12	69	2.24	
32	130	115	90	4-15	79	3.07	
40	140	120	95	1-15	93	4.34	

MARINE BRONZE SCREW-DOWN NON-RETURN ANGLE VALVE

- Marine Bronze Screw-down NonReturn Valve
- Bolted Cover, Angle Type
- Designed to JIS Standards

Face to Face	JIS F7352/F7410
End Flange	JIS
Ratings	JIS 5K/16K

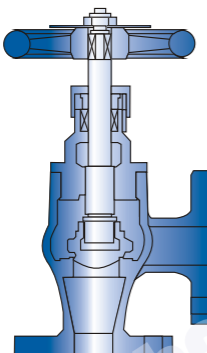

F7352 JIS 5K DIMENSION

SIZE (DN)	FACE TO FACE	DIA	FLANGE PCD	BOLT HOLE	HEIGHT	H.W DIA	W.T (kg)	Unit: mm
15	50	80	60	4-12	120	80	1.92	
20	60	85	65	4-12	130	100	2.64	
25	65	95	75	1-12	145	125	3.30	
32	80	115	90	4-15	150	125	4.63	
40	85	120	95	4-15	165	140	5.81	

F7410 JIS 16K DIMENSION

SIZE (DN)	FACE TO FACE	DIA	FLANGE PCD	BOLT HOLE	HEIGHT	H.W DIA	W.T (kg)	Unit: mm
15	70	95	70	4-15	120	80	2.67	
20	75	100	75	4-15	130	100	3.56	
25	85	125	90	4-19	145	125	5.02	
32	95	135	100	4-19	150	125	6.58	
40	100	140	105	4-19	165	140	7.95	

Marine Valve

MARINE BRONZE GATE VALVE

- Marine Bronze Gate Valve
- Outside Screw and York, Bolted Bonnet, Rising Stem
- Designed to JIS Standards

Face to Face	JIS B2026
End Flange	JIS
Ratings	JIS 10K, ANSI CL150

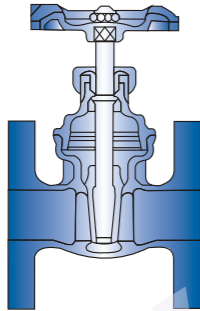

B2026 JIS 5K DIMENSION

SIZE (DN)	FACE TO FACE	DIA	FLANGE PCD	BOLT HOLE	HEIGHT
15	80	80	60	4-12	104
20	80	85	65	4-12	104
25	80	95	75	4-12	104
32	100	115	90	4-15	134
40	100	120	75	4-15	134
50	115	130	105	4-15	154
65	127	155	130	4-15	204
80	142	180	145	4-19	223
100	165	200	165	8-19	256

Unit: mm

MARINE BRONZE FLANGED COCK

- Fully in Bronze Materials
- Marine Bronze Cock
- Outside Screw and York, Bolted Cover
- Designed to JIS Standards

Face to Face	JIS F7381
End Flange	JIS
Ratings	JIS 5K

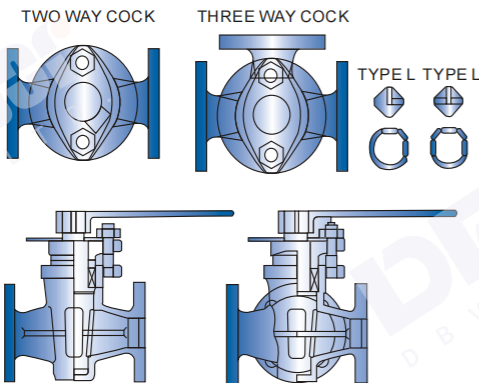

F7381 JIS 5K DIMENSION

SIZE (DN)	FACE TO FACE	DIA	FLANGE PCD	BOLT HOLE	HEIGHT	W.T (kg)	
						TWO	THREE
25	130	95	75	4-12	105	3.13	3.81
32	160	115	90	4-15	125	5.02	6.13
40	170	120	95	4-15	135	6.66	7.93
50	190	130	105	4-15	163	10.0	11.8
65	220	155	130	4-15	201	16.7	19.0

Unit: mm

MARINE FUEL OIL TANK SELF CLOSING DRAIN VALVE

- Fully in Bronze Materials
- Oil Tank Self-closing Drain Application
- Outside Screw and York, Bolted Bonnet, Rising Stem
- Designed to JIS Standards

Face to Face	JIS F7398
End Flange	JIS
Ratings	JIS 5K/10K

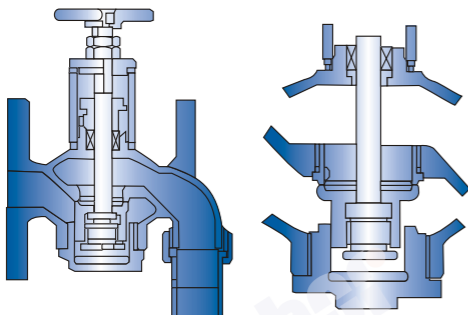

F7398 DIMENSION

SIZE (DN)	FACE TO FACE	DIA	FLANGE PCD	BOLT HOLE	HEIGHT	H.W DIA	W.T(kg)	
							TYPE U	TYPE F
25	130	125	90	4-19	130	70	3.87	4.70
40	180	140	105	4-19	165	80	7.43	8.10
50	220	155	120	4-19	195	80	12.2	12.4

Unit: mm

MARINE BRONZE FUEL OIL TANK EMERGENCY SHUT OFF VALVE

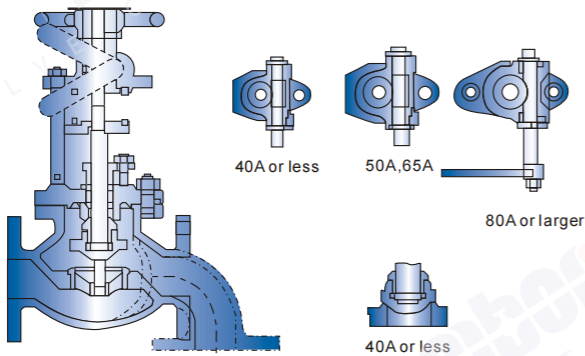

F7399 JIS 5K DIMENSION

SIZE (DN)	FACE TO FACE DIA	FLANGE PCD	BOLT HOLE	HEIGHT	H.W DIA	W.T(kg)	
						TYPE U	TYPE F
25	130	125	90	4-19	265	125	8.8
40	170	140	105	4-19	310	140	13.0
50	220	155	120	4-19	335	160	20.9
65	270	175	140	4-19	395	180	30.5
80	300	185	150	8-19	420	180	35.4
100	350	210	175	8-19	510	224	59.2

Unit: mm

MARINE BRONZE FIRE FIGHTING VALVE

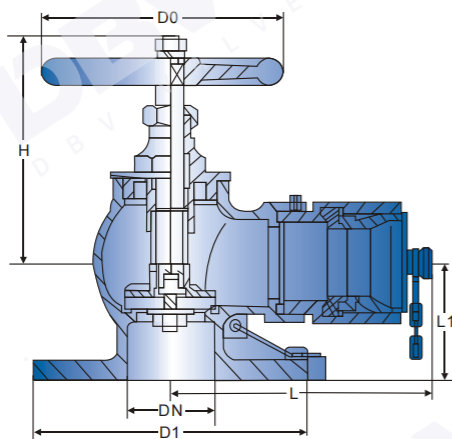

JIS 5K DIMENSION

SIZE (in.)	DN	D1	L	L1	H	Do	W.T(kg)
1-1/4"	45	155	124	68	155	100	10
2"	54	164	157	68	164	140	11.5

Unit: mm

MARINE BRONZE HOSE VALVES

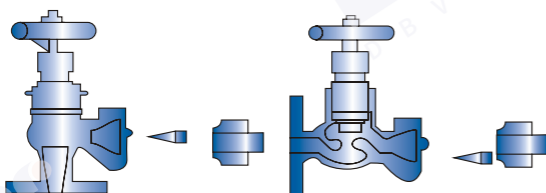

F7334 JIS 5K DIMENSION

SIZE (DN)	FACE TO FACE	DIA	FLANGE PCD	BOLT HOLE	HEIGHT	H.W DIA	W.T (kg)
15	M42X2	80	60	4-12	120	80	2.41
25	M42X2	95	75	1-12	145	125	3.44

Unit: mm

F7334 JIS 10K DIMENSION

SIZE (DN)	FACE TO FACE	DIA	FLANGE PCD	BOLT HOLE	HEIGHT	H.W DIA	W.T (kg)
15	M42X2	95	70	4-15	120	80	2.72
25	M42X2	125	90	4-19	145	125	4.04

Unit: mm

HOOK VALVE

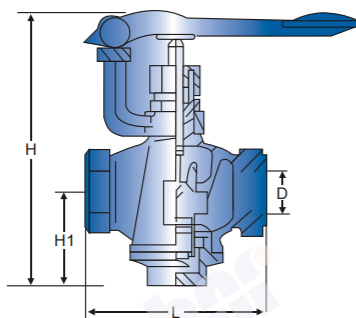

DIMENSION

SIZE (in.)	D	H	H1	L
3/4"	Z 3/4"-14NPT	130	44	84
1"	Z 1-11"-1/2NPT	152	51	84

Unit: mm



E-mail: info@dbv-armaturen.com

www.dbvvalve.com

www.dombor.com

Tel: +86-577-67387723

Fax: +86-577-67383000

Add: No.96 Fanhua East Road, OuBei, WenZhou, Zhejiang, China



DBV Web



Dombor Web



linkedin



instagram



youtube



facebook

This manual is printed on eco-paper!

Due to the continuous innovation of technology and process of "DBV" products, this information is for reference only. Our company reserves the right of final interpretation.

"DBV" and "dombor" are registered trademarks of "DBV Valve Co.,Ltd" All rights reserved. Copies must be investigated!