

Three-Way, Four-Way Ball Valve

Product Brochure



Company Profile

Company Profile

DBV Valve Co., Ltd. was established in 2001 and is headquartered in Oubei, Yongjia, Zhejiang, the hometown of pumps and valves in China. It is a modern enterprise integrating the manufacture, sales and service of various intelligent control valves (pneumatic, electric and hydraulic control). We have a factory building area of more than 20,000 square meters, more than 200 sets of machine equipment and more than 300 employees.

The company has been awarded the titles of National High-Tech Enterprise, A-class Tax Credit Enterprise of Zhejiang Province, and Star Enterprise of Yongjia County, etc. It has also been certified by American Petroleum Institute (API), Customs Union TR Declaration (EAC), German Technical Supervision Association (TUV) and Det Norske Veritas (DNV).

The company mainly produces high pressure severe service products and metal to metal seat butterfly valves, metal to metal seat ball valves, low temperature valves, etc., which are manufactured strictly according to ISO, ANSI, API, GB, HG and other standards. We have advanced physical and chemical testing centre, professional CNC machining and test pressure automatic production equipment and experienced technical production team. Product pressure from 150LB-2500LB, 0.6 MPA-42.0MPA, temperature resistance -196°C - 800°C.



Valve Production Workshop



Company Headquarters (Under Construction)



Frontline Staff

2001

Open

Year of Establishment

2016

International

International Trade Business

2018

New

Pump and Valve Base

2021

Certified

National Certification

2023

Now

Choose Us For Quality

Relying on our strict quality management system, our products are widely used in petroleum, petrochemical, natural gas, coal chemical, metallurgy, electric power and other industries, and exported to Europe, America, Asia Pacific, the Middle East and other countries and regions, the company has been approved by Oman National Oil Company, Iran South Oil Company, Thailand National Power Plant, Russia National Oil Service and other large international terminal customers.

In terms of research and manufacturing, the company has a number of senior R & D teams, advanced manufacturing equipment, perfect physical and chemical testing and inspection methods (spectrometer, helium mass spectrometer, high and low temperature comprehensive performance test equipment, etc.), scientific information management system (integrated PDM, ERP, CAD, CAPP), comprehensive resources to provide customers with sustainable product solutions and collaborative service support.

As a fluid control solutions provider, the company is committed to innovation and service enhancement and is constantly striving to become one of the world's most professional, comprehensive and reliable valve manufacturers.

Equipment & Professional Team

Equipment & Professional Team

20⁺

Years

Manufacturing Experience

200⁺

Units

Manufacturing Facilities

300⁺

People

Practitioners

3

Teams

R&d Team

20000⁺

Square Metres

Intelligent Factory Floor Space

More Than 20 Years Of Experience In R&d And Production Exported To More Than 30 Countries And Regions Worldwide.

200 + Sets Of Intelligent Manufacturing Equipment	20 + Years Of Experience In R&d And Production	Exported To 30 + Countries Worldwide
4000 + Square Metres Of Finished Goods Warehouse	Over 300 Valve Practitioners	3 Valve Production Bases
Annual Production Of Over 8000 Tons Of Valves	3 Senior Valve R&d Teams	Intelligent And Scientific Production
20,000 + Square Metres Of Factory Floor Space	Professional Multilingual Sales Staff

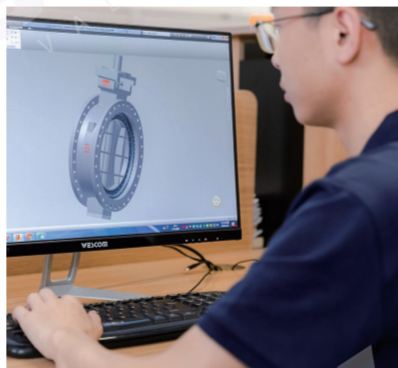

Customers & Partners

Customers & Partners



DBV Valve Co., Ltd. is a fluid control solution provider that has been developing and producing ball valves and butterfly valves in China for more than 20 years. Our sales and service network extends to dozens of overseas countries and regions, and our end products are used by companies such as Petronas, Anadarko, Petrobras, Lukoil.

The company has been approved as a qualified supplier by large international terminal customers such as Oman National Oil Company, Iran National South Oil Company, Thailand National Power Plant and Russia National Oil Company.



Honors & Qualifications

Honors And Qualifications

Qualification is the guarantee of an enterprise's products, and honour is the silent motivation of an enterprise.

In terms of product standards and quality, the company has obtained the "API6D, API609 Valve Production Design Standard Certification" issued by the American Petroleum Institute API, the "API6FA, API607 Valve Fire Test Certificate", the "SIL-3 Safety Equipment Integrity Level Certificate" issued by the German Technical Supervision Association TUV, the CE Certificate, the "ATEX Explosion Test Certificate" issued by the Norwegian Classification Society DNV and many other international certifications.

The company was awarded the title of national high-tech enterprise, the title of science and technology-based small and medium-sized enterprise in Zhejiang Province, the title of star enterprise in Yongjia County for three consecutive years, the excellent supplier of government procurement and many other honorary titles.

DBV valves are manufactured in accordance with the ISO 9001 quality management system and are subject to 48 production processes, comprehensive testing and inspection in accordance with international standards, thus guaranteeing the high quality of DBV valves.



DBV Certificates

API 6D	API 609	CE
ISO 9001	ISO 45001	ISO 14001
API 6FA/607	ISO 15848-1/API624	BS 6364
SIL-3 Ball Valve	SIL-3 Butterfly Valve	SIL-3 Control Valve
TR CU 032	TR CU 012	TR CU 010
MSK-64 Ball Valve	MSK-64 Butterfly Valve	ATEX

Multi-Field Application Solutions

Multi-Field Application Solutions

Since its inception, DBV Valve has always been deeply involved in the valve field, with scientific and cutting-edge R&D and production processes, providing reliable, safe and economical fluid control solutions to customers worldwide in a variety of industries. With years of customization of fluid control solutions, DBV Valve has developed and produced a series of valves for various industries worldwide, including but not limited to: fine chemical industry, coal chemical industry, marine industry, new energy field, oil refining and petrochemical industry, metallurgical and mining industry, pharmaceutical and pesticide industry, nuclear power industry

Industry-wide, Multi-type Fluid Control Solutions

Fine chemical industry	New Energy Sector	Pharmaceutical And Pesticide Industry
Coal chemical industry	Oil Refining And Petrochemical Industry	Nuclear Power Industry
Marine Marine Industry	Metallurgical And Mineral Industries	Technology And Environmental Industry



Three Way Flange Ball Valve

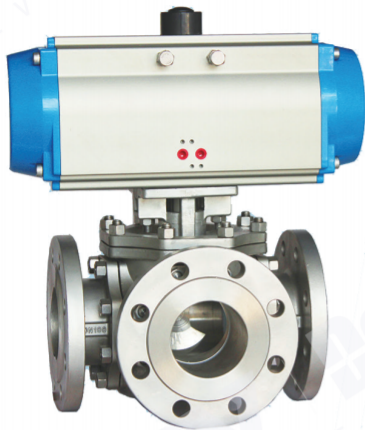

气动三通法兰球阀

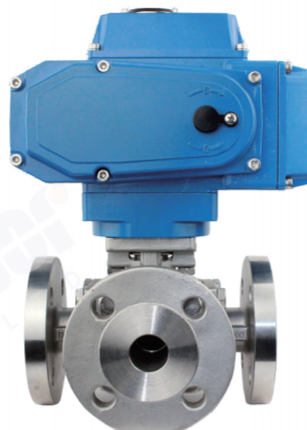

电动三通法兰球阀

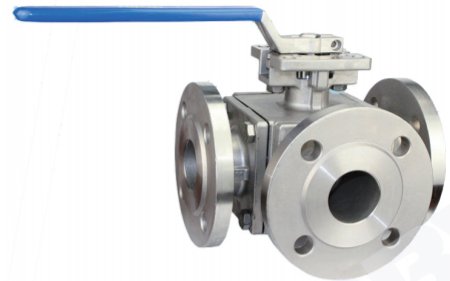

手动三通法兰球阀

三通球阀 THREE WAY BALL VALVE

产品概述

该系列 O 型三通球阀具有流通能力大、结构紧凑、密封性能好、寿命长等特点，经济实用、易于维护。广泛应用于石油、化工、天然气、电力、冶金、食品、制药等要求严密切断的场合，也可适用于水、蒸汽、油品、液化气、天然气、煤气等介质。另外可根据客户的需求选择特殊硬化处理，适用于 $-196\sim 400^{\circ}\text{C}$ ，提供更安全、更广泛的应用。

Product description

The series O-type Three-way ball valve have characteristics of large circulation capacity, compact structure, good sealing performance, long life, etc.,

economical and practical, easy to maintain. It is widely used in petroleum, chemical, natural gas, electric power, metallurgy, food, pharmaceutical and other occasions with strict requirements. It can also be applied to water, steam, oil, liquefied gas, natural gas, coal gas and other media. In addition, special hardening treatment can be selected according to customer needs, suitable for $-196\sim 400^{\circ}\text{C}$, providing safer and more extensive applications.

产品特点

1. 阀体采用精密铸造或锻造，结构紧凑、外观美观。O 型三通球阀阀芯、阀杆做旋转运动，转动阀芯时阀芯阀座始终紧密接触，具有极强的剪切能力；
2. 可设计阀座由圆柱弹簧或蝶簧预载，具有自动补偿、

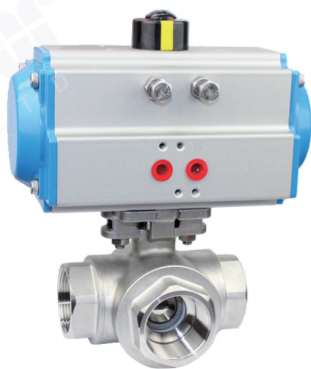

气动三通螺纹球阀



电动三通螺纹球阀



手动三通螺纹球阀

自密封和阀门中空自动泄压功能，适用于高温、高压场合；

3. 球阀旋转设计能够保证球阀运行平稳，减少操作扭矩；

4. 密封有软硬密封可选择，密封表面可硬化处理，适用于多种工况；

5. 阀门中空自动泄压设计，阀门体腔停留介质温度升高而引起异常升压时，不需通过安全阀，而仅靠阀座功能就可自动泄压，提高阀门在输送液体介质时安全性；

6. 紧急注脂救护，在有些特殊场合，由于介质中的异物或火灾造成阀座密封意外失效，注脂阀提供了与注脂枪快速连接，方便快捷地将密封脂注入到阀座密封部位，缓解泄漏；

7. 球阀有防静电结构、防阀杆吹出结构设计；

8. 加长型阀杆设计，可适用于低温场合；

9. 三通球阀任一通口均可用作入口而无泄漏，并可根据工况需要制成 L 型或 T 型通道，使安装更加方便；

10. 在系统卸压后无需拆下整个阀体就能进行检查和维修；

11. 三通球阀分为 L 型和 T 型，L 型适用于介质的流向切换，能使相互垂直的两个通道连通，T 型适用于介质的分流，合流或流向切换；

12. 两阀座密封三通球阀结构紧凑、外形美观、密封性能好，它能实现对管道介质流向的切换、也能使相互垂直的两个通道连通或关闭；

13. 四阀座密封三通球阀造型美观、结构合理、不仅可实现介质流向的切换，也可使三个通道相互连通，灵活控制管路中介质的合流或分流。

14. 四通球阀任一通口均可用作入口而无泄漏，并可根据工况需要制成各种型通道，使安装更加方便；

15. 四阀座密封四通球阀造型美观、结构合理、不仅可实现介质流向的切换，也可使四个通道相互连通，灵活控制管路中介质的合流或分流。

Features

1. The valve body adopts precision casting or forging, with compact structure and beautiful appearance. The spool and stem of the O-type three-way ball valve make a rotating movement. When the spool is turned, the spool and valve seat are always in close contact with each other, which has a strong shearing ability;

2. The valve seat can be designed to be Preload by cylindrical spring or butterfly spring, with automatic compensation, self-sealing and automatic pressure relief in the valve cavity, suitable for high temperature and high pressure occasions;

3. The rotating design of the valve ball can ensure the smooth operation of the valve ball and reduce the operating torque;

4. There are optional soft and hard seals, and the sealing surface can be hardened, suitable for a variety of working conditions;

5. The automatic pressure relief design of the valve middle cavity. When the medium temperature of the valve body cavity rises and causes abnormal pressure increase, it does not need to pass the safety valve, but can automatically relieve pressure only by the function of the valve seat, which improves the safety of the valve when conveying liquid medium. Sex

6. Emergency fat injection rescue, in some special occasions, due to foreign objects in the medium or fire caused by the accidental failure of the valve seat seal, the grease injection valve provides a quick connection with the grease injection gun, which is convenient and quick to inject the sealing grease into the valve seat sealing part To mitigate the leak;

7. Ball valve Antistatic design、Anti-flying design of valve stem;

8. The elongated stem design is suitable for low temperature applications;

9. Three-way ball valve Any port can be used as an inlet without leakage It can be made into L-shaped or T-shaped channels according to the working conditions, which makes installation more convenient;

10. Inspection and maintenance can be performed without removing the entire valve body after the system is relieved of pressure;

11. Three-way ball valves are divided into L-type and T-type. L-type is suitable for medium flow switching, which can connect two channels perpendicular to each other. T-type is suitable for medium splitting, confluence or flow direction switching;

12. The two-seat sealed three-way ball valve has a compact structure, beautiful appearance, and good sealing performance. It can switch the flow direction of the pipeline medium, and can also connect or close the two perpendicular channels;

13. The four-seat sealed three-way ball valve has a beautiful shape and reasonable structure, which can not only realize the switching of the medium flow direction, but also make the three channels communicate with each other, and flexibly control the merge or split flow of the medium in the pipeline;

14. Any port of the four-way ball valve can be used as an inlet without leakage, and can be made into various types of channels according to the working conditions, making the installation more convenient;

15. The four-seater sealed four-way ball valve has a beautiful shape and reasonable structure, which can not only realize the switching of the medium flow direction, but also make the four channels communicate with each other, and flexibly control the merge or split flow of the medium in the pipeline.

Three Way Flange Ball Valve

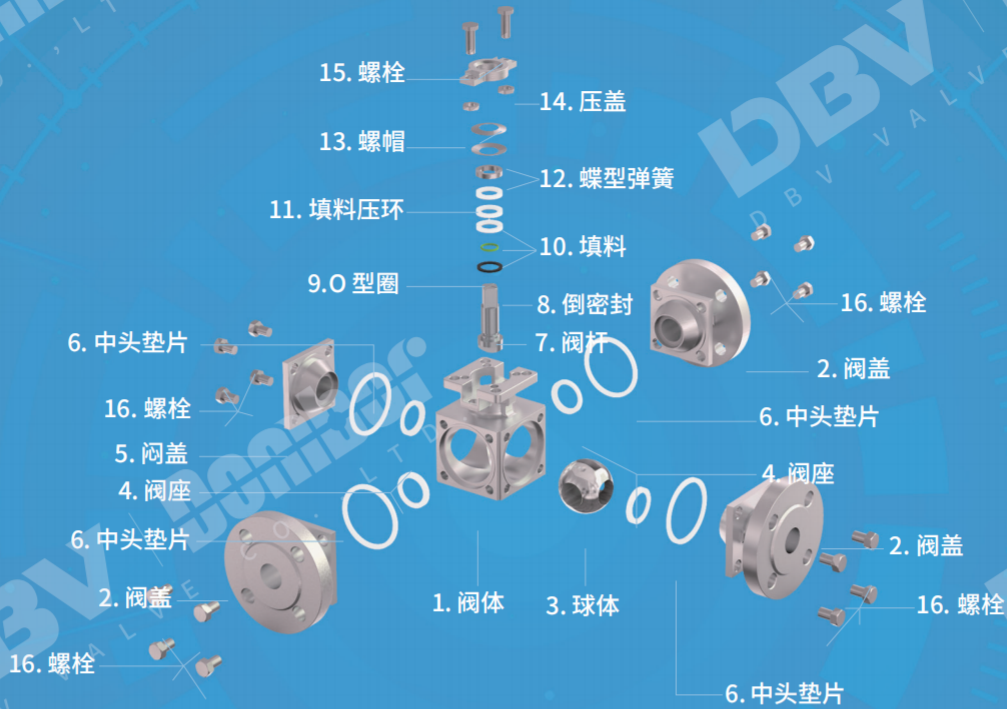

主要零件材料 Main parts materials

NO.	零件名称 PART NAME	材料 MATERIAL
1	阀体 Body	WCB、CF8、CF8M、CF3M 等
2	阀盖 Bonnet	WCB、CF8、CF8M、CF3M 等
3	球体 Ball body	SS304、SS316、SS316L、SS316L + STL 等
4	阀座 Seat	PTFE、PPL、金属密封等 (Metal seal, etc.)
5	闷盖 Cover board	WCB、CF8、CF8M、CF3M
6	中头垫片 Middle head gasket	PTFE、PPL、金属垫片 (Metal gasket)
7	阀杆 Stem	304、SS316、316L、17-4PH、S20910
8	倒密封 Inverted seal	PTFE、PPL、不锈钢缠绕石墨 (Stainless steel wound graphite)
9	O型圈 O-ring	氟橡胶 (VITON)
10	填料 Filler	PTFE、PPL、柔性石墨 (Flexible graphite)
11	填料压环 Filling clamping ring	SS304
12	蝶形弹簧 Butterfly spring	SS304
13	螺帽 NUT	2H、SS304
14	压盖 Gland of valve	CF8
15	螺栓 Screw	B7、SS304
16	螺栓 Screw	B7、SS304

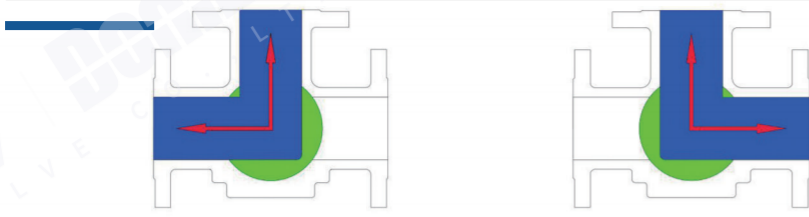

L 型三通球阀



T 型三通球阀 NO.1

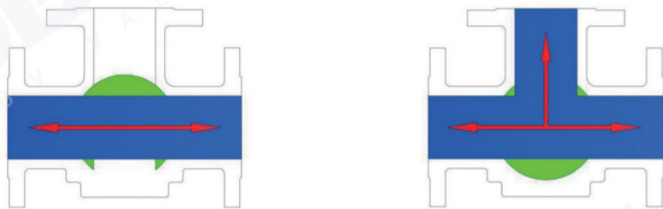

T 型三通球阀 NO.2



T 型三通球阀 NO.3

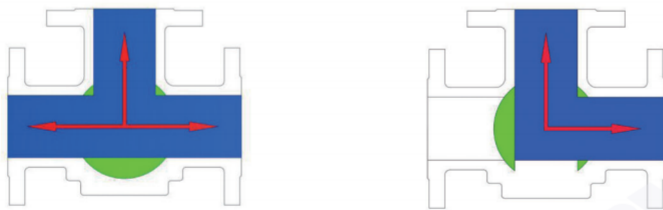

T 型三通球阀 NO.4

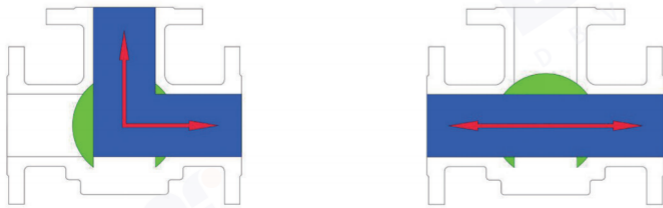

T 型三通球阀 NO.5

三通流向示意图

Schematic diagram of three-way flow

Three Way Flange Ball Valve

产品技术参数 Product Specifications

公称压力 Nominal pressure	PN1.6~42MPa、ANSI150LB~2500LB
公称通径 Nominal diameter (mm)	DN15~DN400
连接形式 Connection Type	法兰 Flange、螺纹 Thread、对焊 Butt welding、承插焊 Socket welding
阀体材料 Body material	LCB、WCB、CF8、CF8M、CF3、CF3M 等
阀座形式 Valve seat form	软阀座、金属阀座（密封面硬化处理） Soft seat、metal seat (hardened sealing surface)
适用温度 proper temperature	软阀座：-20~ + 200C° 金属阀座：-196~ + 400C° Soft seat: -20~ + 200C° Metal seat: -196~ + 400C°
泄漏等级 Leakage level	ANSI VI
设计标准 design standards	GB/T12237、ASME B16.34
结构长度 Structure length	GB/T12221、ASME B16.10
检测标准 Testing standards	GB/T13927、API598
操作方式 Operation method	手动、气动、电动等 Manual、pneumatic、electric, etc.
可选项 Optional	防静电设计、防火设计、禁油处理、禁铜处理、球面特殊处理、按客户要求涂漆 Anti-static design、fire protection design、oil-free treatment、Copper Prohibition、Spherical special treatment、Customers request painting

产品结构设计特点

Product structure design features

阀杆防吹出结构设计（见图 1）

阀杆防吹出结构设计，下端大上端小的阀杆在上端盖和螺丝的定位下，即使在阀腔异常的情况下，也能保证阀杆不会被介质吹出。

Valve stem anti-blowing structure design (see picture 1)

Valve stem anti-blowing structure design, the lower end is larger and the upper end is smaller Under the positioning of the upper end cover and screws, even in the valve cavity is abnormal In the case of, it can also ensure that the valve stem will not be blown out by the medium.

防静电设计（见图 2）

固定球阀通过防静电设计使球体、阀杆、阀体形成静电通道。从而将球体与阀座开关过程中由于摩擦产生的静电通过阀体引到大地，防止静电火花可能引起的火灾或爆炸危险。

Anti-static design (See picture 2)

The fixed ball valve adopts anti-static design to make the ball, stem and valve The body forms an electrostatic channel. So that the ball and the seat are switched During the process, static electricity generated by friction is led to the ground through the valve body, Prevent the risk of fire or explosion caused by static sparks.



图 1 (picture 1)



图 2 (picture 2)

Three Way Flange Ball Valve

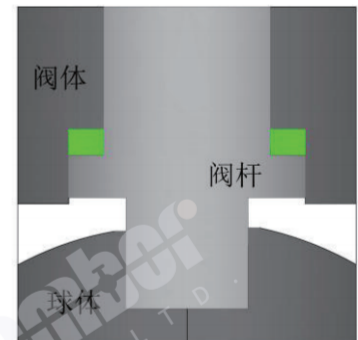
KV 值 rated

SIZE	DN15	DN20	DN25	DN32	DN40	DN50	DN65	DN80	DN100	DN125	DN150	DN200	DN250	DN300	DN350	DN400
Kv	21	38	72	112	170	275	380	512	941	1451	2220	3590	5130	7360	8750	11800

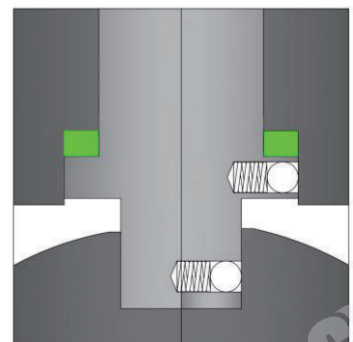
软密封力矩表 Soft seal torque table

N.m

SIZE	DN15	DN20	DN25	DN32	DN40	DN50	DN65	DN80	DN100	DN125	DN150	DN200	DN250	DN300	DN350	DN400
PN16	6	10	20	26	32	50	100	130	250	500	680	970	1620	2620	3820	5720
PN25	10	14	22	30	36	60	120	160	280	600	800	1360	2280	3740	5480	8300
PN40	14	20	48	60	70	100	200	300	500	900	1170	1992	3380	5600	8220	12600
PN63	30	60	100	130	160	200	400	600	800	1200	1780	3000	5120	8580	12640	19500
PN100	38	70	136	200	260	380	760	920	1540	1310	3780	6560	10500	14400	19720	29000
PN160	48	88	170	250	306	476	900	1150	1926	2096	4639	8232	11820	20274	28282	37732
CL150	10	14	26	36	44	60	120	160	270	600	940	1560	2210	3310	5390	6328
CL300	19	28	60	90	110	140	280	440	620	1050	1460	2400	3472	4776	6448	10278
CL600	38	70	136	200	260	380	720	920	1540	1310	3780	6560	10500	14400	19720	29000
CL900	48	88	170	250	306	476	900	1150	1926	2096	4639	8232	11820	20274	28282	37732
CL1500	64	110	230	285	342	592	1126	1436	2408	3810	7630	14430	21980	32206	49036	59260
CL2500	98	165	345	430	520	1178	1472	3154	3930	4912	11002	23572	26444	40150	63747	79800

注：黑色部分为浮动式三通四通球阀力矩表，红色部分为固定式三通四通球阀力矩表。

Note: The black part is the torque table of the floating three-way four-way ball valve, and the red part is the torque table of the fixed three-way four-way ball valve.

硬密封力矩表 Hard seal torque table

N.m

SIZE	DN15	DN20	DN25	DN32	DN40	DN50	DN65	DN80	DN100	DN125	DN150	DN200	DN250	DN300	DN350	DN400
PN16-L 型	18	22	31	42	62	88	126	192	308	572	858	1320	1738	2805	4103	6138
PN16-T 型	34	42	59	80	118	167	239	365	585	1087	1630	2508	3302	5329	7796	11662
PN25-L 型	20	25	40	75	83	115	176	264	396	803	1320	2035	2453	4015	5880	8899
PN25-T 型	38	47	76	142	158	218	334	502	752	1526	2508	3866	4660	7628	11172	16900
PN40-L 型	22	33	59	112	132	165	264	451	676	1265	2156	2750	3619	6006	8816	13508
PN40-T 型	42	63	112	213	251	313	502	857	1284	2403	4096	5225	6876	11411	16750	25665
PN63-L 型	27	46	77	165	211	286	429	726	1023	2090	3245	4620	6116	9427	12738	22715
PN63-T 型	51	87	146	313	400	543	815	1379	1944	3971	6165	8778	11620	17900	24200	43100
PN100-L 型	33	60	115	213	330	286	517	946	1452	2178	3157	5874	10186	14982	19700	35200
PN100-T 型	63	114	218	405	627	543	982	1797	2759	4138	5998	11160	19353	28466	37400	66800
PN160-L 型	42	93	170	297	429	429	781	1419	2145	3432	4928	8635	17050	24700	33000	59800
PN160-T 型	80	178	323	564	815	815	1484	2696	4075	6521	9363	16406	32395	46900	62700	113600
CL150-L 型	19	23	37	62	68	103	143	225	341	671	1078	1595	2035	3685	5192	7843
CL150-T 型	36	44	70	118	129	196	272	427	648	1275	2048	3030	3866	6999	9865	14902
CL300-L 型	24	35	71	129	154	235	324	605	825	1628	2651	3971	4917	7645	10296	18579
CL300-T 型	46	66	125	245	293	446	616	1150	1567	3093	5037	7545	9342	14525	19562	35300
CL600-L 型	33	60	115	213	330	286	517	946	1452	2178	3157	5874	10186	14982	19700	35200
CL600-T 型	63	114	218	405	627	543	982	1797	2759	4138	5998	11160	19353	28466	37400	66800
CL900-L 型	42	93	170	297	429	429	781	1419	2145	3432	4928	8635	17050	24700	33000	59800
CL900-T 型	80	178	323	564	815	815	1484	2696	4075	6521	9363	16406	32395	46900	62700	113600

注：黑色部分为浮动式三通四通球阀力矩表，红色部分为固定式三通四通球阀力矩表。

Note: The black part is the torque table of the floating three-way four-way ball valve, and the red part is the torque table of the fixed three-way four-way ball valve.

Three Way Flange Ball Valve

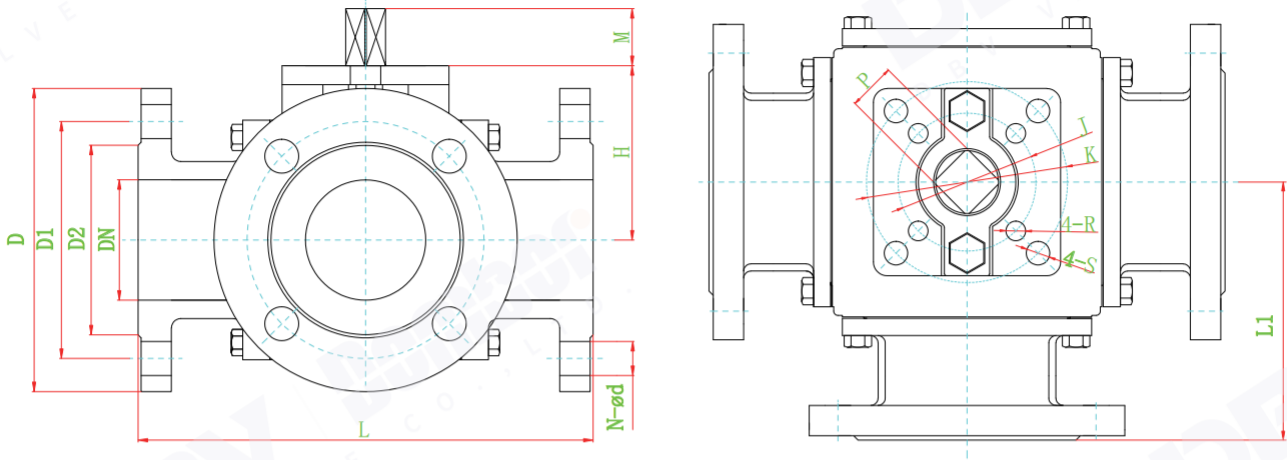

GB PN16 主要外形尺寸表 Main dimensions table

Unit : mm

SIZE	L	L1	D2	D1	D	N-ø d	M	H	J	K	P	R	S
DN15	150	75	45	65	95	4-ø 14	13	58	42	50	11	6	7
DN20	160	80	58	75	105	4-ø 14	16	61	50	70	14	7	9
DN25	180	90	68	85	115	4-ø 14	16	72	50	70	14	7	9
DN32	200	100	78	100	140	4-ø 18	16	81	50	70	14	7	9
DN40	220	110	88	110	150	4-ø 18	19	103	70	102	17	9	11
DN50	240	120	102	125	165	4-ø 18	19	113	70	102	17	9	11
DN65	260	130	122	145	185	8-ø 18	19	120	70	102	17	9	11
DN80	280	140	138	160	200	8-ø 18	24	162	125	140	22	14	18
DN100	320	160	158	180	220	8-ø 18	24	184	125	140	22	14	18
DN125	380	190	188	210	250	8-ø 18	29	215	140	165	27	18	22
DN150	440	220	212	240	285	8-ø 22	29	250	140	165	27	18	22
DN200	550	275	268	295	340	12-ø 22	38	334		165	36		22
DN250	670	335	320	355	405	12-ø 26		380		165			
DN300	720	360	378	410	460	12-ø 26		405		165			
DN350	890	445	438	470	520	16-ø 26		450		254			
DN400	1000	500	490	525	580	16-ø 30		490		254			

Three Way Flange Ball Valve

GB PN25~40 主要外形尺寸表 Main dimensions table

Unit : mm

SIZE	L	L1	D2	D1	D	N-ø d	M	H	J	K	P	R	S
DN15	150	75	45	65	95	4-ø 14	13	58	42	50	11	6	7
DN20	160	80	58	75	105	4-ø 14	16	61	50	70	14	7	9
DN25	180	90	68	85	115	4-ø 14	16	72	50	70	14	7	9
DN32	200	100	78	100	140	4-ø 18	16	81	50	70	14	7	9
DN40	220	110	88	110	150	4-ø 18	19	103	70	102	17	9	11
DN50	240	120	102	125	165	4-ø 18	19	113	70	102	17	9	11
DN65	290	145	122	145	185	8-ø 18	19	120	70	102	17	9	11
DN80	310	155	138	160	200	8-ø 18	24	162	125	140	22	14	18
DN100	350	175	162	190	235	8-ø 22	24	184	125	140	22	14	18
DN125	400	200	188	220	270	8-ø 26	29	215	140	165	27	18	22
DN150	480	240	218	250	300	8-ø 26	29	250	140	165	27	18	22
DN200	PN25	600	300	268	310	365	12-ø 26	38	334		165	36	22
	PN40	600	300	285	320	375	12-ø 30	38	334		165	36	22
DN250	PN25	730	365	335	370	425	12-ø 30		380		165		
	PN40	730	365	345	385	450	12-ø 33		380		165		
DN300	PN25	850	425	395	430	485	16-ø 30		405		165		
	PN40	850	425	410	450	515	16-ø 33		405		165		
DN350	PN25	980	490	450	490	555	16-ø 33		450		254		
	PN40	980	490	465	510	580	16-ø 36		450		254		
DN400	PN25	1100	550	505	550	620	16-ø 36		490		254		
	PN40	1100	550	535	585	660	16-ø 39		490		254		

ASME CLASS150 主要外形尺寸表 Main dimensions table

Unit : mm

SIZE	L	L1	D2	D1	D	N-ø d	M	H	J	K	P	R	S
NPS1/2	150	75	34.9	60.3	90	4-ø 16	13	58	42	50	11	6	7
NPS3/4	160	80	42.9	69.9	100	4-ø 16	16	61	50	70	14	7	9
NPS1	180	90	50.8	79.4	110	4-ø 16	16	72	50	70	14	7	9
NPS1-1/4	200	100	63.5	88.9	115	4-ø 16	16	81	50	70	14	7	9
NPS1-1/2	220	110	73.0	98.4	125	4-ø 16	19	103	70	102	17	9	11
NPS2	240	120	92.1	120.7	150	4-ø 19	19	113	70	102	17	9	11
NPS2-1/2	260	130	104.8	139.7	180	4-ø 19	19	120	70	102	17	9	11
NPS3	280	140	127.0	152.4	190	4-ø 19	24	162	125	140	22	14	18
NPS4	320	160	157.2	190.5	230	8-ø 19	24	184	125	140	22	14	18
NPS5	380	190	185.7	215.9	255	8-ø 22	29	215	140	165	27	18	22
NPS6	440	220	215.9	241.3	280	8-ø 22	29	250	140	165	27	18	22
NPS8	550	275	269.9	298.5	345	8-ø 22	38	334		165	36		22
NPS10	670	335	323.8	362.0	405	12-ø 26		380		165			
NPS12	720	360	381.0	413.8	485	12-ø 26		405		165			
NPS14	890	445	412.8	476.3	535	12-ø 29		450		254			
NPS16	1000	500	469.9	539.8	595	16-ø 29		490		254			

Three Way Flange Ball Valve

ASME CLASS300 主要外形尺寸表 Main dimensions table

Unit : mm

SIZE	L	L1	D2	D1	D	N- ϕ d	M	H	J	K	P	R	S
NPS1/2	150	75	34.9	66.7	95	4- ϕ 16	13	58	42	50	11	6	7
NPS3/4	160	80	42.9	82.6	115	4- ϕ 19	16	61	50	70	14	7	9
NPS1	180	90	50.8	88.9	125	4- ϕ 19	16	72	50	70	14	7	9
NPS1-1/4	200	100	63.5	98.4	135	4- ϕ 19	16	81	50	70	14	7	9
NPS1-1/2	220	110	73.0	114.3	155	4- ϕ 22	19	103	70	102	17	9	11
NPS2	240	120	92.1	127.0	165	8- ϕ 19	19	113	70	102	17	9	11
NPS2-1/2	290	145	104.8	149.2	190	8- ϕ 22	19	120	70	102	17	9	11
NPS3	310	155	127.0	168.3	210	8- ϕ 22	24	162	125	140	22	14	18
NPS4	350	175	157.2	200.0	255	8- ϕ 22	24	184	125	140	22	14	18
NPS5	400	200	185.7	235.0	280	8- ϕ 22	29	215	140	165	27	18	22
NPS6	480	240	215.9	269.9	320	12- ϕ 22	29	250	140	165	27	18	22
NPS8	600	300	269.9	330.2	380	12- ϕ 26	38	334		165	36		22
NPS10	730	365	323.8	387.4	445	16- ϕ 29		380		165			
NPS12	850	425	381.0	450.8	520	16- ϕ 32		405		165			
NPS14	980	490	412.8	514.4	585	20- ϕ 32		450		254			
NPS16	1100	550	469.9	571.5	650	20- ϕ 35		490		254			

JIS 10K 主要外形尺寸表 Main dimensions table

Unit : mm

SIZE	L	L1	D2	D1	D	N- ϕ d	M	H	J	K	P	R	S
15A	150	75	51	70	95	4- ϕ 15	13	58	42	50	11	6	7
20A	160	80	56	75	100	4- ϕ 15	16	61	50	70	14	7	9
25A	180	90	67	90	125	4- ϕ 19	16	72	50	70	14	7	9
32A	200	100	76	100	135	4- ϕ 19	16	81	50	70	14	7	9
40A	220	110	81	105	140	4- ϕ 19	19	103	70	102	17	9	11
50A	240	120	96	120	155	4- ϕ 19	19	113	70	102	17	9	11
65A	260	130	116	140	175	4- ϕ 19	19	120	70	102	17	9	11
80A	280	140	126	150	185	8- ϕ 19	24	162	125	140	22	14	18
100A	320	160	151	175	210	8- ϕ 19	24	184	125	140	22	14	18
125A	380	190	182	210	250	8- ϕ 23	29	215	140	165	27	18	22
150A	440	220	212	240	280	8- ϕ 23	29	250	140	165	27	18	22
200A	550	275	262	290	330	12- ϕ 23	38	334		165	36		22
250A	670	335	324	355	400	12- ϕ 25		380		165			
300A	720	360	368	400	445	16- ϕ 25		405		165			
350A	890	445	413	445	490	16- ϕ 25		450		254			
400A	1000	500	475	510	560	16- ϕ 27		490		254			

Pneumatic Three-way Flange Ball Valve

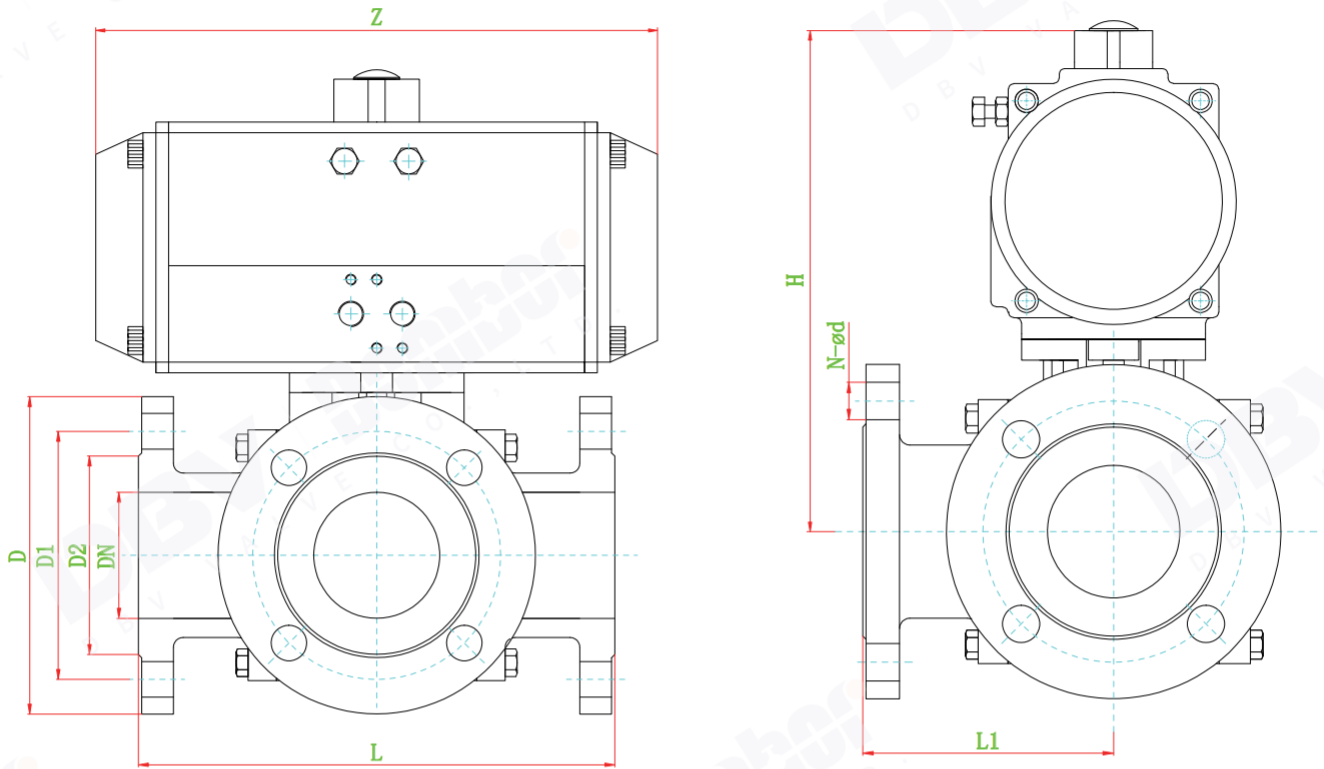

GB PN16 主要外形尺寸表 Main dimensions table

Unit : mm

SIZE	L	L1	D2	D1	D	N-ø d	双作用 (DA)		单作用 (SR)	
							H	Z	H	Z
DN15	150	75	46	65	95	4-ø 14	150	147	170	168
DN20	160	80	56	75	105	4-ø 14	170	168	190	204
DN25	180	90	65	85	115	4-ø 14	190	184	210	262
DN32	200	100	76	100	140	4-ø 18	210	204	235	268
DN40	220	110	84	110	150	4-ø 18	240	262	290	296
DN50	240	120	99	125	165	4-ø 18	270	268	315	390
DN65	260	130	118	145	185	8-ø 18	215	296	360	454
DN80	280	140	132	160	200	8-ø 18	390	454	420	525
DN100	320	160	156	180	220	8-ø 18	450	525	475	532
DN125	380	190	184	210	250	8-ø 18	500	532	530	610
DN150	440	220	211	240	285	8-ø 22	570	610	606	722
DN200	550	275	266	295	340	12-ø 22	690	722	726	830

Electric Three-way Flange Ball Valve

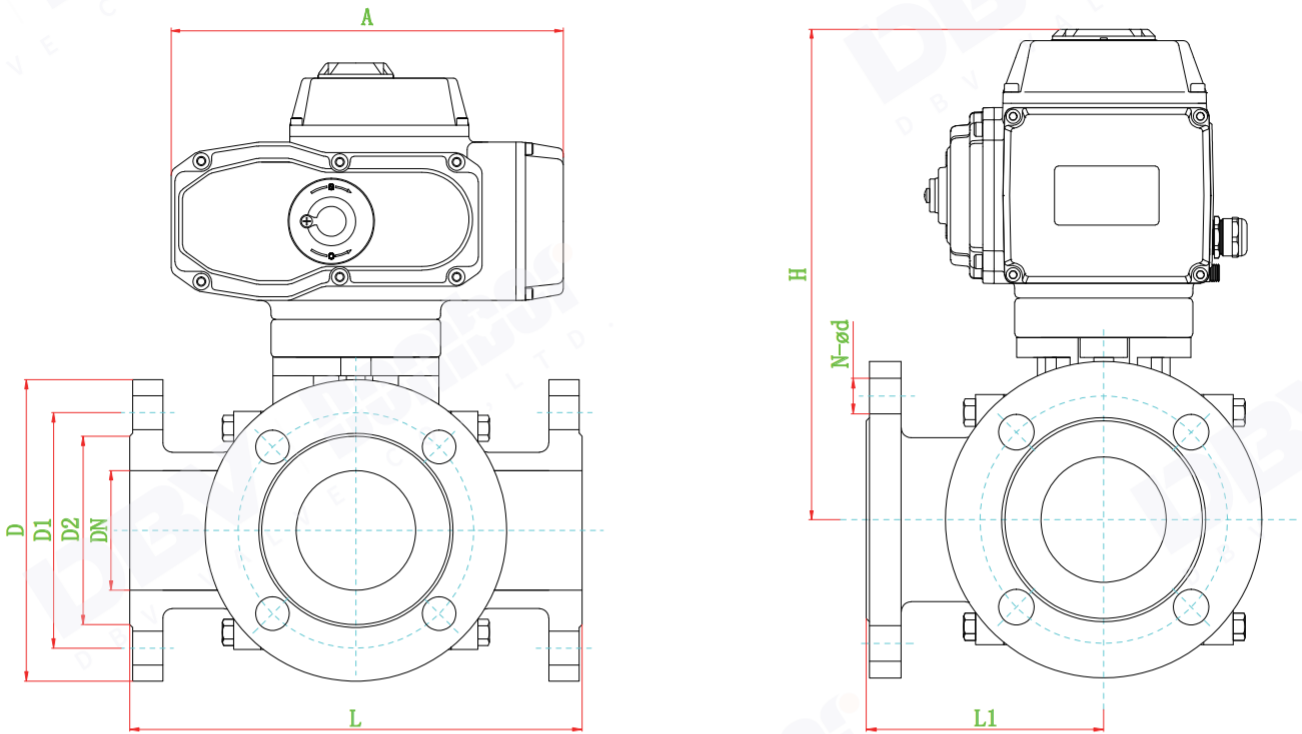

GB PN16 主要外形尺寸表 Main dimensions table

Unit : mm

SIZE	L	L1	D2	D1	D	N-ø d	A	H	SIZE
DN15	150	75	46	65	95	4-ø 14	165	200	SPD05
DN20	160	80	56	75	105	4-ø 14	165	210	SPD05
DN25	180	90	65	85	115	4-ø 14	212	240	SPD10
DN32	200	100	76	100	140	4-ø 18	212	250	SPD10
DN40	220	110	84	110	150	4-ø 18	259	310	SPD20
DN50	240	120	99	125	165	4-ø 18	259	320	SPD20
DN65	260	130	118	145	185	8-ø 18	259	335	SPD40
DN80	280	140	132	160	200	8-ø 18	259	365	SPD60
DN100	320	160	156	180	220	8-ø 18	284	420	SPD100
DN125	380	190	184	210	250	8-ø 18	284	440	SPD200
DN150	440	220	211	240	285	8-ø 22	284	470	SPD200
DN200	550	275	266	295	340	12-ø 22	500	700	SPD400

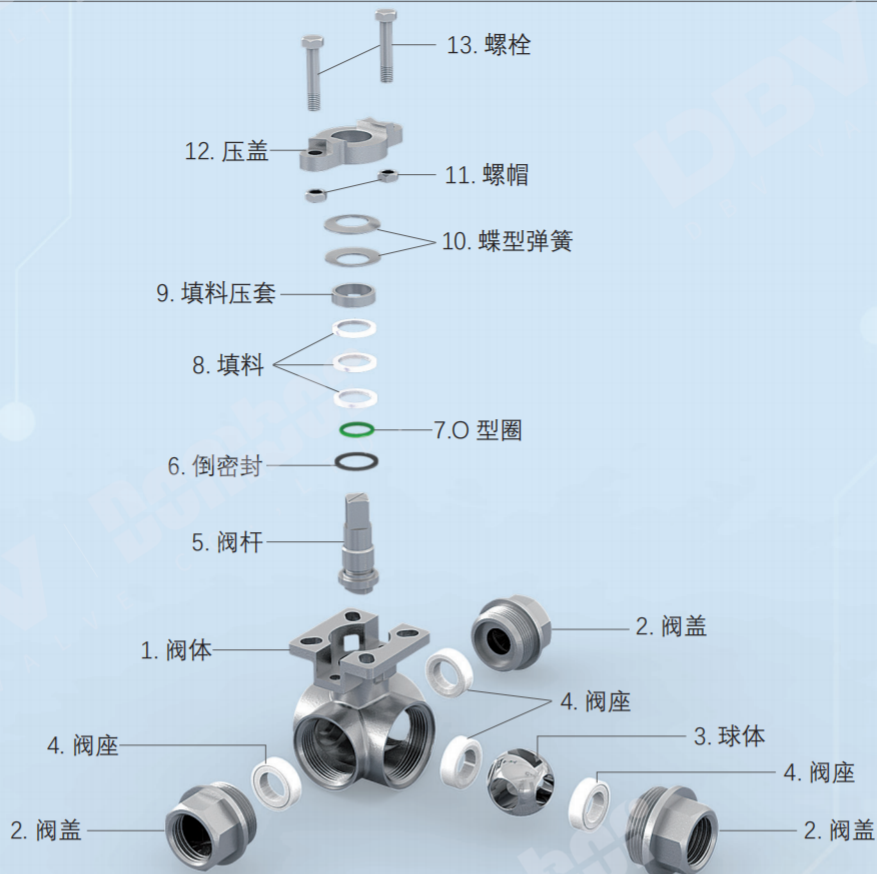

主要零件材料 Main parts materials

序号 Serial number	零件名称 Part Name	材料 material
1	阀体 Body	CF8、CF8M、CF3M
2	阀盖 Bonnet	CF8、CF8M、CF3M
3	球体 Ball body	SS304、SS316、SS316L
4	阀座 Seat	PTFE、PPL
5	阀杆 Stem	SS304、SS316、SS316L
6	倒密封 Inverted seal	PTFE、PPL
7	O型圈 O-ring	氟橡胶 VITON
8	填料 Filler	PTFE、PPL
9	填料压套 Filling clamping ring	SS304
10	蝶形弹簧 Butterfly spring	SS304
11	螺帽 NUT	SS304
12	压盖 Gland of valve	CF8
13	螺栓 Screw	SS304

Tee Thread Ball Valve

产品技术 参数 Product Specifications

公称压力 Nominal pressure	1000WOG
公称通径 Nominal diameter	DN15~DN50
连接方式 Connection method	BSPT、BSP、NPT、DIN、JIS、RC、G
阀体材料 Body material	CF8、CF8M、CF3M 等
阀座形式 Valve seat form	PTFE、PPL
适用温度 proper temperature	软阀座：-20~ + 200C° Soft seat: -20~ + 200C°
泄漏等级 Leakage level	ANSI VI
检测标准 Testing standards	GB/T13927、API598
操作方式 Operation method	手动、气动、电动等 Manual, pneumatic, electric, etc.
可选项 Optional	防静电设计、禁油处理、禁铜处理、球面特殊处理 Anti-static design、oil-free treatment、Copper Prohibition、Spherical special treatment

产品结构特点

Product structure design features

阀杆防吹出结构设计（见图 1）

阀杆防吹出结构设计，下端大上端小的阀杆在上端盖和螺丝的定位下，即使在阀腔异常的情况下，也能保证阀杆不会被介质吹出。

Valve stem anti-blowing structure design (see picture 1)

Valve stem anti-blowing structure design, the lower end is larger and the upper end is smaller Under the positioning of the upper end cover and screws, even in the valve cavity is abnormal In the case of, it can also ensure that the valve stem will not be blown out by the medium.



图 1 (picture 1)

防静电设计（见图 2）

固定球阀通过防静电设计使球体、阀杆、阀体形成静电通道。从而将球体与阀座开关过程中由于摩擦产生的静电通过阀体引到大地，防止静电火花可能引起的火灾或爆炸危险。

Anti-static design (See picture 2)

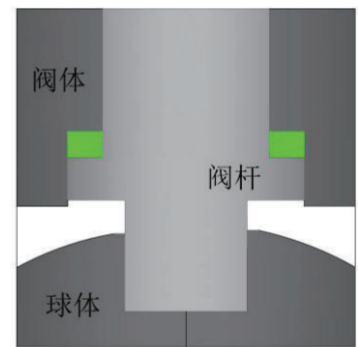
The fixed ball valve adopts anti-static design to make the ball, stem and valve The body forms an electrostatic channel. So that the ball and the seat are switched During the process, static electricity generated by friction is led to the ground through the valve body, Prevent the risk of fire or explosion caused by static sparks.



图 2 (picture 2)

KV 值 rated

SIZE	DN15	DN20	DN25	DN32	DN40	DN50
Kv	13	21	38	72	112	170

软密封力矩表 Soft seal torque table

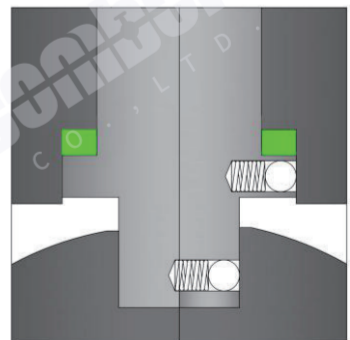
N.m

SIZE	DN15	DN20	DN25	DN32	DN40	DN50
PN16	4	6	10	20	26	32
PN25	7	10	14	22	30	36
PN40	11	14	20	48	60	70
PN63	16	30	60	100	130	160

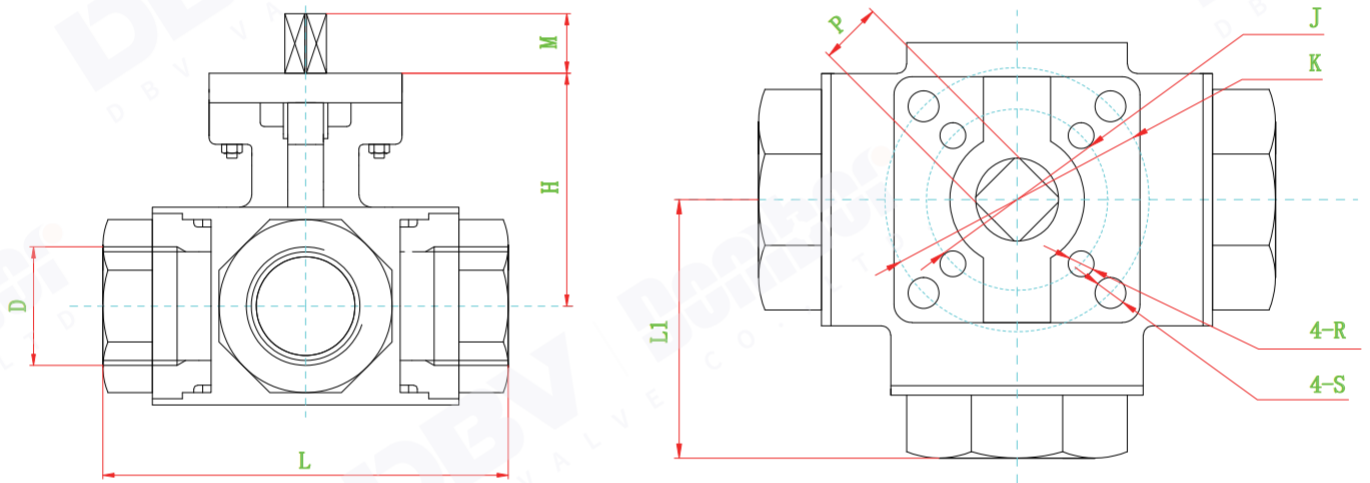

1000WOG 主要外形尺寸表 Main dimensions table

Unit : mm

SIZE	D	L	L1	H	M	P	J	K	R	S
DN15 1/2"	12	79	39.5	48.5	10	9	42	50	6	7
DN20 3/4"	16	86	43	53.5	10	9	42	50	6	7
DN25 1"	20	101	50.5	60	13	11	42	50	6	7
DN32 1-1/4"	25	114	57	67.5	13	11	42	50	6	7
DN40 1-1/2"	32	136	68	74	16	14	50	70	7	9
DN50 2"	38	152	76	82.5	16	14	50	70	7	9

Pneumatic/electric Tee Thread Ball Valve

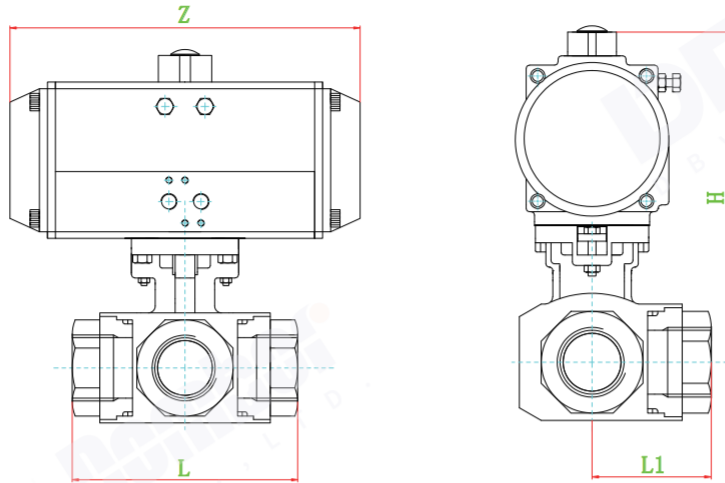

1000WOG 主要外形尺寸表 Main dimensions table

Unit : mm

SIZE		L	L1	双作用 (DA)		单作用 (SR)	
				H	Z	H	Z
DN15	1/2"	75	37.5	135	147	150	168
DN20	3/4"	85	42.5	160	168	170	184
DN25	1"	100	50	180	184	190	204
DN32	1-1/4"	115	57.5	190	204	200	262
DN40	1-1/2"	124	62	210	262	225	268
DN50	2"	147	75	230	268	265	296

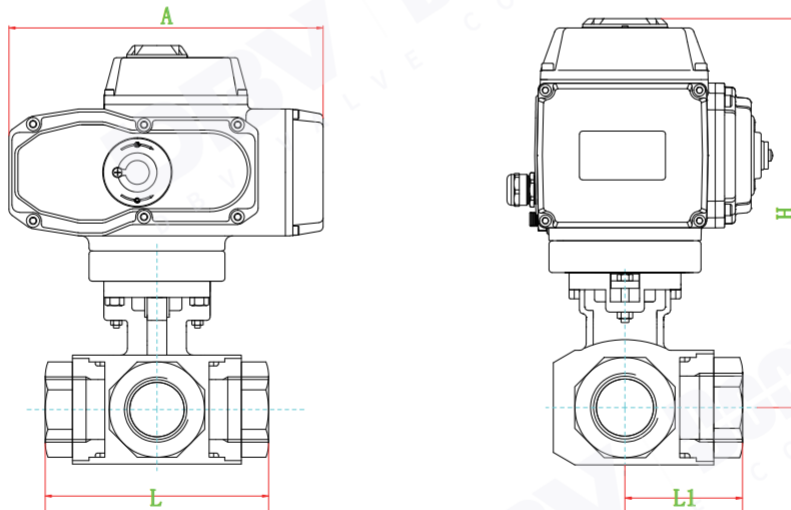

1000WOG 主要外形尺寸表 Main dimensions table

Unit : mm

SIZE		L	L1	A	H
DN15	1/2"	75	37.5	165	180
DN20	3/4"	85	42.5	165	190
DN25	1"	100	50	165	230
DN32	1-1/4"	115	57.5	212	240
DN40	1-1/2"	124	62	212	275
DN50	2"	147	75	259	285

Four Way Double L Ball Valve

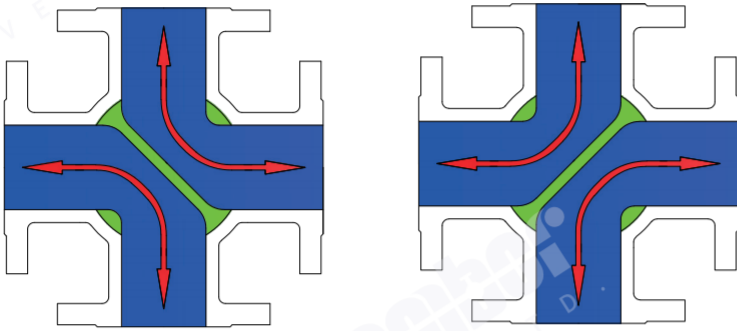

流向图

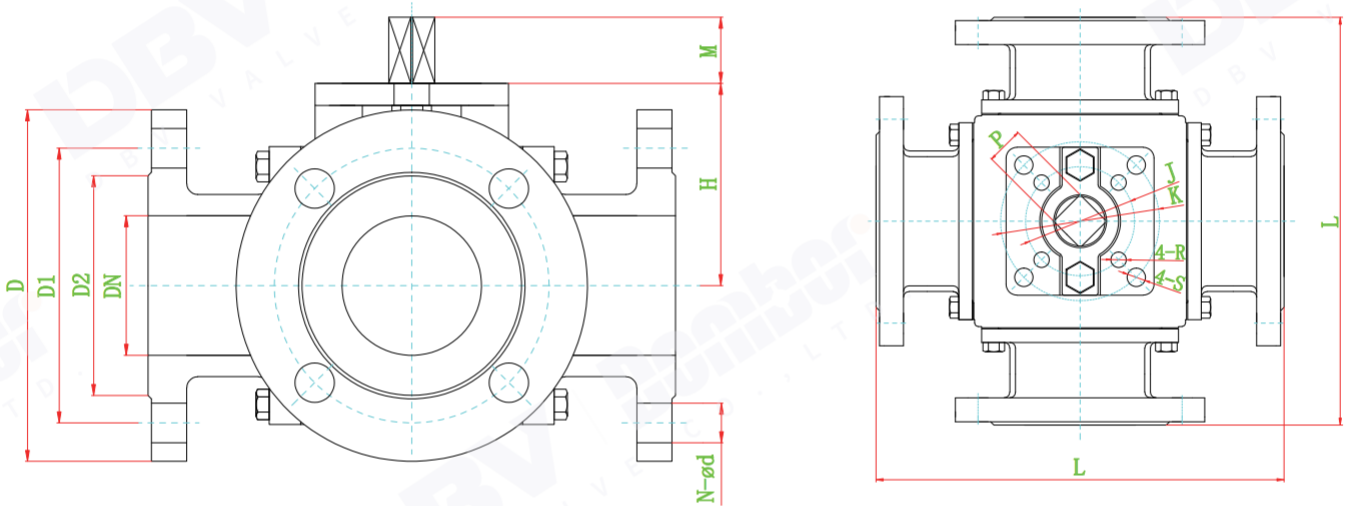
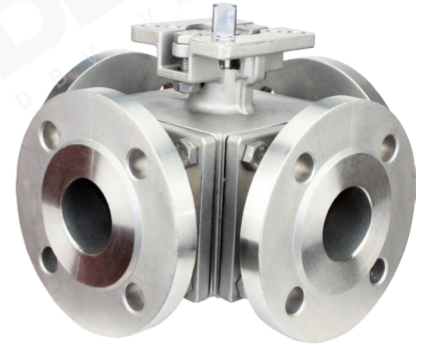

GB PN16 主要外形尺寸表 Main dimensions table

Unit : mm

SIZE	L	D2	D1	D	N-ø d	M	H	J	K	P	R	S
DN15	150	45	65	95	4-ø 14	13	58	42	50	11	6	7
DN20	160	58	75	105	4-ø 14	16	61	50	70	14	7	9
DN25	180	68	85	115	4-ø 14	16	72	50	70	14	7	9
DN32	200	78	100	140	4-ø 18	16	81	50	70	14	7	9
DN40	220	88	110	150	4-ø 18	19	103	70	102	17	9	11
DN50	240	102	125	165	4-ø 18	19	113	70	102	17	9	11
DN65	260	122	145	185	8-ø 18	19	120	70	102	17	9	11
DN80	280	138	160	200	8-ø 18	24	162	125	140	22	14	18
DN100	320	158	180	220	8-ø 18	24	184	125	140	22	14	18
DN125	380	188	210	250	8-ø 18	29	215	140	165	27	18	22
DN150	440	212	240	285	8-ø 22	29	250	140	165	27	18	22
DN200	550	268	295	340	12-ø 22	38	334		165	36		22

Four Way Three Position Ball Valve

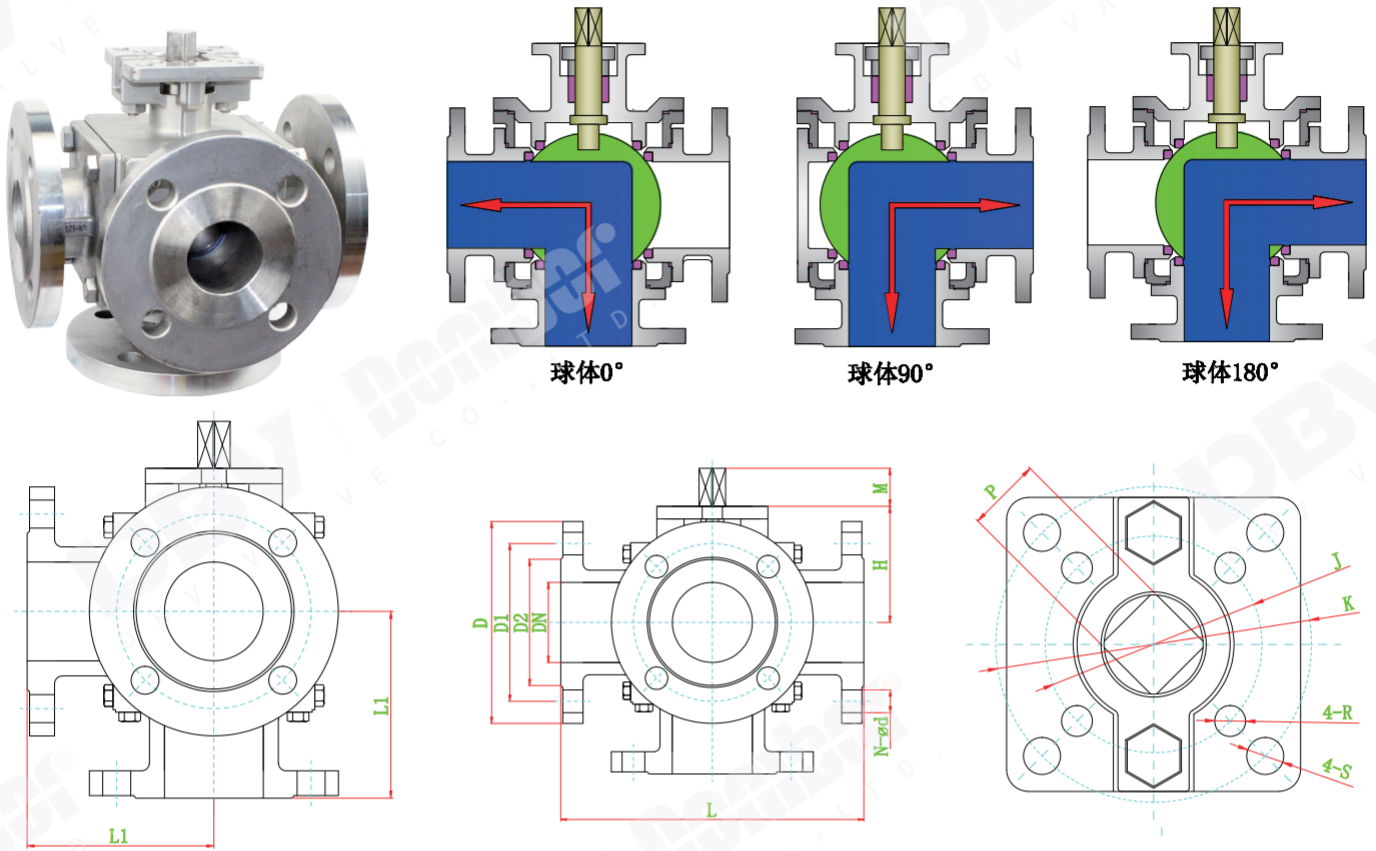

GB PN16 主要外形尺寸表 Main dimensions table

Unit : mm

SIZE	L	L1	D2	D1	D	N-ø d	M	H	J	K	P	R	S
DN15	150	75	45	65	95	4-ø 14	13	58	42	50	11	6	7
DN20	160	80	58	75	105	4-ø 14	16	61	50	70	14	7	9
DN25	180	90	68	85	115	4-ø 14	16	72	50	70	14	7	9
DN32	200	100	78	100	140	4-ø 18	16	81	50	70	14	7	9
DN40	220	110	88	110	150	4-ø 18	19	103	70	102	17	9	11
DN50	240	120	102	125	165	4-ø 18	19	113	70	102	17	9	11
DN65	260	130	122	145	185	8-ø 18	19	120	70	102	17	9	11
DN80	280	140	138	160	200	8-ø 18	24	162	125	140	22	14	18
DN100	320	160	158	180	220	8-ø 18	24	184	125	140	22	14	18
DN125	380	190	188	210	250	8-ø 18	29	215	140	165	27	18	22
DN150	440	220	212	240	285	8-ø 22	29	250	140	165	27	18	22
DN200	550	275	268	295	340	12-ø 22	38	334		165	36		22

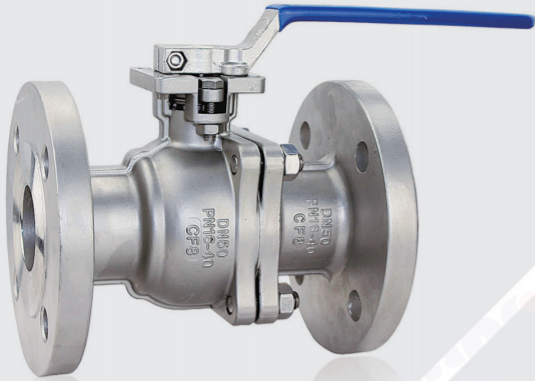

手动法兰球阀

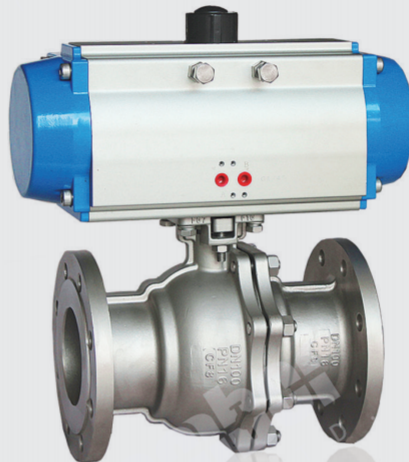

气动法兰球阀

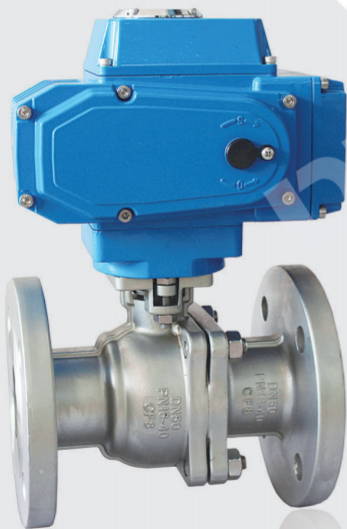

电动法兰球阀

HIGH PLATFORM
FLOATING
BALL VALVE

高平台浮动球阀 >

产品概述

该系列 O 型球阀具有流通能力大、结构紧凑、密封性能好、寿命长等特点，经济实用、易于维护。广泛应用于石油、化工、天然气、电力、冶金、食品、制药等要求严密切断的场合，也可适用于水、蒸汽、油品、液化气、天然气、煤气等介质。另外可根据客户的需求选择防火型、特殊硬化处理型，提供更安全、更广泛的应用。

Product description

This series of O-type ball valves have the characteristics of large circulation capacity, compact structure, good sealing performance, long life, etc., economical and practical, easy to maintain. It is widely used in petroleum, chemical, natural gas, electric power, metallurgy, food, pharmaceutical and other occasions with strict requirements. It can also be applied to water, steam, oil, liquefied gas, natural gas, coal gas and other media. In addition, fire-proof type and special hardening type can be selected according to the needs of customers to provide safer and wider applications.

产品特点

1. 阀体采用精密铸造或锻造，结构紧凑、外观美观。O型球阀阀芯、阀杆做旋转运动，转动阀芯时阀芯阀座始终紧密接触，具有极强的剪切能力；
2. 可设计阀座由圆柱弹簧或蝶簧预载，具有自动补偿、自密封和阀门中空自动泄压功能，适用于高温、高压场合；
3. 球阀旋转设计能够保证球阀运行平稳，减少操作扭矩；
4. 双关双断设计保证球阀完全开启和完全关闭。多种密封结构可选择，保证使用寿命及可靠性。密封结构可选用阀前阀座密封（推荐），阀后阀座密封，阀前阀后同时密封（特定工况使用）。密封有软硬密封可选择，密封表面可硬化处理，适用于多种工况；
5. 阀门中空自动泄压设计，阀门体腔停留介质温度升高而引起异常升压时，不需通过安全阀，而仅靠阀座功能就可自动泄压，提高阀门在输送液体介质时安全性；
6. 紧急注脂救护，在有些特殊场合，由于介质中的异物或火灾造成阀座密封意外失效，注脂阀提供了与注脂枪快速连接，方便快捷地将密封脂注入到阀座密封部位，缓解泄漏；
7. 球阀有防火结构、防静电结构、防阀杆吹出结构设计；
8. 加长型阀杆设计，可适用于低温场合。

Features

1. The valve body adopts precision casting or forging, with compact structure and beautiful appearance. The spool and stem of the O-type ball valve make a rotating movement. When the spool is turned, the valve seat and the valve seat are always in close contact and have a strong shearing ability;
2. The valve seat can be designed to be preloaded by cylindrical spring or butterfly spring, with automatic compensation, self-sealing and automatic pressure relief in the valve cavity, suitable for high temperature and high pressure occasions;
3. The rotating design of the valve ball can ensure the smooth operation of the valve ball and reduce the operating torque;
4. Double-closing and double-breaking design ensures that the valve ball is fully opened and completely closed. Various sealing structures are available to ensure the service life and reliability. The sealing structure can choose the front seat sealing (recommended), the rear seat sealing, and the front sealing at the same time (used in specific working conditions). The seal has soft and hard seals, and the sealing surface can be hardened, which is suitable for a variety of working conditions;
5. The automatic pressure relief design of the valve middle cavity. When the medium temperature of the valve body cavity rises and causes abnormal pressure increase, it does not need to pass the safety valve, but can automatically relieve pressure only by the function of the valve seat, improving the safety of the valve when conveying liquid medium.
6. Emergency grease injection rescue, in some special occasions, due to foreign objects in the medium or fire caused by the accidental failure of the valve seat seal, the grease injection valve provides a quick connection to the grease injection gun, which is convenient and quick to inject the sealing grease into the seat sealing part to mitigate the leak;
7. The ball valve has fireproof structure, antistatic structure, and anti-stem blowout structure design;
8. The elongated stem design is suitable for low temperature applications.

High Platform Floating Ball Valve

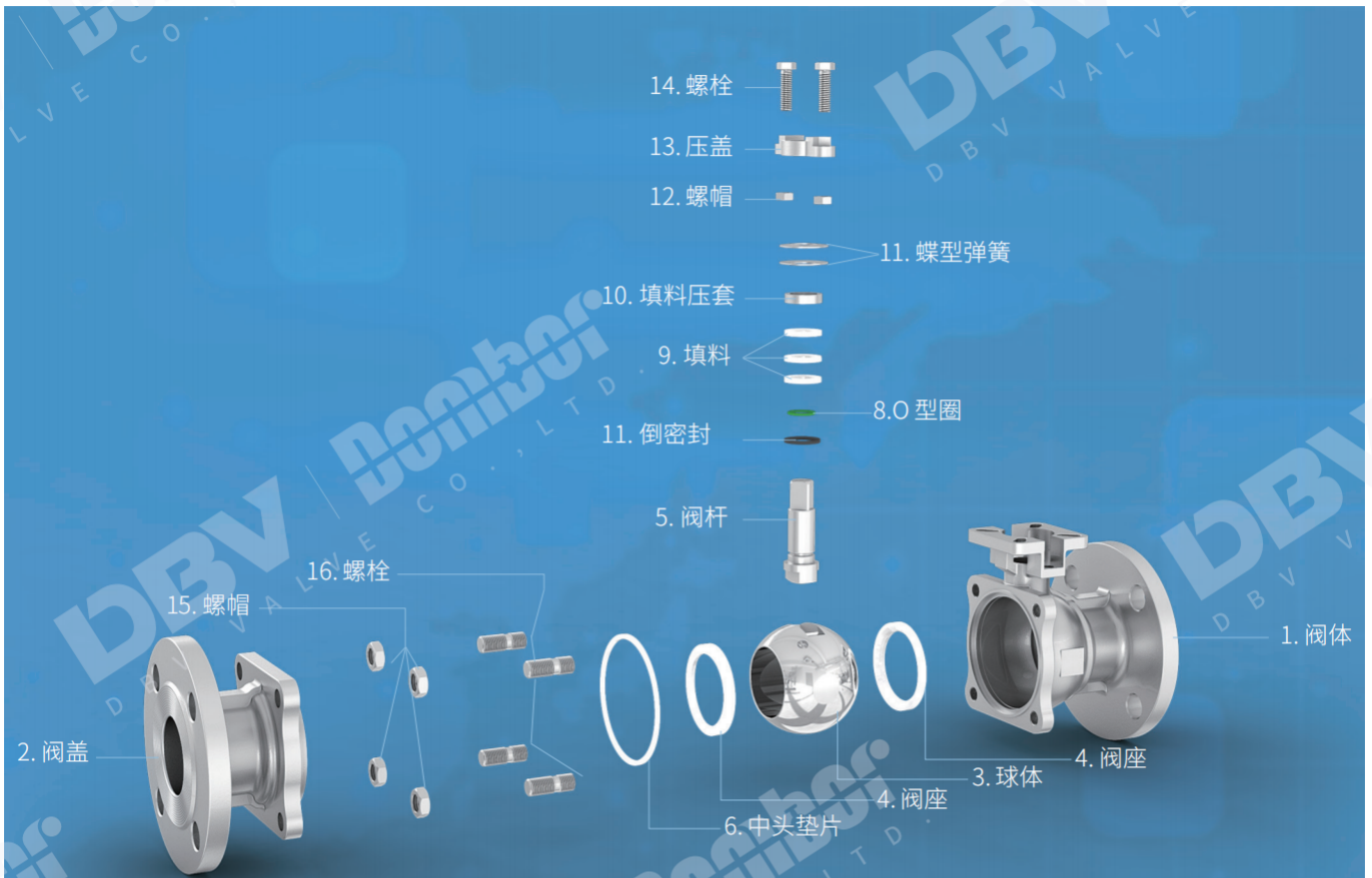

主要零件材料 Main parts materials

NO.	零件名称 PART NAME	材料 MATERIAL
1	阀体 Body	WCB、CF8、CF8M、CF3M 等
2	阀盖 Bonnet	WCB、CF8、CF8M、CF3M 等
3	球体 Ball body	SS304、SS316、SS316L、SS316L + STL 等
4	阀座 Seat	PTFE、PPL、金属密封等 (Metal seal, etc.)
5	阀杆 Stem	304、SS316、316L、17-4PH、S20910
6	中头垫片 Middle head gasket	PTFE、PPL、金属垫片 (Metal gasket)
7	倒密封 Inverted seal	PTFE、PPL、不锈钢缠绕石墨 (Stainless steel spiral graphite)
8	O 型圈 O-ring	氟橡胶 (VITON)
9	填料 Filler	PTFE、PPL、柔性石墨 (Flexible graphite)
10	填料压套 Filling clamping ring	SS304
11	蝶形弹簧 Butterfly spring	SS304
12	螺帽 NUT	2H、SS304
13	压盖 Gland of valve	CF8
14	螺栓 Screw	B7、SS304
15	螺帽 NUT	2H、SS304
16	螺栓 Screw	B7、SS304

High Platform Floating Ball Valve

产品技术 参数 Product Specifications

公称压力 Nominal pressure	PN1.6~42MPa、ANSI150LB~2500LB
公称通径 Nominal diameter (mm)	DN15~DN1000
连接形式 Connection Type	法兰 Flange、螺纹 Thread、对焊 Butt welding、承插焊 Socket welding
阀体材料 Body material	LCB、WCB、CF8、CF8M、CF3、CF3M 等
阀座形式 Valve seat form	软阀座、金属阀座（密封面硬化处理） Soft seat、metal seat (hardened sealing surface)
适用温度 proper temperature	软阀座：-20~ + 200C° 金属阀座：-196~ + 400C° Soft seat: -20~ + 200C° Metal seat: -196~ + 400C°
泄漏等级 Leakage level	ANSI VI
设计标准 design standards	GB/T12237、ASME B16.34
结构长度 Structure length	GB/T12221、ASME B16.10
检测标准 Testing standards	GB/T13927、API598
操作方式 Operation method	手动、气动、电动等 Manual、pneumatic、electric, etc.
可选项 Optional	防静电设计、防火设计、禁油处理、禁铜处理、球面特殊处理、按客户要求涂漆 Anti-static design、fire protection design、oil-free treatment、Copper Prohibition、Spherical special treatment、Customers request painting

产品结构特点

Product structure design features

阀杆防吹出结构设计（见图 1）

阀杆防吹出结构设计，下端大上端小的阀杆在上端盖和螺丝的定位下，即使在阀腔异常的情况下，也能保证阀杆不会被介质吹出。

Valve stem anti-blowing structure design (see picture 1)

Valve stem anti-blowing structure design, the lower end is larger and the upper end is smaller Under the positioning of the upper end cover and screws, even in the valve cavity is abnormal In the case of, it can also ensure that the valve stem will not be blown out by the medium.

防静电设计（见图 2）

固定球阀通过防静电设计使球体、阀杆、阀体形成静电通道。从而将球体与阀座开关过程中由于摩擦产生的静电通过阀体引到大地，防止静电火花可能引起的火灾或爆炸危险。

Anti-static design (See picture 2)

The fixed ball valve adopts anti-static design to make the ball, stem and valve The body forms an electrostatic channel. So that the ball and the seat are switched During the process, static electricity generated by friction is led to the ground through the valve body, Prevent the risk of fire or explosion caused by static sparks.



图 1 (picture 1)



图 2 (picture 2)

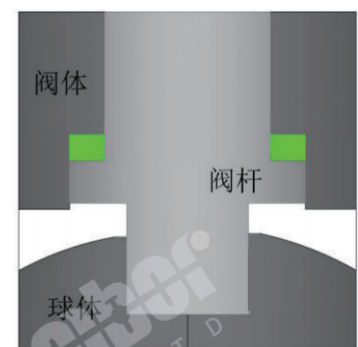

火烧前 (Before burning)

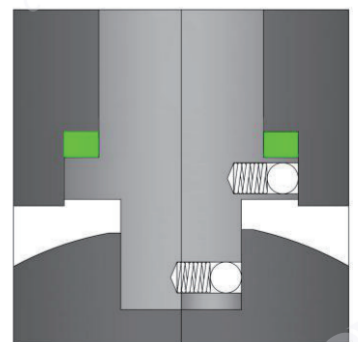

火烧后 (After burning)

防火结构设计

当发生火灾时，当非金属材料制作的阀座及密封件在高温下损坏后，特别设计的金属对金属辅助密封结构，有限的防止介质大量泄漏。

Fireproof structure design

In the event of a fire, when the valve seats and seals made of non-metallic materials are damaged at high temperatures, the specially designed metal-to-metal auxiliary sealing structure can prevent a large amount of medium leakage.

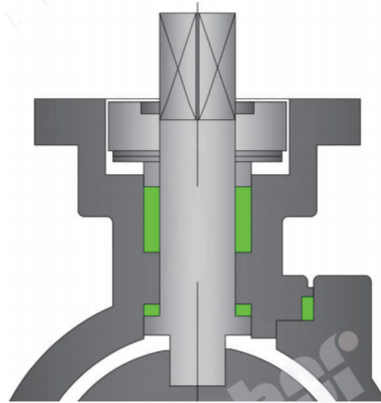

火烧前 (Before burning)

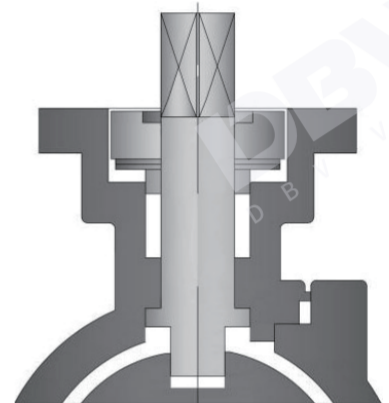

火烧后 (After burning)

KV 值 rated

SIZE	DN15	DN20	DN25	DN32	DN40	DN50	DN65	DN80	DN100	DN125	DN150	DN200	DN250	DN300	DN350	DN400
Kv	21	38	72	112	170	275	380	512	941	1451	2220	3590	5130	7360	8750	11800

软密封浮动球阀力矩表 Torque table of soft seal floating ball valve

N.m

SIZE	PN16	PN25	PN40	PN63	PN100	PN160	CL150	CL300	CL600	CL900	CL1500
DN15	3	5	7	15	19	30	5	8	19	24	32
DN20	5	7	10	30	35	56	7	12	35	44	55
DN25	10	11	24	50	68	108	13	20	68	85	115
DN32	13	15	30	65	100	160	18	29	100	125	145
DN40	16	18	35	80	130	208	22	38	130	163	171
DN50	25	30	50	100	190	304	30	60	190	238	296
DN65	50	60	100	200			60	110			
DN80	65	80	150	300			80	140			
DN100	125	140	250	400			130	260			
DN125	250	300	450				250	600			
DN150	340	400	585				470	930			
DN200	485	680	996				780	1550			

High Platform Floating Ball Valve

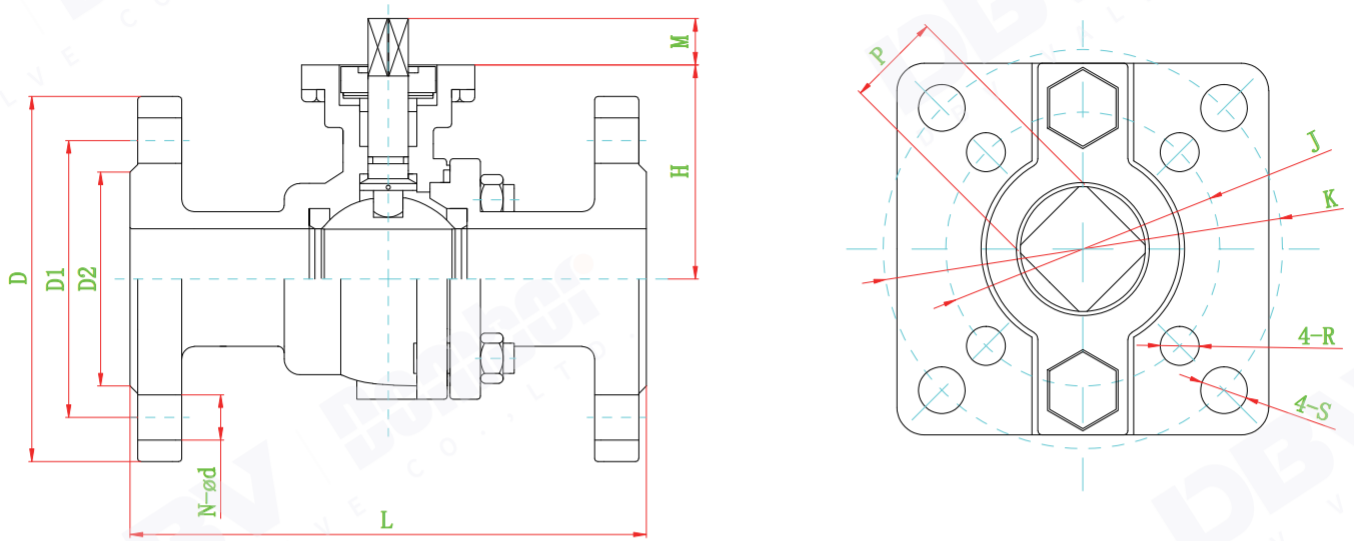

GB PN16~40 主要外形尺寸表 Main dimensions table

Unit : mm

SIZE	压力	L	D2	D1	D	N-ø d	M	H	J	K	P	R	S
DN15	PN16~40	130	45	65	95	4-ø 14	11	48	36	42	9	6	6
DN20	PN16~40	130	58	75	105	4-ø 14	11	53	36	42	9	6	6
DN25	PN16~40	140	68	85	115	4-ø 14	13	64	42	50	11	6	7
DN32	PN16~40	165	78	100	140	4-ø 18	13	71	42	50	11	6	7
DN40	PN16~40	165	88	110	150	4-ø 18	16	76	50	70	14	7	9
DN50	PN16~40	203	102	125	165	4-ø 18	16	85	50	70	14	7	9
DN65	PN16	222	122	145	185	8-ø 18	19	104	70	102	17	9	11
	PN25/PN40	241	122	145	185	8-ø 18	19	104	70	102	17	9	11
DN80	PN16	241	138	160	200	8-ø 18	19	114	70	102	17	9	11
	PN25/PN40	283	138	160	200	8-ø 18	19	114	70	102	17	9	11
DN100	PN16	305	158	180	220	8-ø 18	19	140	70	102	17	9	11
	PN25/PN40	305	162	190	235	8-ø 22	19	140	70	102	17	9	11
DN125	PN16	356	188	210	250	8-ø 18	24	183	102	125	22	11	14
	PN25/PN40	381	188	220	270	8-ø 26	24	183	102	125	22	11	14
DN150	PN16	394	212	240	285	8-ø 22	29	202	125	140	27	14	18
	PN25/PN40	403	218	250	300	8-ø 26	29	202	125	140	27	14	18
DN200	PN16	457	268	295	340	12-ø 22	29	253	125	140	27	14	18
	PN25	502	268	310	365	12-ø 26	29	253	140	165	27	18	22
	PN40	502	285	320	375	12-ø 30	29	253	140	165	27	18	22

High Platform Floating Ball Valve

ASMECLASS150 主要外形尺寸表 Main dimensions table

Unit : mm

SIZE	L	D2	D1	D	N-ø d	M	H	J	K	P	R	S
NPS1/2	108	34.9	60.3	90	4-ø 16	11	48	36	42	9	6	6
NPS3/4	117	42.9	69.9	100	4-ø 16	11	53	36	42	9	6	6
NPS1	127	50.8	79.4	110	4-ø 16	13	64	42	50	11	6	7
NPS1-1/4	140	63.5	88.9	115	4-ø 16	13	71	42	50	11	6	7
NPS1-1/2	165	73.0	98.4	125	4-ø 16	16	76	50	70	14	7	9
NPS2	178	92.1	120.7	150	4-ø 19	16	85	50	70	14	7	9
NPS2-1/2	190	104.8	139.7	180	4-ø 19	19	104	70	102	17	9	11
NPS3	203	127.0	152.4	190	4-ø 19	19	114	70	102	17	9	11
NPS4	229	157.2	190.5	230	8-ø 19	19	140	70	102	17	9	11
NPS5	356	185.7	215.9	255	8-ø 22	24	183	102	125	22	11	14
NPS6	394	215.9	241.3	280	8-ø 22	29	202	125	140	27	14	18
NPS8	457	269.9	298.5	345	8-ø 22	29	253	125	140	27	14	18

ASME CLASS300 主要外形尺寸表 Main dimensions table

Unit : mm

SIZE	L	D2	D1	D	N-ø d	M	H	J	K	P	R	S
NPS1/2	140	34.9	66.7	95	4-ø 16	11	48	36	42	9	6	6
NPS3/4	152	42.9	82.6	115	4-ø 19	11	53	36	42	9	6	6
NPS1	165	50.8	88.9	125	4-ø 19	13	64	42	50	11	6	7
NPS1-1/4	178	63.5	98.4	135	4-ø 19	13	71	42	50	11	6	7
NPS1-1/2	190	73.0	114.3	155	4-ø 22	16	76	50	70	14	7	9
NPS2	216	92.1	127.0	165	8-ø 19	16	85	50	70	14	7	9
NPS2-1/2	241	104.8	149.2	190	8-ø 22	19	104	70	102	17	9	11
NPS3	283	127.0	168.3	210	8-ø 22	19	114	70	102	17	9	11
NPS4	305	157.2	200.0	255	8-ø 22	19	140	70	102	17	9	11
NPS5	381	185.7	235.0	280	8-ø 22	24	183	102	125	22	11	14
NPS6	403	215.9	269.9	320	12-ø 22	29	202	125	140	27	14	18
NPS8	502	269.9	330.2	380	12-ø 26	29	253	140	165	27	18	22

JIS 10K 主要外形尺寸表 Main dimensions table

Unit : mm

SIZE	L	D2	D1	D	N-ø d	M	H	J	K	P	R	S
15A	108	51	70	95	4-ø 15	11	48	36	42	9	6	6
20A	117	56	75	100	4-ø 15	11	53	36	42	9	6	6
25A	127	67	90	125	4-ø 19	13	64	42	50	11	6	7
32A	140	76	100	135	4-ø 19	13	71	42	50	11	6	7
40A	165	81	105	140	4-ø 19	16	76	50	70	14	7	9
50A	178	96	120	155	4-ø 19	16	85	50	70	14	7	9
65A	190	116	140	175	4-ø 19	19	104	70	102	17	9	11
80A	203	126	150	185	8-ø 19	19	114	70	102	17	9	11
100A	229	151	175	210	8-ø 19	19	140	70	102	17	9	11
125A	356	182	210	250	8-ø 23	24	183	102	125	22	11	14
150A	394	212	240	280	8-ø 23	29	202	125	140	27	14	18
200A	457	262	290	330	12-ø 23	29	253	125	140	27	14	18

Pneumatic Flange Ball Valve

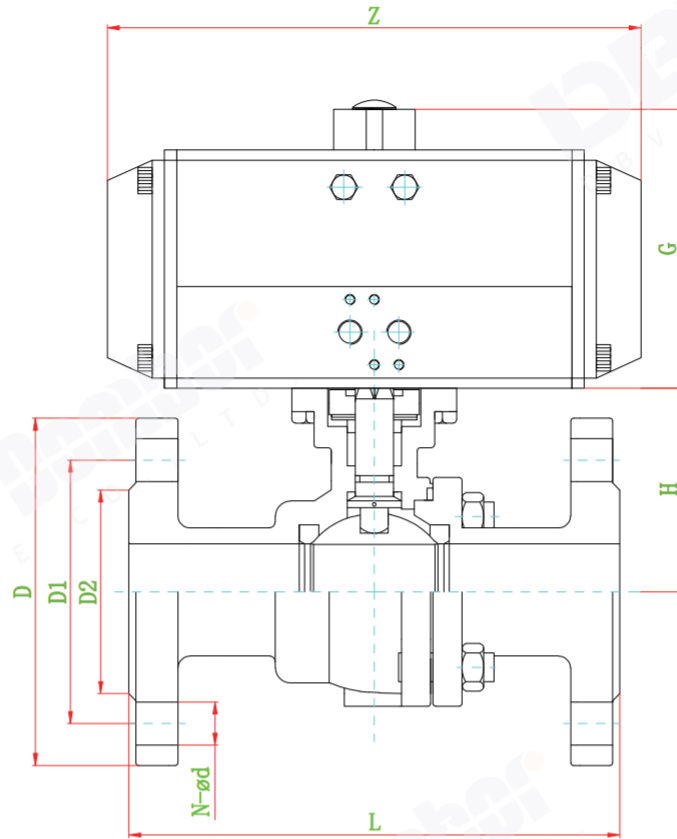

GB PN16 主要外形尺寸表 Main dimensions table

Unit : mm

SIZE	L	D2	D1	D	N-ø d	H	双作用 (DA)			单作用 (SR)		
							SIZE	G	Z	SIZE	G	Z
DN15	130	45	65	95	4-ø 14	48	SPA52	92	147	SPR52	92	147
DN20	130	58	75	105	4-ø 14	53	SPA52	92	147	SPR63	108	168
DN25	140	68	85	115	4-ø 14	64	SPA52	92	147	SPR75	120	184
DN32	165	78	100	140	4-ø 18	71	SPA63	108	168	SPR83	129	204
DN40	165	88	110	150	4-ø 18	76	SPA75	120	184	SPR92	137	262
DN50	203	102	125	165	4-ø 18	85	SPA83	129	204	SPR105	153	268
DN65	222	122	145	185	8-ø 18	104	SPA92	137	262	SPR125	185	296
DN80	241	138	160	200	8-ø 18	114	SPA125	185	296	SPR140	202	390
DN100	305	158	180	220	8-ø 18	140	SPA140	202	390	SPR160	227	454
DN125	356	188	210	250	8-ø 18	183	SPA160	227	454	SPR190	260	525
DN150	394	212	240	285	8-ø 22	202	SPA190	260	525	SPR210	285	532
DN200	457	268	295	340	12-ø 22	253	SPA210	285	532	SPR240	318	610

Electric Flange Ball Valve

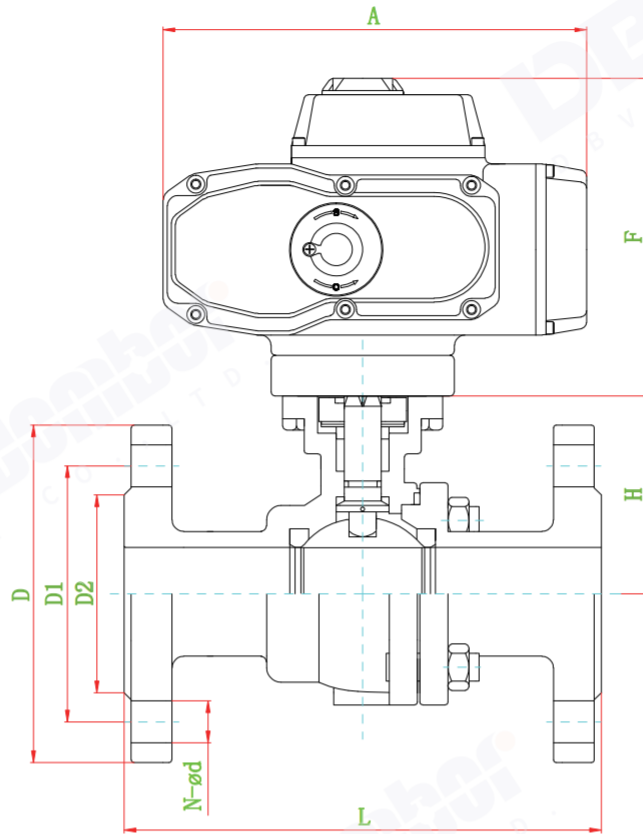

GB PN16 主要外形尺寸表 Main dimensions table

Unit : mm

SIZE	L	D2	D1	D	N-ø d	H	A	F	SIZE
DN15	130	45	65	95	4-ø 14	48	165	138	SP50
DN20	130	58	75	105	4-ø 14	53	165	138	SP50
DN25	140	68	85	115	4-ø 14	64	165	138	SP50
DN32	165	78	100	140	4-ø 18	71	165	138	SP50
DN40	165	88	110	150	4-ø 18	76	212	169	SP100
DN50	203	102	125	165	4-ø 18	85	212	169	SP100
DN65	222	122	145	185	8-ø 18	104	259	203	SP200
DN80	241	138	160	200	8-ø 18	114	259	203	SP400
DN100	305	158	180	220	8-ø 18	140	259	203	SP400
DN125	356	188	210	250	8-ø 18	183	259	203	SP600
DN150	394	212	240	285	8-ø 22	202	284	230	SP1000
DN200	457	268	295	340	12-ø 22	253	284	230	SP1000

**固定球阀
FIXED BALLVALVE**



软密封固定球阀力矩表 Torque table for soft seal fixed ball valve

N.m

SIZE	PN16	PN25	PN40	PN63	PN100	CL150	CL300	CL600	CL900	CL1500	CL2500
DN50	30	40	50	100	180	57	89	180	228	390	589
DN65	50	60	100	200	320	71	144	320	463	688	936
DN80	65	80	150	300	420	95	212	420	612	931	1577
DN100	125	140	250	400	670	192	335	670	946	1524	2665
DN125	250	300	450	650	850	240	519	850	1248	1905	3356
DN150	340	400	585	890	1450	495	744	1450	2184	3134	5501
DN200	485	680	996	1500	2350	832	1250	2350	4016	7215	11786
DN250	810	1140	1690	2560	3950	1105	2036	3950	5910	10990	13222
DN300	1310	1870	2800	4290	6300	1655	3388	6300	10137	16103	20075
DN350	1910	2740	4110	6320	9860	2695	5224	9860	14141	24518	
DN400	2860	4150	6300	9750	14500	3164	7939	14500	19866	29630	
DN450	4500	6500	8900	13500	16900	4793	11970	16900	24400	34392	
DN500	5860	7800	12000	17660	20011	6500	14570	20011	29544	40918	
DN600	8920	13210	20380	31820	42500	10529	25240	42500	59276	85351	
DN700	13320	19380	30670	48020	58000	15770	38069	58000	81410		
DN800	24000	35420	55200	68830	82000	27070	61550	82000	119195		
DN900	34960	52870	82700			42987	95170				
DN1000	43420	66700	102820			56059	129115				

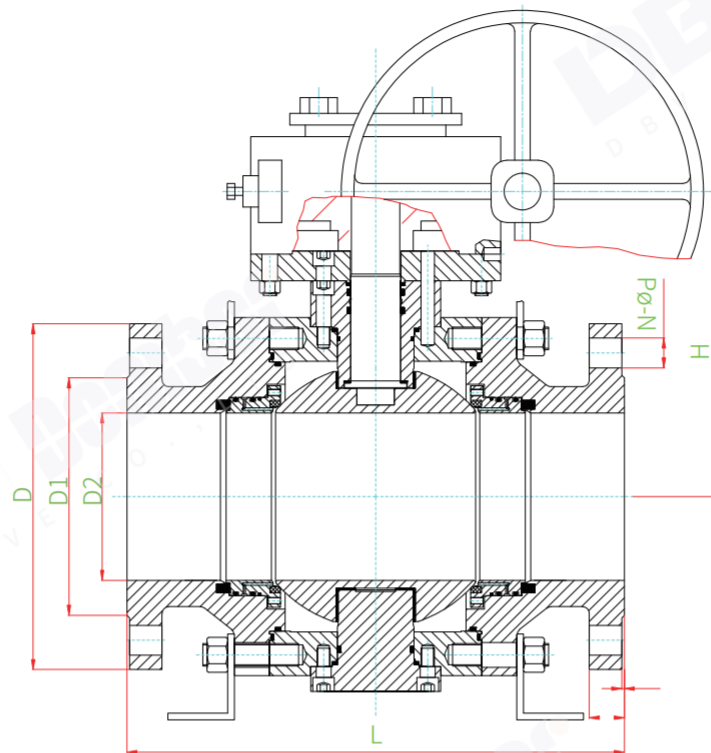

GB PN16 主要外形尺寸表 Main dimensions table

Unit : mm

SIZE	L	D2	D1	D	N-ø d	H	T	F
DN50	203	102	125	165	4-ø 18	107	21	3
DN65	222	122	145	185	8-ø 18	125	21	3
DN80	241	138	160	200	8-ø 18	152	23	3
DN100	305	158	180	220	8-ø 18	180	23	3
DN125	356	188	210	250	8-ø 18	260	25	3
DN150	394	212	240	285	8-ø 22	380	25	3
DN200	457	268	295	340	12-ø 22	420	27	3
DN250	533	320	355	405	12-ø 26	480	29	3
DN300	610	378	410	460	12-ø 26	550	32	4
DN350	685	438	470	520	16-ø 26	580	34	4
DN400	762	490	525	580	16-ø 30	690	36	4
DN450	864	550	585	640	20-ø 30	730	44	4
DN500	914	610	650	715	20-ø 33	770	48	4
DN600	1067	725	770	840	20-ø 36	990	59	5
DN700	1245	795	840	910	24-ø 36	1100	63	5
DN800	1372	900	950	1025	24-ø 39	1250	67	5
DN900	1524	1000	1050	1125	28-ø 39	1400	69	5
DN1000	1753	1115	1170	1255	28-ø 42	1500	73	5

Three Piece Ball Valve



气动对焊球阀



气动螺纹球阀



气动卡箍球阀

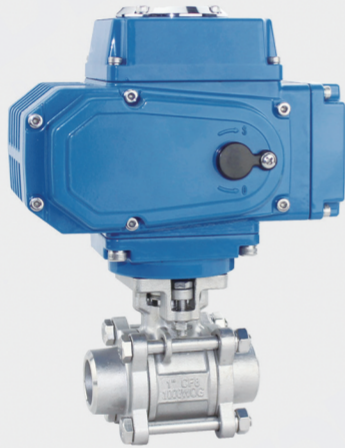

电动对焊球阀

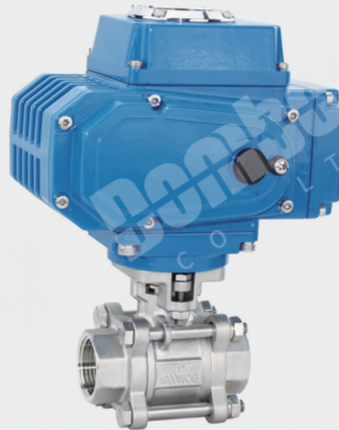

电动螺纹球阀



电动卡箍球阀

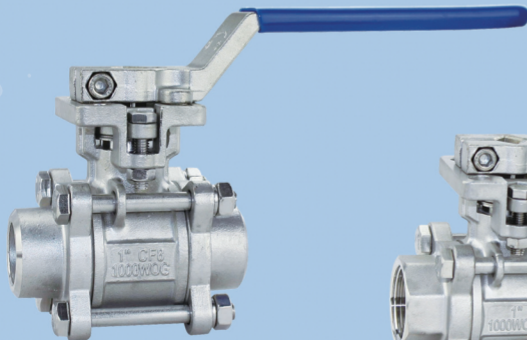

手动对焊球阀

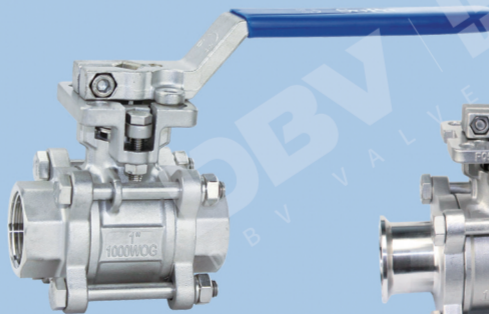

手动螺纹球阀



手动卡箍球阀

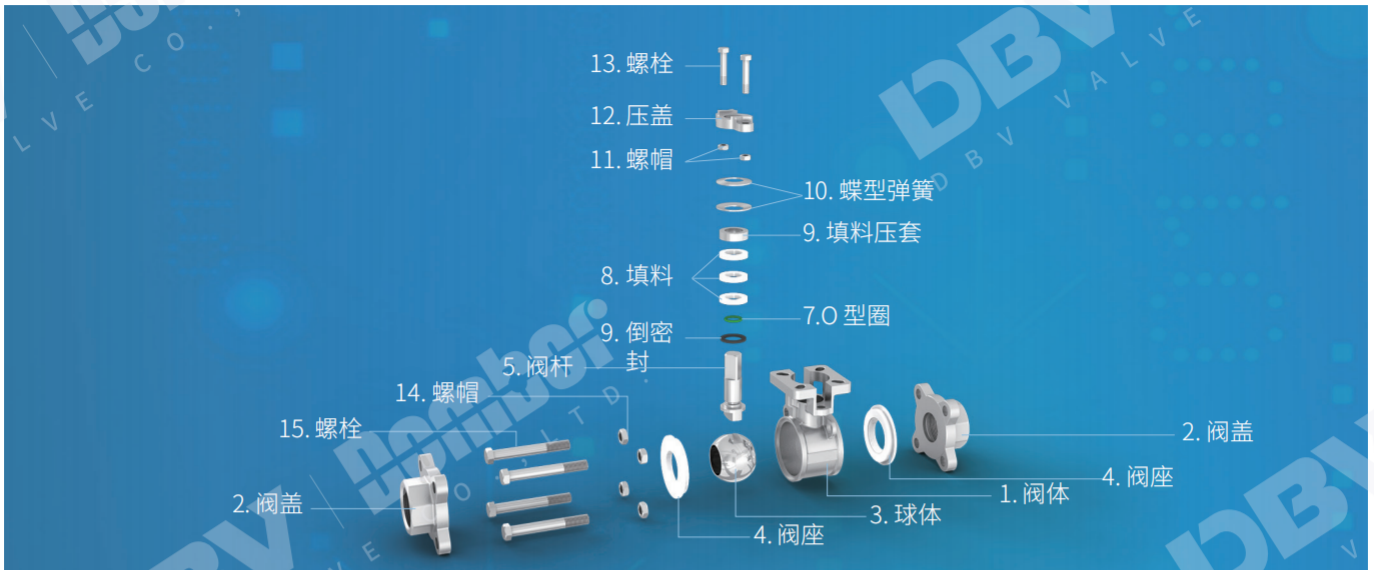

主要零件材料 Main parts materials

序号 Serial number	零件名称 Part Name	材料 material
1	阀体 Body	CF8、CF8M、CF3M
2	阀盖 Bonnet	CF8、CF8M、CF3M
3	球体 Ball body	SS304、SS316、SS316L
4	阀座 Seat	PTFE、PPL
5	阀杆 Stem	SS304、SS316、SS316L
6	倒密封 Inverted seal	PTFE、PPL
7	O型圈 O-ring	氟橡胶 (fluororubber)
8	填料 Filler	PTFE、PPL
9	填料压套 Filling clamping ring	SS304
10	蝶形弹簧 Butterfly spring	SS304
11	螺帽 NUT	SS304
12	压盖 Gland of valve	CF8
13	螺栓 Screw	SS304
14	螺帽 NUT	SS304
15	螺栓 Screw	SS304

产品技术参数 Product Specifications

公称压力 Nominal pressure	1000WOG
公称通径 Nominal diameter	DN15~DN100
连接方式 Connection method	BSPT、BSP、NPT、DIN、JIS、RC、G、对焊 (Butt welding)、 承插焊 (Socket welding)
阀体材料 Body material	CF8、CF8M、CF3M 等
阀座形式 Valve seat form	PTFE、PPL
适用温度 proper temperature	软阀座：-20~ + 200C° (Soft seat: -20~ + 200C°)
泄漏等级 Leakage level	ANSI VI
检测标准 Testing standards	GB/T13927、API598
操作方式 Operation method	手动、气动、电动等 Manual, pneumatic, electric, etc.
可选项 Optional	防静电设计、禁油处理、禁铜处理、球面特殊处理 Anti-static design、oil-free treatment、copper-free treatment、 spherical special treatment

Three Piece Ball Valve

产品结构特点

Product structure design features

阀杆防吹出结构设计（见图 1）

阀杆防吹出结构设计，下端大上端小的阀杆在上端盖和螺丝的定位下，即使在阀腔异常的情况下，也能保证阀杆不会被介质吹出。

Valve stem anti-blowing structure design (see picture 1)

Valve stem anti-blowing structure design, the lower end is larger and the upper end is smaller. Under the positioning of the upper end cover and screws, even in the case of abnormal valve cavity, it can also ensure that the valve stem will not be blown out by the medium.



图 1 (picture 1)

防静电设计（见图 2）

固定球阀通过防静电设计使球体、阀杆、阀体形成静电通道。从而将球体与阀座开关过程中由于摩擦产生的静电通过阀体引到大地，防止静电火花可能引起的火灾或爆炸危险。

Anti-static design (See picture 2)

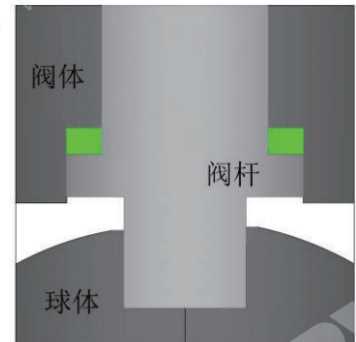
The fixed ball valve adopts anti-static design to make the ball, stem and valve body form an electrostatic channel. So that the ball and the seat are switched during the process, static electricity generated by friction is led to the ground through the valve body. Prevent the risk of fire or explosion caused by static sparks.



图 2 (picture 2)

KV 值 rated

SIZE	DN15	DN20	DN25	DN32	DN40	DN50	DN65	DN80	DN100
Kv	21	38	72	112	170	275	380	512	941

软密封力矩表 Soft seal torque table

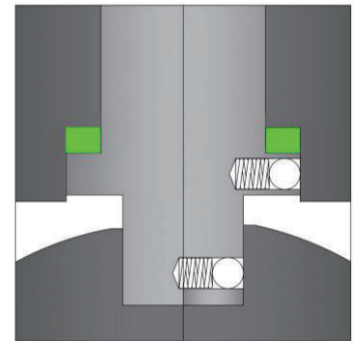
N.m

SIZE	DN15	DN20	DN25	DN32	DN40	DN50	DN65	DN80	DN100
PN16	3	4	10	13	16	25	50	65	125
PN25	5	7	11	15	18	30	60	80	140
PN40	7	10	24	30	35	50	100	150	250
PN63	15	30	50	65	80	100	200	300	400

Three Piece Ball Valve

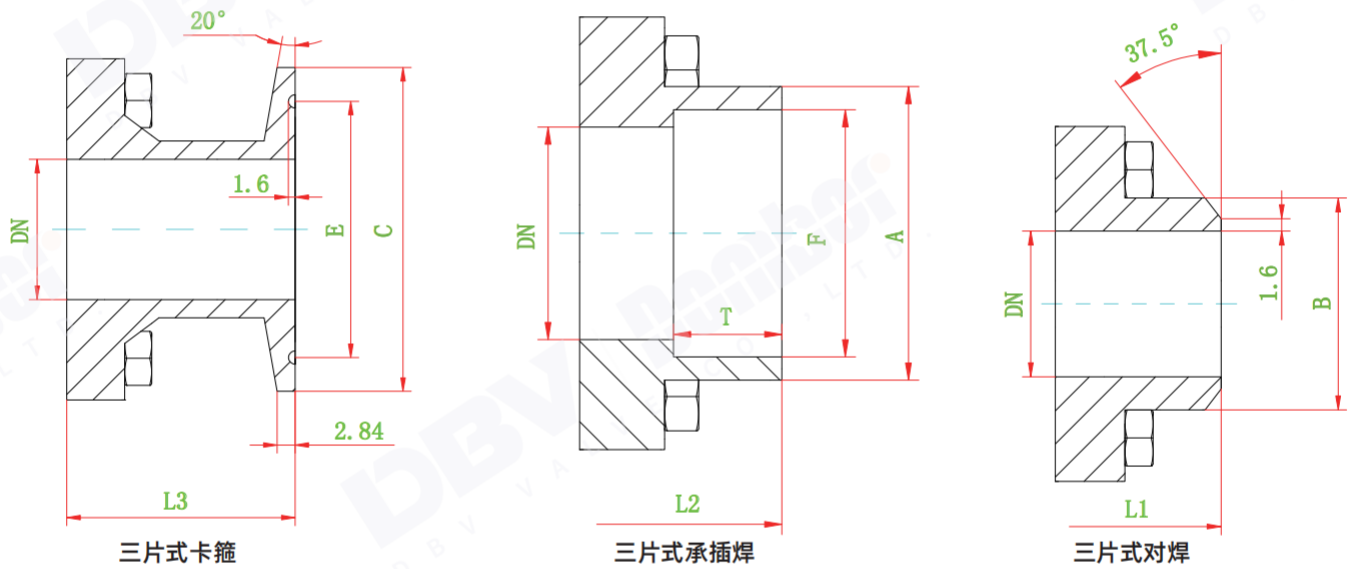
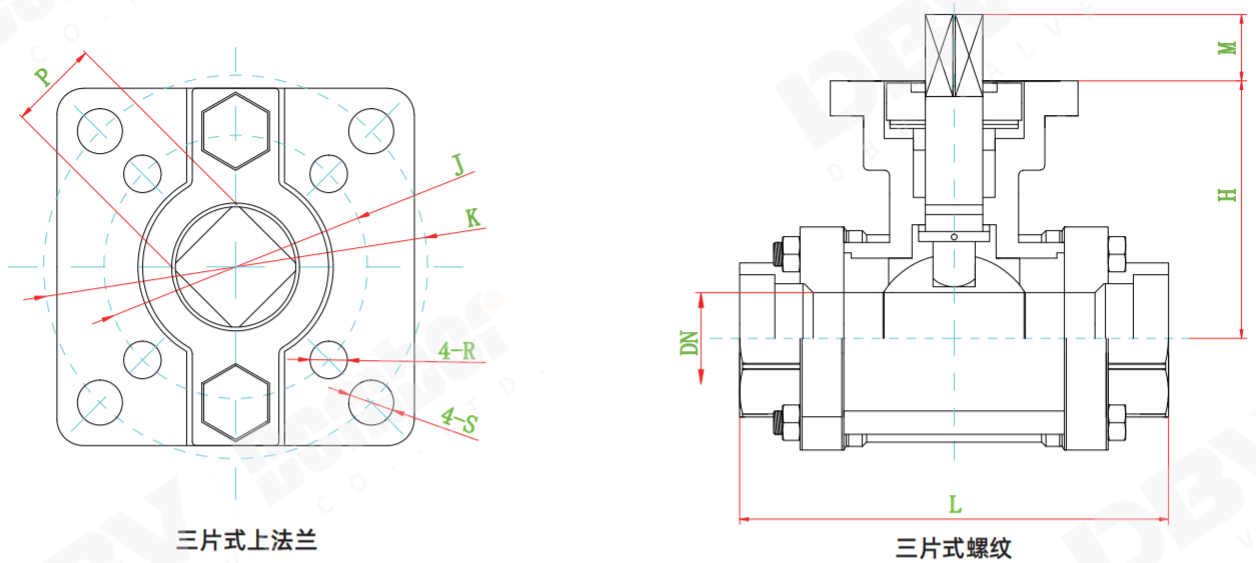

1000WOG 主要外形尺寸表 Main dimensions table

Unit : mm

SIZE	L	L1	L2	L3	A	C	B	E	F	T	H	M	P	J	K	R	S	
DN15	1/2"	73	75	65	96	22.4	50.4	22.5	43.6	22.5	10	49	10	9	42	50	6	7
DN20	3/4"	83	90	76	108	27.8	50.4	27	43.6	28.5	13	54	10	9	42	50	6	7
DN25	1"	90	100	86	111	34.7	50.4	34.5	43.6	34.5	13	59	13	11	42	50	6	7
DN32	1-1/4"	108	110	98	129	43.3	50.4	43	43.6	43	13	71	13	11	42	50	6	7
DN40	1-1/2"	119	125	114	141	49.3	50.4	49	43.6	49	13	76	16	14	50	70	7	9
DN50	2"	140	150	132	158	61.4	63.9	62	56.3	61	16	84	16	14	50	70	7	9
DN65	3/8"	164	190	164	173	75	77.4	76.5	70.6	76	16	107	19	17	70	102	9	11
DN80	1/2"	192	220	182	201	90	90.9	92	83.3	92	16	118	19	17	70	102	9	11
DN100	3/4"	202	270	235	283	115.6	118.9	115	110.3	115	19	138	19	17	70	102	9	11

Pneumatic/electric Three Piece Threaded Ball Valve

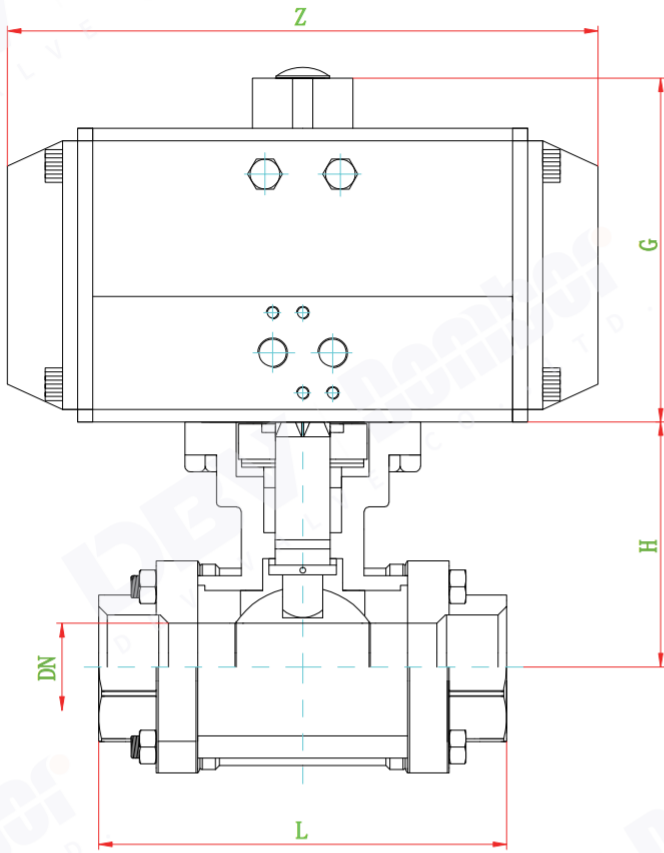

气动螺纹球阀

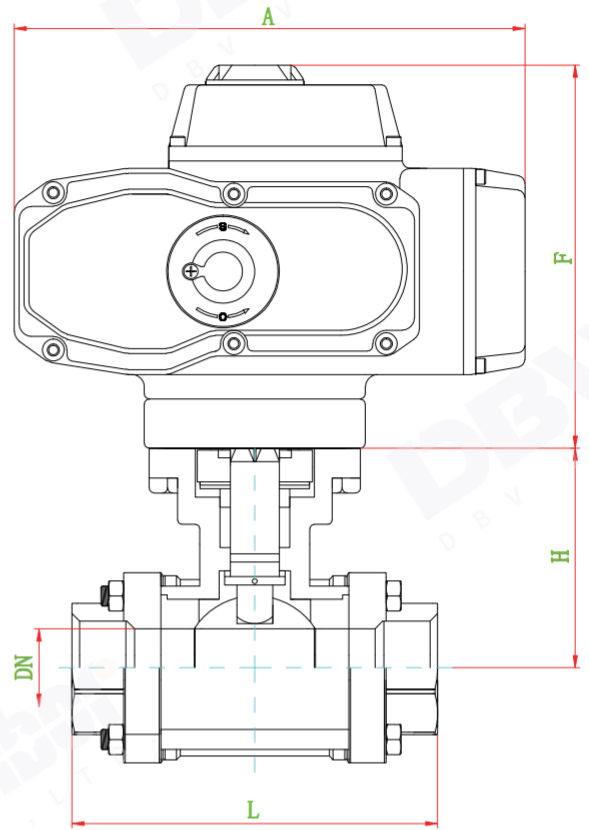

电动螺纹球阀

1000WOG 主要外形尺寸表 Main dimensions table

Unit : mm

SIZE		L	H	双作用 (DA)			单作用 (SR)			A	F	SIZE
				SIZE	G	Z	SIZE	G	Z			
DN15	1/2"	73	49	SPA52	92	147	SPR52	92	147	165	138	SP50
DN20	3/4"	83	54	SPA52	92	147	SPR63	108	168	165	138	SP50
DN25	1"	90	59	SPA52	92	147	SPR75	120	184	165	138	SP50
DN32	1-1/4"	108	71	SPA63	108	168	SPR83	129	204	165	138	SP50
DN40	1-1/2"	119	76	SPA75	120	184	SPR92	137	262	212	169	SP100
DN50	2"	140	84	SPA83	129	204	SPR105	153	268	212	169	SP100
DN65	3/8"	164	100	SPA92	137	262	SPR125	185	296	259	203	SP200
DN80	1/2"	192	116	SPA105	153	296	SPR140	202	390	259	203	SP200
DN100	3/4"	202	140	SPA125	185	390	SPR160	227	454	259	203	SP400

Pneumatic/electric Three Piece Butt Welding Ball Valve

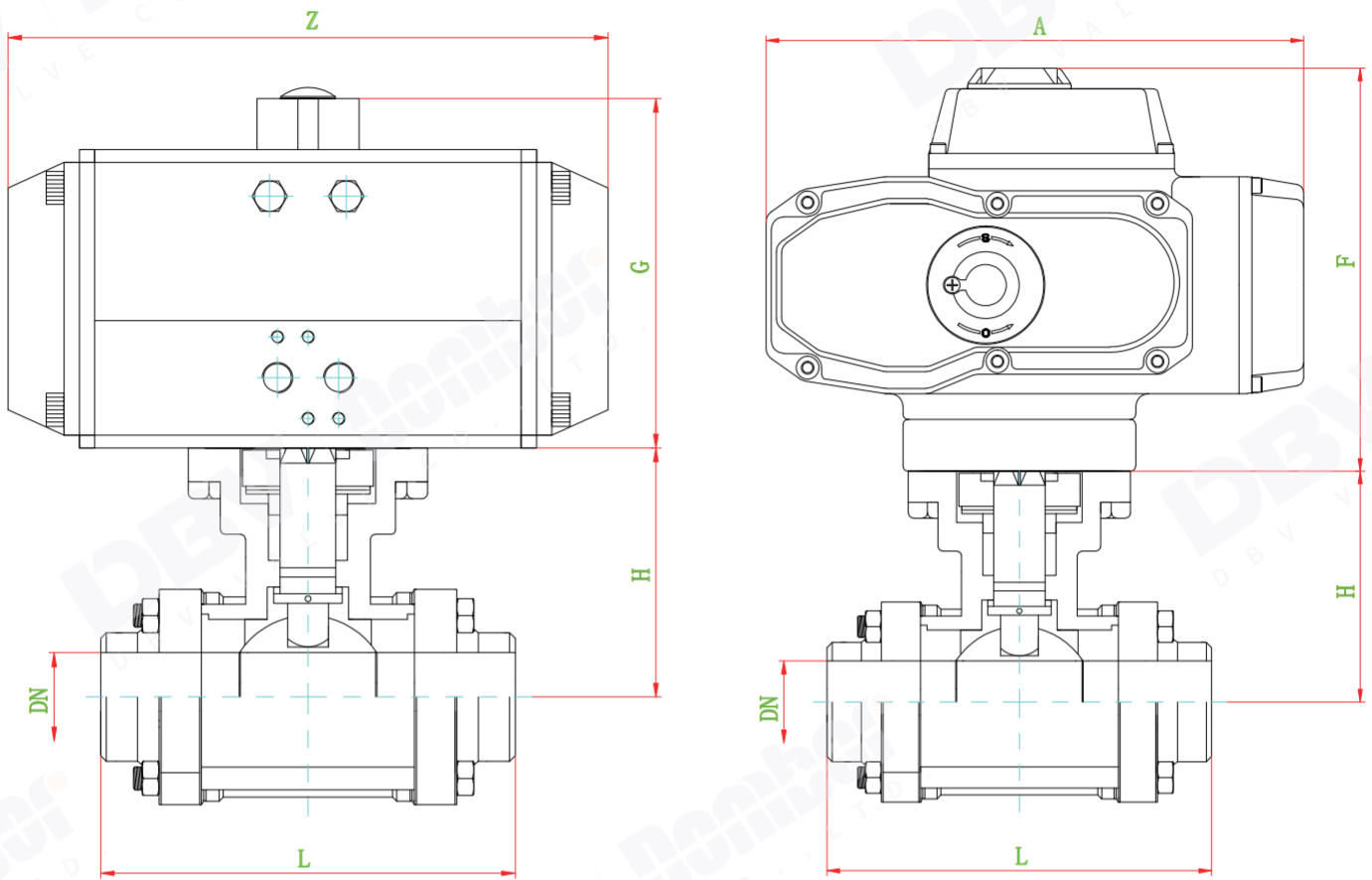

气动对焊球阀

电动对焊球阀

1000WOG 主要外形尺寸表 Main dimensions table

Unit : mm

SIZE		L	H	双作用 (DA)			单作用 (SR)			A	F	SIZE
				SIZE	G	Z	SIZE	G	Z			
DN15	1/2"	75	49	SPA52	92	147	SPR52	92	147	165	138	SP50
DN20	3/4"	90	54	SPA52	92	147	SPR63	108	168	165	138	SP50
DN25	1"	100	59	SPA52	92	147	SPR75	120	184	165	138	SP50
DN32	1-1/4"	110	71	SPA63	108	168	SPR83	129	204	165	138	SP50
DN40	1-1/2"	125	76	SPA75	120	184	SPR92	137	262	212	169	SP100
DN50	2"	150	84	SPA83	129	204	SPR105	153	268	212	169	SP100
DN65	3/8"	190	100	SPA92	137	262	SPR125	185	296	259	203	SP200
DN80	1/2"	220	116	SPA105	153	296	SPR140	202	390	259	203	SP200
DN100	3/4"	270	140	SPA125	185	390	SPR160	227	454	259	203	SP400

Pneumatic/electric Three Piece Socket Welding Ball Valve

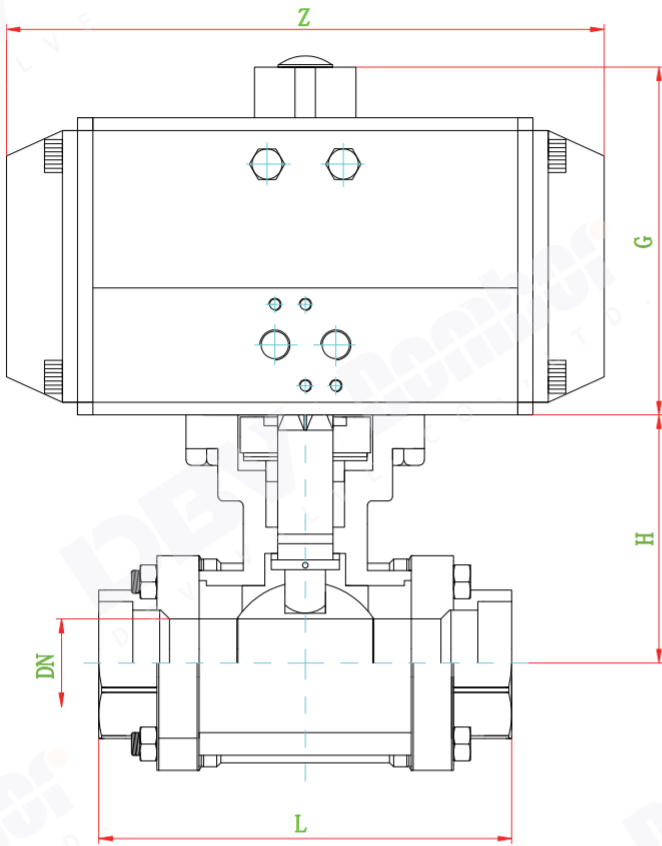

气动承插焊球阀

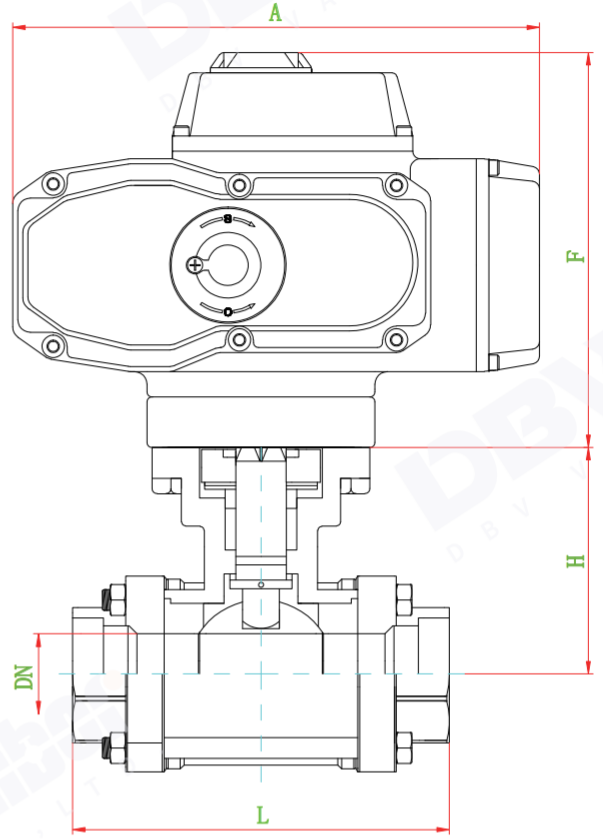

电动承插焊球阀

1000WOG 主要外形尺寸表 Main dimensions table

Unit : mm

SIZE		L	H	双作用 (DA)			单作用 (SR)			A	F	SIZE
				SIZE	G	Z	SIZE	G	Z			
DN15	1/2"	65	49	SPA52	92	147	SPR52	92	147	165	138	SP50
DN20	3/4"	76	54	SPA52	92	147	SPR63	108	168	165	138	SP50
DN25	1"	86	59	SPA52	92	147	SPR75	120	184	165	138	SP50
DN32	1-1/4"	98	71	SPA63	108	168	SPR83	129	204	165	138	SP50
DN40	1-1/2"	114	76	SPA75	120	184	SPR92	137	262	212	169	SP100
DN50	2"	132	84	SPA83	129	204	SPR105	153	268	212	169	SP100
DN65	3/8"	164	100	SPA92	137	262	SPR125	185	296	259	203	SP200
DN80	1/2"	182	116	SPA105	153	296	SPR140	202	390	259	203	SP200
DN100	3/4"	235	140	SPA125	185	390	SPR160	227	454	259	203	SP400

Pneumatic/electric Three Piece Clamp Ball Valve

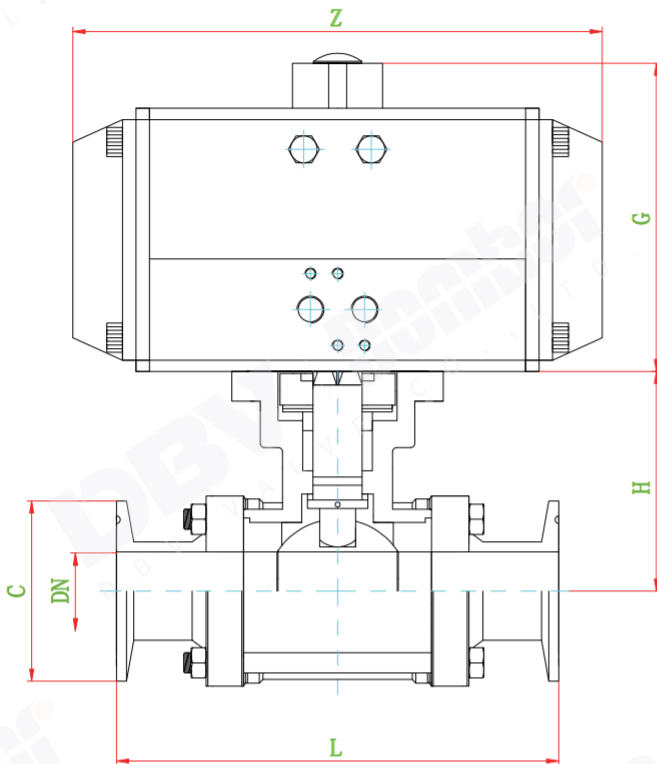

气动卡箍球阀

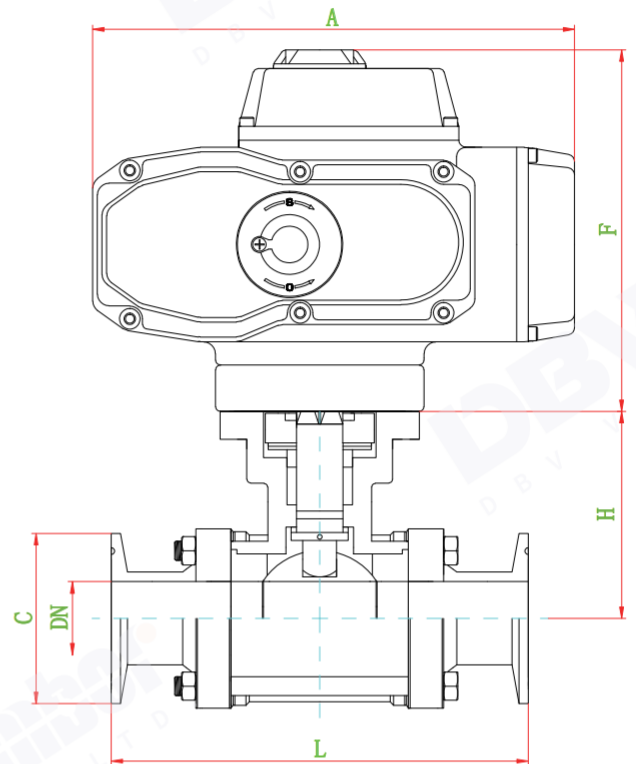

电动卡箍球阀

1000WOG 主要外形尺寸表 Main dimensions table

Unit : mm

SIZE	L	C	H	双作用 (DA)			单作用 (SR)			A	F	SIZE	
				SIZE	G	Z	SIZE	G	Z				
DN15	1/2"	96	50.4	49	SPA52	92	147	SPR52	92	147	165	138	SP50
DN20	3/4"	108	50.4	54	SPA52	92	147	SPR63	108	168	165	138	SP50
DN25	1"	111	50.4	59	SPA52	92	147	SPR75	120	184	165	138	SP50
DN32	1-1/4"	129	50.4	71	SPA63	108	168	SPR83	129	204	165	138	SP50
DN40	1-1/2"	141	50.4	76	SPA75	120	184	SPR92	137	262	212	169	SP100
DN50	2"	158	63.9	84	SPA83	129	204	SPR105	153	268	212	169	SP100
DN65	3/8"	173	77.4	100	SPA92	137	262	SPR125	185	296	259	203	SP200
DN80	1/2"	201	90.9	116	SPA105	153	296	SPR140	202	390	259	203	SP200
DN100	3/4"	283	118.9	140	SPA125	185	390	SPR160	227	454	259	203	SP400

Thin Ball Valve

YHIN BALL VALVE

薄型球阀



电动薄型球阀

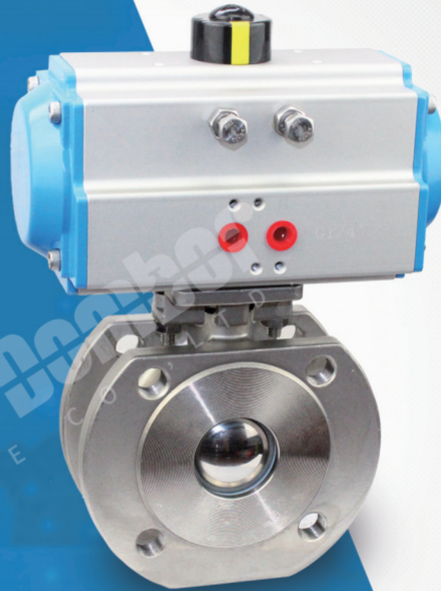

气动薄型球阀



手动薄型球阀

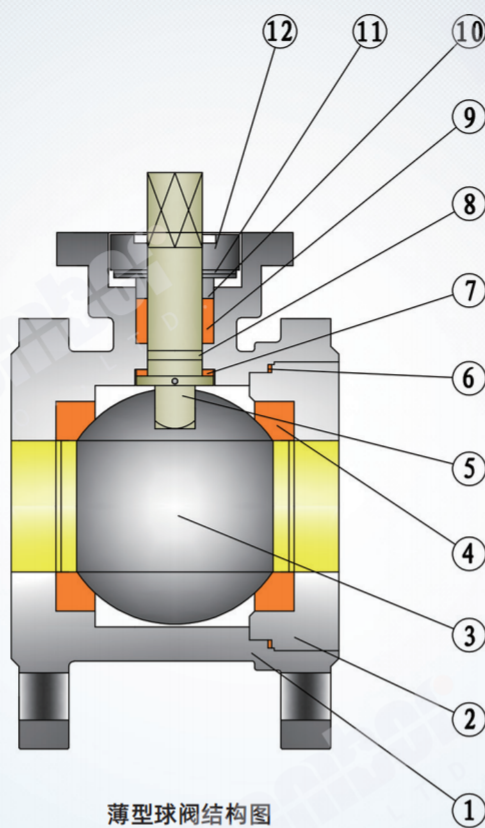

薄型球阀结构图

主要零件及材料 Main parts and materials

NO.	零件名称 Part Name	材料 material
1	阀体 Body	WCB、CF8、CF8M、CF3M 等
2	阀盖 Bonnet	WCB、CF8、CF8M、CF3M 等
3	球体 Ball body	SS304、SS316、SS316L、SS316L + STL 等
4	阀座 Seat	PTFE、PPL、金属密封等
5	阀杆 Stem	304、SS316、316L、17-4PH、S20910
6	中头垫片 Middle head gasket	PTFE、PPL、金属垫片
7	倒密封 Inverted seal	PTFE、PPL、不锈钢缠绕石墨
8	O 型圈 O-ring	氟橡胶
9	填料 Filler	PTFE、PPL、柔性石墨
10	填料压环 Filling clamping ring	SS304
11	蝶形弹簧 Butterfly spring	SS304
12	压盖 Gland of valve	CF8

Pneumatic/electric Thin Ball Valve

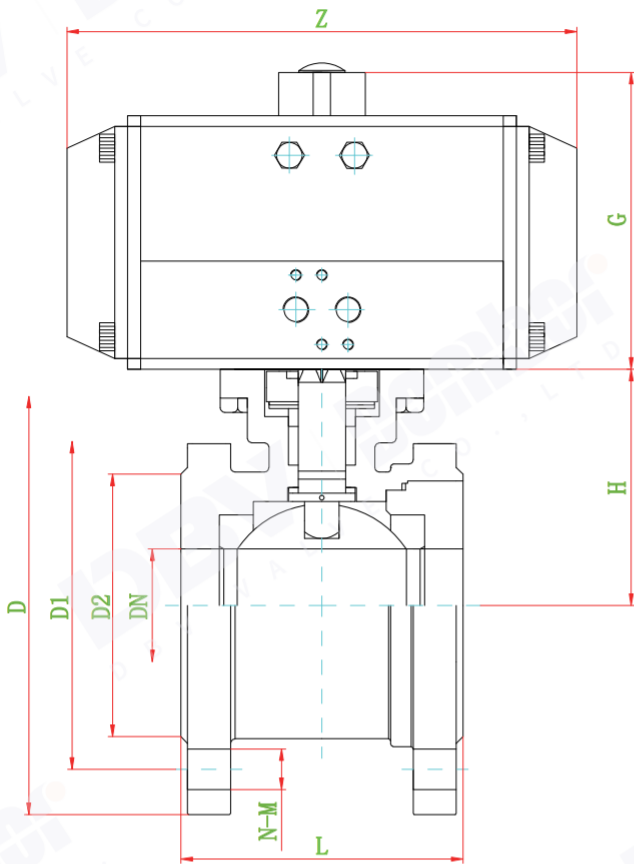

气动薄型球阀

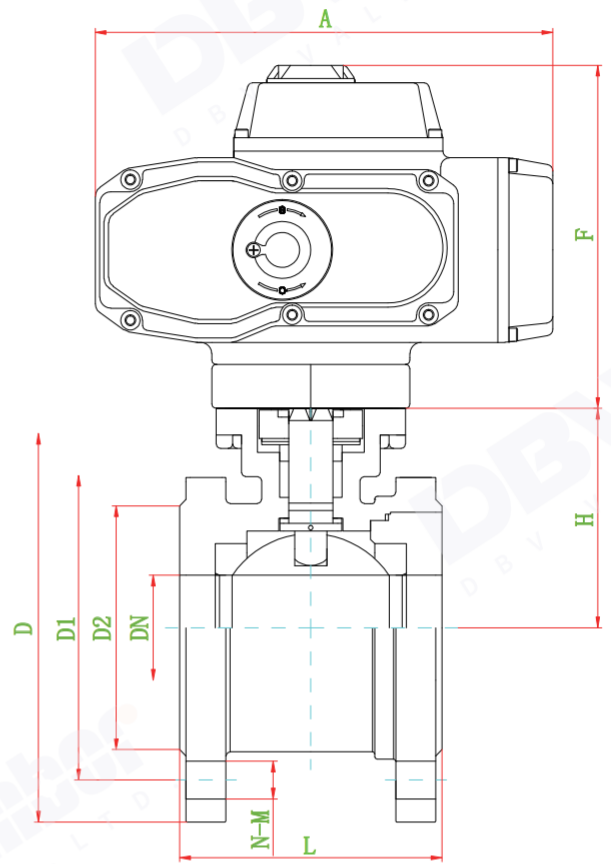

电动薄型球阀

GB PN16 主要外形尺寸表 Main dimensions table

Unit : mm

SIZE	L	D2	D1	D	N-M	H	双作用 (DA)			单作用 (SR)			A	F	SIZE
							SIZE	G	Z	SIZE	G	Z			
DN15	42	45	65	95	4-12	46	SPA52	92	147	SPR52	92	147	165	138	SP50
DN20	44	55	75	105	4-12	51	SPA52	92	147	SPR63	108	168	165	138	SP50
DN25	50	65	85	115	4-12	62	SPA52	92	147	SPR75	120	184	165	138	SP50
DN32	60	78	100	135	4-16	72	SPA63	108	168	SPR83	129	204	165	138	SP50
DN40	65	85	110	145	4-16	78	SPA75	120	184	SPR92	137	262	212	169	SP100
DN50	80	100	125	160	4-16	86	SPA83	129	204	SPR105	153	268	212	169	SP100
DN65	110	120	145	180	4-16	108	SPA92	137	262	SPR125	185	296	259	203	SP200
DN80	120	135	160	195	8-16	116	SPA125	185	296	SPR140	202	390	259	203	SP400
DN100	150	155	180	215	8-16	139	SPA140	202	390	SPR160	227	454	259	203	SP400
DN125	180	185	210	245	8-16	176	SPA160	227	454	SPR190	260	525	259	203	SP600
DN150	225	210	240	280	8-20	192	SPA190	260	525	SPR210	285	532	284	230	SP1000
DN200	275	265	295	340	12-20	280	SPA210	285	532	SPR240	318	610	284	230	SP1000

Pneumatic/electric Thin Ball Valve

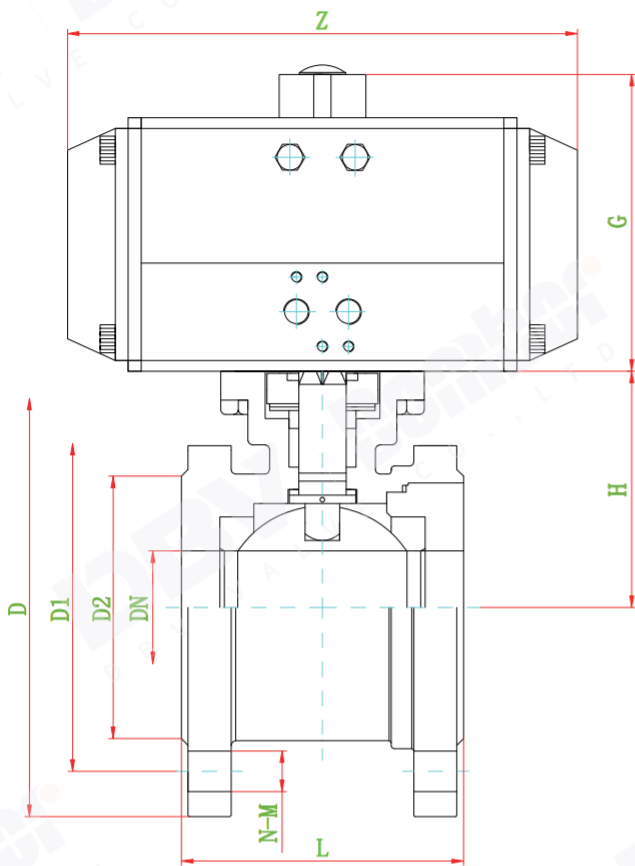

气动薄型球阀

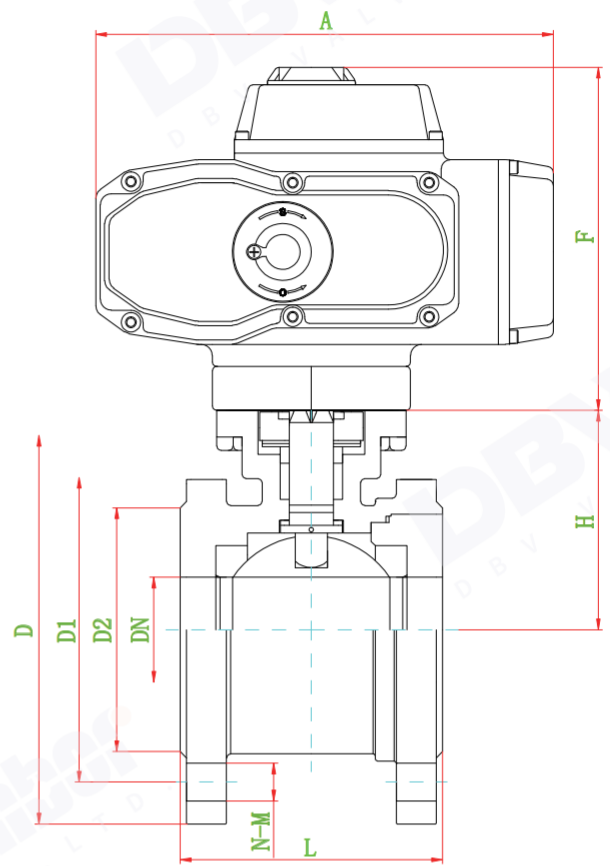

电动薄型球阀

ASME CLASS150 主要外形尺寸表 Main dimensions table

Unit : mm

SIZE	L	D2	D1	D	N-M	H	双作用 (DA)			单作用 (SR)			A	F	SIZE
							SIZE	G	Z	SIZE	G	Z			
DN15	42	35	60.5	89	4-14	46	SPA52	92	147	SPR52	92	147	165	138	SP50
DN20	44	43	70	98	4-14	51	SPA52	92	147	SPR63	108	168	165	138	SP50
DN25	50	51	79.2	108	4-14	62	SPA52	92	147	SPR75	120	184	165	138	SP50
DN32	60	64	88.9	117	4-14	72	SPA63	108	168	SPR83	129	204	165	138	SP50
DN40	65	73	98.6	127	4-14	78	SPA75	120	184	SPR92	137	262	212	169	SP100
DN50	80	92	120.7	152	4-16	86	SPA83	129	204	SPR105	153	268	212	169	SP100
DN65	110	105	139.7	178	4-16	108	SPA92	137	262	SPR125	185	296	259	203	SP200
DN80	120	127	152.4	190	4-16	116	SPA125	185	296	SPR140	202	390	259	203	SP400
DN100	150	157	190.5	229	8-16	139	SPA140	202	390	SPR160	227	454	259	203	SP400
DN125	180	186	216	254	8-20	176	SPA160	227	454	SPR190	260	525	259	203	SP600
DN150	225	216	241.3	279	8-20	192	SPA190	260	525	SPR210	285	532	284	230	SP1000
DN200	275	269.9	298.5	345	8-20	280	SPA210	285	532	SPR240	318	610	284	230	SP1000

Comparison Table Of Common Valve Materials

阀体材质的使用温度 - 压力范围

Working temperature and pressure range of valve body material

温度 empC°	LCB				WCB				CF8				CF8M			
	PN16	PN25	PN40	PN64	PN16	PN25	PN40	PN64	PN16	PN25	PN40	PN64	PN16	PN25	PN40	PN64
-29~38	1.5	2.4	3.9	6.1	1.6	5	4.0	6.4	1.5	2.4	4.0	6.3	1.5	2.4	3.9	6.3
93	1.4	2.2	3.8	5.7	1.4	2.3	3.7	5.9	1.4	2.1	3.3	5.2	1.3	2.0	3.4	5.4
149	1.3	2.1	3.7	5.6	1.3	2.1	3.6	5.7	1.3	1.9	3.0	4.7	1.2	1.9	3.1	4.9
204	1.1	1.9	3.5	5.4	1.1	1.9	3.4	5.6	1.1	1.7	2.8	4.3	1.1	1.7	2.8	4.5
260	1.0	1.7	3.3	5.1	1.0	1.7	3.2	5.2	1.0	1.5	2.6	4.0	1.0	1.6	2.6	4.1
315	0.8	1.4	3.0	4.7	0.8	1.4	2.8	4.8	0.8	1.3	2.3	3.7	0.8	1.3	2.4	3.9
343	0.7	1.3	2.9	4.6	0.7	1.3	2.7	4.7	0.7	1.2	2.3	3.7	0.7	1.2	2.3	3.8
371	0.6	1.2	2.8	4.5	0.6	1.2	2.7	4.7	0.6	1.1	2.2	3.7	0.6	1.1	2.2	3.7
399	0.5	1.1	2.5	4.2	0.5	1.1	2.6	4.4	0.5	1.0	2.1	3.6	0.5	1.0	2.2	3.7
427	0.5	0.9	2.1	3.3	0.5	1.0	2.1	3.6	0.5	0.9	2.0	3.5	0.5	0.9	2.1	3.6
454	0.4	0.7	1.5	2.3	0.4	0.7	1.4	2.3	0.4	0.8	2.0	3.4	0.4	0.8	2.0	3.6
482					0.3	0.5	0.9	1.5	0.3	0.7	1.9	3.3	0.3	0.7	1.9	3.6
510					0.2	0.3	0.5	0.9	0.2	0.6	1.8	3.2	0.2	0.6	1.8	3.3
538					0.1	0.1	0.3	0.4	0.1	0.4	1.5	2.8	0.1	0.4	1.6	3.0

ISO5122 连接标准的最大转矩

Maximum torque of ISO5122 connection standard

法兰代号	F03	F04	F05	F07	F10	F12	F14	F16	F25	F30	F35	F40	F48	F60
转矩 /N.m	32	63	125	250	500	1000	2000	4000	8000	16000	32000	63000	125000	250000
圆轴尺寸 mm	12	14	18	22	28	36	48	60	72	98	160	180	220	280
键销长度 mm	25	27	27	30	42	52	60	75	105	125	175	192	242	302
方轴尺寸 mm	9	11	14	17	22	27	36	46	55	75				

注：表中扭矩规定值是在螺栓拉伸应力只有“290Mpa”且法兰接合面之间的摩擦系数为“0.2”的基础上确定的，不同的参数会得出不同的传输转矩值。

Note: The specified torque value in the table is determined on the basis that the tensile stress of the bolt is only 290Mpa and the friction coefficient between the flange joint surfaces is 0.2. Different parameters will result in different transmission torque values.

Comparison Table Of Common Valve Materials

阀门常用材料牌号对照表

Comparison table of common valve materials

材料名称 Material name	美国 (ASTM) ASTM	日本 (JIS) JIS	德国 (DIN) DIN	中国 (GB) GB	主要化学成分 Major chemical composition
碳素钢 (铸) Carbon Steel(cast)	WCA、WCB、WCC	SCPH2	1.0501	WCA、WCB、WCC	C: ≤ 0.30
铬钼钢 (铸) Cr-Mo Steel(cast)	WC6 WC9	SCPH21 SCPH32	1.7335	15CrMo 15Cr2Mov	C: ≤ 0.20 C: ≤ 0.18
不锈钢 (铸) Stainless Steel(cast)	CF8	SCS13 SCS13A	1.4308	CF8(GB12230)	C: ≤ 0.08 Cr: 18.0-21.0
	CF8M	SCS14 SCS14A	1.4580 1.4581	CF8M(GB12230)	C: ≤ 0.08 Cr: 18.0-21.0 Mo:2.0-3.0
	CF3	--	1.4306	CF3 (GB12230)	C: ≤ 0.03 C: ≤ 17.2-21.0
	CF3M	--	1.4435	CF3M (GB12230)	C: ≤ 0.03 Cr: 7.0-21.0
不锈钢 (棒) Stainless Steel(rod)	304	SUS304	1.4301	0Cr18Ni9	C: ≤ 0.08 Cr: 7.0-20.0
	316	SUS316	1.4401 1.4436	0Cr17Ni12Mo2	C: ≤ 0.08 Cr: 16.0-18.0 Mo:2.0-3.0
	304L	SUS304L	1.4036	00Cr19Ni10	C: ≤ 0.03 Cr: 18.0-20.0
	316L	SUS316L	1.4435 1.4404	00Cr17Ni14Mo2	C: ≤ 0.03 Cr: 2.0-3.0
	410	SUS410	1.4006	1Cr13	C: ≤ 0.15 Cr: 11.5-13.0
	416	SUS416	1.4005	Y1Cr13	C: ≤ 0.15 Cr: 12.0-14.0
	420	SUS420	1.4021	2Cr13	C:0.16-0.25 C:16.0-18.0
	440B	SUS440B	1.4112	9Cr18Mov	C:0.75-0.95 C:16.0-18.0
	440C	SUS440C	1.4125	9Cr18	C:0.75-0.95 C:16.0-18.0
630	SUS630 SUS24 (铸 cast)	1.4542	0Cr17Ni4Cu4Nb (17-4PH)	Cr:16.5 Ni:4.0 Cu:3.5	

Valve Material Selection Table

阀门材料选用表

Valve material selection table

流体 Fluid	材料 Material													
	碳钢 Carbon steel	铸铁 Cast iro	302 或 304 不锈钢 302or 304S	316 不锈钢 316SS	青铜 Bronze	蒙乃尔 合金 Monel	哈氏 合金 B Haste lloy B	哈氏 合金 C Haste lloy C	不锈 钢 #20 SS#20	钛 Titanium	钴铬 合金 #6 Co-Cr alloy#6	416 不锈钢 416SS	440C 不锈钢 440CSS	17-4PH 不锈钢 17- 4PHSS
醋酸 (无气的)	A	A	A	A	A	A	I.L	A	A	I.L	I.L	A	A	A
醋酸 (充气的)	C	C	B	B	B	B	A	A	A	A	A	C	C	B
醋酸蒸汽	C	C	A	A	A	A	A	A	A	A	A	C	C	B
乙醛	C	C	A	A	B	B	I.L	A	A	A	A	C	C	B
丙酮	A	A	A	A	A	A	A	A	A	A	A	A	A	A
乙炔	A	A	A	A	I.L	A	A	A	A	I.L	A	A	A	A
乙醛	A	A	A	A	A	A	A	A	A	A	A	A	A	A
硫酸铝	C	C	A	A	A	A	A	A	A	A	I.L	C	C	I.L
氨	A	A	A	A	A	A	A	A	A	A	A	A	A	I.L
氯化铵	C	C	B	B	A	A	A	A	A	A	A	C	C	I.L
硝酸铵	A	A	A	A	C	C	A	A	A	A	A	C	C	I.L
磷酸铵 (一价的)	C	C	A	A	B	B	A	A	A	A	A	B	B	I.L
硫酸铵	C	C	B	A	B	B	A	A	A	A	A	C	C	I.L
亚硫酸铵	C	C	A	A	C	C	I.L	A	A	A	A	C	C	I.L
苯胺	A	A	A	A	A	A	A	A	A	A	A	C	C	I.L
沥青	A	A	A	A	C	C	A	A	A	I.L	A	A	A	A
啤酒	B	B	A	A	B	B	A	A	A	A	A	B	B	A
茶	A	A	A	A	A	A	B	A	A	A	A	A	A	A
苯甲酸	C	C	A	A	A	A	I.L	A	A	A	I.L	A	A	A
硼酸	C	C	A	A	A	A	B	A	A	A	A	B	B	I.L
丁烷	A	A	A	A	A	A	A	A	A	I.L	A	A	A	A
氧化钙	B	B	C	B	C	A	A	A	A	A	I.L	C	C	I.L
次氯化钙	C	C	B	B	B	B	C	A	A	A	I.L	C	C	I.L
石碳酸	B	B	A	A	A	A	A	A	A	A	A	I.L	I.L	I.L
二氧化碳 (干的)	A	A	A	A	A	A	A	A	A	A	A	A	A	A
二氧化碳 (湿的)	C	C	A	A	A	A	A	A	A	A	A	A	A	I.L
二硫化碳	A	A	A	A	C	B	A	A	A	A	A	B	B	A
碳化	B	B	B	B	A	A	B	A	A	A	I.L	C	C	C
碳酸	C	C	B	B	A	A	A	A	A	I.L	I.L	A	A	I.L
氮气体 (干的)	A	A	B	B	B	A	A	A	A	C	B	C	C	A
氮气体 (湿的)	C	C	C	C	C	C	C	B	C	A	B	C	C	C
液	C	C	C	C	B	C	A	A	B	C	B	C	C	C
铬酸	C	C	C	C	C	A	C	A	C	A	B	C	C	C
柠檬酸	I.L	C	B	B	A	B	A	A	A	A	I.L	B	B	B
焦炉气	A	A	A	A	B	B	A	A	A	A	A	A	A	A
硫酸铜	C	C	B	B	B	C	I.L	A	A	A	I.A	A	A	A
棉子油	A	A	A	A	A	A	A	A	A	A	A	A	A	A
杂酚油	A	A	A	A	A	A	A	A	A	I.L	A	A	A	A
乙烷	A	A	A	A	A	A	A	A	A	A	A	A	A	A
乙醚	B	B	A	A	B	A	A	A	A	I.L	A	A	A	A
氯乙烷	C	C	A	A	A	A	A	A	A	A	A	B	B	I.L
乙烯	A	A	A	A	A	A	A	A	A	A	A	A	A	A
乙二醇	A	A	A	A	A	A	I.L	I.L	A	I.L	A	A	A	A
氯化铁	C	C	C	C	C	C	C	B	A	A	B	C	C	A
甲醛	B	B	A	A	A	A	A	A	C	A	A	A	A	I.L
甲酸	I.L	C	B	B	A	A	A	A	A	C	B	C	C	B
氟利昂 (湿的)	B	B	B	B	A	A	A	A	A	A	A	I.L	I.L	I.L
氟利昂 (干的)	B	B	A	A	A	A	A	A	A	A	A	I.L	I.L	I.L
糖醛	A	A	A	A	A	A	A	A	A	A	A	B	B	I.L
汽油 (精致的)	A	A	A	A	A	A	A	A	A	A	A	A	A	A

Valve Material Selection Table

葡萄糖	A	A	A	A	A	A	A	A	A	A	A	A	A	A
盐酸 (充气的)	C	C	C	C	C	C	A	B	C	C	B	C	C	C
盐酸 (无气的)	C	C	C	C	C	C	A	B	C	C	B	C	C	C
氢氟酸 (充气的)	B	C	C	B	C	C	A	A	B	C	B	C	C	C
氢氟酸 (无气的)	A	C	C	B	C	A	A	A	B	A	I.L	C	C	I.L
氢	A	A	A	A	A	A	A	A	A	A	A	A	A	A
过氧化氢	I.L	I.L	A	A	C	A	B	B	B	B	I.L	B	B	I.L
硫化氢 (液体)	C	C	A	A	C	C	A	A	A	A	A	C	C	I.L
氢氧化镁	A	A	A	A	B	A	A	A	A	A	A	A	A	I.L
汞	A	A	A	A	C	B	A	A	A	A	A	A	A	B
甲醇	A	A	A	A	A	A	A	A	A	A	A	A	A	A
甲乙酮	A	A	A	A	A	A	A	A	A	I.L	A	A	A	A
牛奶	C	C	A	A	A	A	A	A	A	C	A	C	C	C
天然气	A	A	A	A	A	A	A	A	A	A	A	A	A	A
硝酸	C	C	A	A	C	C	C	A	B	A	C	C	C	C
油酸	C	C	A	A	B	A	A	A	A	A	A	A	B	I.L
草酸	C	C	B	B	B	B	A	A	A	B	B	B	B	I.L
氧	A	A	A	A	A	A	A	A	A	A	A	A	A	A
石油 (精致的)	A	C	A	B	A	A	A	A	A	A	A	A	A	A
磷酸 (充气的)	C	C	A	A	C	C	B	B	B	B	A	C	C	I.L
磷酸 (无气的)	C	C	A	A	C	B	A	A	A	B	A	C	A	I.L
磷酸蒸汽	C	C	A	A	C	C	A	I.L	A	B	C	C	A	I.L
苦味酸	C	C	A	A	C	C	A	A	A	I.L	I.L	B	C	I.L
氯化钾	B	B	B	B	B	B	A	A	A	A	I.L	C	A	I.L
氢氧化钾	B	B	A	A	B	A	A	A	A	A	I.L	B	C	I.L
丙烷	A	A	A	A	A	A	A	A	A	A	A	A	A	A
松香	B	B	A	A	A	A	A	A	A	I.L	A	A	A	A
硝酸银	C	C	A	A	C	C	A	A	A	A	B	B	B	I.L
醋酸钠	A	A	B	A	A	A	A	A	A	A	A	A	A	A
碳酸钠	A	A	A	A	A	A	A	A	A	A	A	B	B	A
氯化钠	C	C	B	B	A	A	A	A	A	A	A	B	B	B
铬酸	A	A	A	A	A	A	A	A	A	A	A	A	A	A
氢氧化钠	A	A	A	A	A	A	A	A	A	A	A	B	B	A
次氯化钠	C	C	C	C	B-C	B-C	C	A	B	A	I.L	C	C	I.L
硫代硝酸钠	C	C	A	A	C	C	A	A	A	A	I.L	B	B	I.L
氯化亚锡	B	B	C	A	C	B	A	A	A	A	I.L	C	C	I.L
硬脂酸	A	C	A	A	B	B	A	A	A	A	A	B	B	I.L
硫酸盐溶液 (黑的)	A	A	A	A	C	A	A	A	A	A	A	I.L	I.L	I.L
硫	A	A	A	A	C	A	A	A	A	A	A	A	A	A
二氧化硫 (干的)	A	A	A	A	A	A	B	A	A	A	A	B	B	I.L
二氧化碳 (干的)	A	A	A	A	A	A	B	A	A	A	A	B	B	I.L
硫酸 (充气的)	C	C	C	C	C	C	A	A	A	B	B	C	C	C
硫酸 (无气的)	C	C	C	C	B	B	A	A	A	B	B	C	C	C
亚硫酸	C	C	B	B	B	B	A	A	A	A	A	C	C	I.L
焦油	A	A	A	A	A	A	A	A	A	A	A	A	A	A
三氯乙烯	B	B	B	A	A	A	A	A	A	A	A	B	B	I.L
松节油	B	B	A	A	A	B	A	A	A	A	A	A	A	A
醋	C	C	A	A	C	A	A	A	A	I.L	A	C	C	A
水 (锅炉给水)	B	C	A	A	A	A	A	A	A	A	A	B	A	A
水 (蒸馏的)	A	A	A	A	B	A	A	A	A	A	A	B	B	I.L
海水	B	B	B	B	B	A	A	A	A	A	A	C	C	I.L
威士忌和葡萄酒	C	C	A	A	A	B	A	A	A	A	A	C	C	I.L
氯化锌	C	C	C	C	C	C	A	A	A	A	B	C	C	I.L
硫酸锌	C	C	A	A	B	A	A	A	A	A	A	B	B	I.L

符号 A-能够或正被成功的应用; B-应用过程应注意; C-不能应用; I.L-缺乏资料

摘自《调节阀手册》第二版 美国仪表协会 J.W. 哈奇森 主编 林秋鸿等译 1984年 12月

本表是用来大致指出与每种物体接触而发生反应时, 应如何选择适当的材料。表中的推荐不是绝对的, 因为材料的耐腐蚀性与流体的速度、温度、压力和杂质等因素有关。因此, 必须强调本表只能作为一个导航。

材料中-英文对照表: 蒙乃尔合金-Monel; 哈氏合金 B(C)-Hastelloy” B” (”C”); 不锈钢 #20-Durimet20; 钴-铬合金 E#6-Alloy(Co-Cr)



E-mail: info@dbv-armaturen.com

www.dbvvalve.com

www.dombor.com

Tel: +86-577-67387723

Fax: +86-577-67383000

Add: No.96 Fanhua East Road, OuBei, WenZhou, Zhejiang, China



DBV Web



Dombor Web



linkedin



instagram



youtube



facebook

This manual is printed on eco-paper!

Due to the continuous innovation of technology and process of "DBV" products, this information is for reference only. Our company reserves the right of final interpretation.

"DBV" and "dombor" are registered trademarks of "DBV Valve Co.,Ltd" All rights reserved. Copies must be investigated!