

# Gate Valve、Globe Valve Check Valve

Product Brochure



## Company Profile

Company Profile

DBV Valve Co., Ltd. was established in 2001 and is headquartered in Oubei, Yongjia, Zhejiang, the hometown of pumps and valves in China. It is a modern enterprise integrating the manufacture, sales and service of various intelligent control valves (pneumatic, electric and hydraulic control). We have a factory building area of more than 20,000 square meters, more than 200 sets of machine equipment and more than 300 employees.

The company has been awarded the titles of National High-Tech Enterprise, A-class Tax Credit Enterprise of Zhejiang Province, and Star Enterprise of Yongjia County, etc. It has also been certified by American Petroleum Institute (API), Customs Union TR Declaration (EAC), German Technical Supervision Association (TUV) and Det Norske Veritas (DNV).

The company mainly produces high pressure severe service products and metal to metal seat butterfly valves, metal to metal seat ball valves, low temperature valves, etc., which are manufactured strictly according to ISO, ANSI, API, GB, HG and other standards. We have advanced physical and chemical testing centre, professional CNC machining and test pressure automatic production equipment and experienced technical production team. Product pressure from 150LB-2500LB, 0.6 MPA-42.0MPA, temperature resistance -196°C - 800°C.



Valve Production Workshop



Company Headquarters (Under Construction)



Frontline Staff

**2001**

Open

Year of Establishment

**2016**

International

International Trade Business

**2018**

New

Pump and Valve Base

**2021**

Certified

National Certification

**2023**

Now

Choose Us For Quality

Relying on our strict quality management system, our products are widely used in petroleum, petrochemical, natural gas, coal chemical, metallurgy, electric power and other industries, and exported to Europe, America, Asia Pacific, the Middle East and other countries and regions, the company has been approved by Oman National Oil Company, Iran South Oil Company, Thailand National Power Plant, Russia National Oil Service and other large international terminal customers.

In terms of research and manufacturing, the company has a number of senior R & D teams, advanced manufacturing equipment, perfect physical and chemical testing and inspection methods (spectrometer, helium mass spectrometer, high and low temperature comprehensive performance test equipment, etc.), scientific information management system (integrated PDM, ERP, CAD, CAPP), comprehensive resources to provide customers with sustainable product solutions and collaborative service support.

As a fluid control solutions provider, the company is committed to innovation and service enhancement and is constantly striving to become one of the world's most professional, comprehensive and reliable valve manufacturers.

## Equipment & Professional Team

Equipment & Professional Team

**20<sup>+</sup>**

Years

Manufacturing Experience

**200<sup>+</sup>**

Units

Manufacturing Facilities

**300<sup>+</sup>**

People

Practitioners

**3**

Teams

R&d Team

**20000<sup>+</sup>**

Square Metres

Intelligent Factory Floor Space

More Than 20 Years Of Experience In R&d And Production Exported To More Than 30 Countries And Regions Worldwide.

200 + Sets Of Intelligent Manufacturing Equipment	20 + Years Of Experience In R&d And Production	Exported To 30 + Countries Worldwide
4000 + Square Metres Of Finished Goods Warehouse	Over 300 Valve Practitioners	3 Valve Production Bases
Annual Production Of Over 8000 Tons Of Valves	3 Senior Valve R&d Teams	Intelligent And Scientific Production
20,000 + Square Metres Of Factory Floor Space	Professional Multilingual Sales Staff	.....



## Customers & Partners

Customers & Partners



DBV Valve Co., Ltd. is a fluid control solution provider that has been developing and producing ball valves and butterfly valves in China for more than 20 years. Our sales and service network extends to dozens of overseas countries and regions, and our end products are used by companies such as Petronas, Anadarko, Petrobras, Lukoil.

The company has been approved as a qualified supplier by large international terminal customers such as Oman National Oil Company, Iran National South Oil Company, Thailand National Power Plant and Russia National Oil Company.



## Honors & Qualifications

### Honors And Qualifications

Qualification is the guarantee of an enterprise's products, and honour is the silent motivation of an enterprise.

In terms of product standards and quality, the company has obtained the "API6D, API609 Valve Production Design Standard Certification" issued by the American Petroleum Institute API, the "API6FA, API607 Valve Fire Test Certificate", the "SIL-3 Safety Equipment Integrity Level Certificate" issued by the German Technical Supervision Association TUV, the CE Certificate, the "ATEX Explosion Test Certificate" issued by the Norwegian Classification Society DNV and many other international certifications.

The company was awarded the title of national high-tech enterprise, the title of science and technology-based small and medium-sized enterprise in Zhejiang Province, the title of star enterprise in Yongjia County for three consecutive years, the excellent supplier of government procurement and many other honorary titles.

DBV valves are manufactured in accordance with the ISO 9001 quality management system and are subject to 48 production processes, comprehensive testing and inspection in accordance with international standards, thus guaranteeing the high quality of DBV valves.



### DBV Certificates

API 6D	API 609	CE
ISO 9001	ISO 45001	ISO 14001
API 6FA/607	ISO 15848-1/API624	BS 6364
SIL-3 Ball Valve	SIL-3 Butterfly Valve	SIL-3 Control Valve
TR CU 032	TR CU 012	TR CU 010
MSK-64 Ball Valve	MSK-64 Butterfly Valve	ATEX

## Multi-Field Application Solutions

Multi-Field Application Solutions

Since its inception, DBV Valve has always been deeply involved in the valve field, with scientific and cutting-edge R&D and production processes, providing reliable, safe and economical fluid control solutions to customers worldwide in a variety of industries. With years of customization of fluid control solutions, DBV Valve has developed and produced a series of valves for various industries worldwide, including but not limited to: fine chemical industry, coal chemical industry, marine industry, new energy field, oil refining and petrochemical industry, metallurgical and mining industry, pharmaceutical and pesticide industry, nuclear power industry .....

### Industry-wide, Multi-type Fluid Control Solutions

Fine chemical industry	New Energy Sector	Pharmaceutical And Pesticide Industry
Coal chemical industry	Oil Refining And Petrochemical Industry	Nuclear Power Industry
Marine Marine Industry	Metallurgical And Mineral Industries	Technology And Environmental Industry



# Gate, Globe, Check Valve

## STANDARD FEATURES OF DBV CAST STEEL VALVES

### LOW FUGITIVE EMISSION SERVICE

DBV standard Cast Steel Gate, Globe and Check Valves are designed and manufactured to ensure leakage of less than 100 ppm (parts per million) of volatile organic compounds. Extensive base line laboratory testing (static and cycle testing) has been performed establishing critical design parameters necessary to achieve low emission sealing in the DBV stem packing

seal area for Gate and Globe Valves and in the bonnet gasket sealing area (cover gasket for Check Valves). In-house testing procedure has been developed and is periodically performed to ensure that standard product design and manufacturing criteria consistently result in the DBV Gate, Globe and Check Valve meeting a maximum of 100 ppm VOC leakage prior to shipment.

### CRITICAL DESIGN AND MANUFACTURING CONTROLS APPLIED TO PRODUCE LOW EMISSION SERVICE VALVES IN DBV STANDARD PRODUCTS.

- Stem Straightness and Roundness
- Stem Surface Finish To Max. 32 Ra
- Stuffing Box Surface Finish To Max. 125 Ra
- Stuffing Box and Gland Cylindricity
- Self Centering Gland Design
- Gland Packing: Die-formed Graphite Rings with Braided Graphite Top and Bottom Rings.
- Bonnet Gaskets:
  - Class 150 Gate: 316 SS Tanged Clad Graphite
  - Class 150 Globe & Check: 316 SS Spiral Wound Grafoil
  - Class 300 Valves: 316 SS Spiral Wound
  - Class 600 & Higher: Ring Type Joint

### LOW EMISSION DESIGN OPTIONS LIVE LOAD PACKING

In services requiring frequent cycling or with high pressure/temperature variations, live loading extends the service life between maintenance periods by requiring less frequent packing gland adjustments. Belleville springs are employed to provide constant packing gland stress.

#### Lantern Ring and Double Packing Set

Lantern ring with leak-off fitting connection and double packing stack is optionally available for critical services.

### PACKING SYSTEM

DBV Cast Steel Gate and Globe valves use a combination of dieformed flexible graphite and interbraided graphite in a predetermined arrangement to ensure an effective seal. Graphite packing achieves its maximum ability to isolate the atmosphere when it is contained within a chamber that is precise in finish

and dimension. DBV Gate and Globe valves are manufactured with stem finishes better than 32 Ra and stuffing box wall finishes for 125 Ra. In addition, stem straightness and taper are closely controlled.

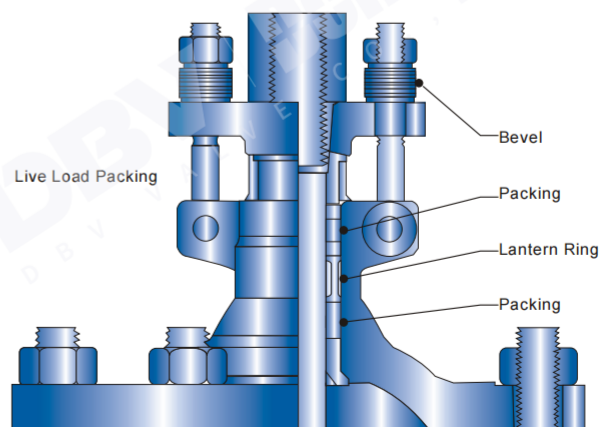
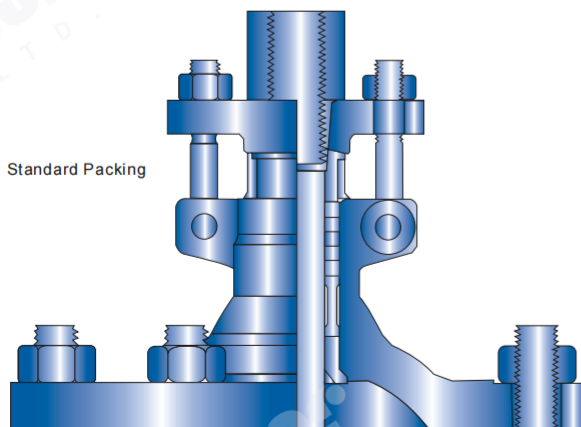

## AVAILABLE MODIFICATIONS FOR DBV CAST STEEL VALVES

Packing and Gasket Changes	Weld End Bore Changes
End Connection Modifications	Customer Specified Coatings
Gear Operator Mounting	Outside Lever and Weight for Check Valves
Trim Changes	Slam Retarders for Check Valves
Actuation	Chain Wheel Operator
Cryogenic Gas Columns	Block and Bleed
Hand Wheel Extensions	NDE Testing Available
Teflon Disc Inserts	Dye Penetrant Test
Drilled & Tapped Body/Bonnet Connections	Magnetic Particle Test
By-Pass	Radiography
Pressure Equalizing	PMI (Positive Material Identification)
Acid Shields	API Performance Testing
Oxygen & Chlorine Cleaning & Packaging	

## BODY/BONNET MATERIALS

DBV cast steel valves are available in a wider range of body/bonnet materials and optional trim materials. Listed below are some of the more popular materials. Additional materials are available. Please contact DBV or your local distributor for details.

DBV Material Designation	Common Description	ASTM Specs.	Body/Bonnet Material Service Limitations
WCB	Carbon Steel	A216	Non-corrosive service water, oil, & gases at temperatures between -20° F & +800° F
LCC	Low Temp Carbon	A352	Low temperature service between -50° F & +650° F
WC6	1.25% Chrome & .5% Moly	A217	Non-corrosive service water, oil, & gases at temperatures between -20° F & +1100° F
WC9	2.25% Chrome & 1% Moly	A217	Non-corrosive service water, oil, & gases at temperatures between -20° F & +1100° F
C5	5% Chrome & .5% Moly	A217	Corrosive, non-corrosive, or erosive service at temperatures between -20° F & +1200° F
C12	9% Chrome & 1% Moly	A217	Corrosive, non-corrosive, or erosive service at temperatures between -20° F & +1200° F
C12A	9% Chrome, 1% Moly, & V	A217	Corrosive, non-corrosive, or erosive service at temperatures between -20° F & +1200° F
C8M	Cast 316	A351	Corrosive, cryogenic or high temperature service between -450° F & +1200° F
A20	Alloy 20	A351	Corrosive service at temperatures between -20° F & +300° F

## TRIM MATERIALS THE FOLLOWING ARE DBV STANDARD TRIM DESIGNATIONS.

DBV Trim Number	Common Name	API 600 Trim No.	Seat Ring Facing (1)	Wedge or Disc Facing (1)	Stem	Other Trim Parts (2)	Service Limitations
1	13 Chrome	1	CR 13	CR 13	CR 13	CR 13	Non-corrosive applications. Steam, gas, & general service to 700° F. Oil & oil vapor to 900° F
2	Half Stellite	8	HF	CR 13	CR 13	CR 13	Steam, gas, & general service to 1000° F. Standard trim for gate valves
3	Full Stellite	5	HF	HF	CR 13	CR 13	Premium trim service to 1200° F. Excellent for high pressure water and steam service
4	316	10	316	316	316	316	Corrosive services to 850° F. Low temperature service standard for 316 SS valves
4/3	316/Half Stellite	12	HF	316	316	316	
5	316/Full Stellite	16	HF	HF	316	316	
5/2	Monel	9	NiCu	NiCu	NiCu	NiCu	Corrosive services to 750° F
5/3	Monel/Half Stellite	11	HF	NiCu	NiCu	NiCu	
6	Monel/Full Stellite	-	HF	HF	NiCu	NiCu	
7	Alloy 20	13	A20	A20	A20	A20	Corrosive services to 300° F
7	Bronze	-	BRZ	BRZ	BRZ	BRZ	Water, gas, or low pressure steam to 450° F
A7	Aluminum Bronze	-	AL BRZ	AL BRZ	AL BRZ	AL BRZ	
8	Iron	-	Iron	Iron	STL	Iron or STL	
X	Special	Special	Special	Special	Special	Special	Customer to specify

(1) Facing is defined as the seating surface of a seat ring and wedge/disc

(2) Other trim parts are defined as small internal parts that are normally in contact with the service fluid. This includes the stem, backseat bushing in gate and globe valves and the swing check disc nut



# Gate, Globe, Check Valve

## AUXILIARY CONNECTION LOCATIONS (BYPASSES, DRAINS, ETC.)

Please refer to ASME B16.34 for exact auxiliary connection locations, sizes, and threading information.

Each letter in the illustration(s) identify the possible hole locations for auxiliary connection(s). These illustrations are for reference purposes only.

Unless specified otherwise, auxiliary connection hole sizes shall be drilled and tapped as follows:

- 2" thru 4" utilizes a .50" hole
- 5" thru 8" utilizes a .75" hole
- 10" and larger utilizes a 1" hole

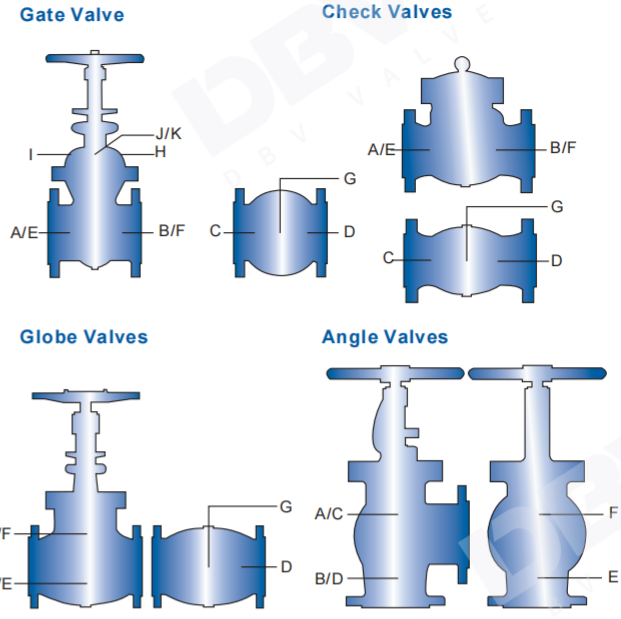

## O-RING SEAL BLOCK & BLEED GATE VALVES

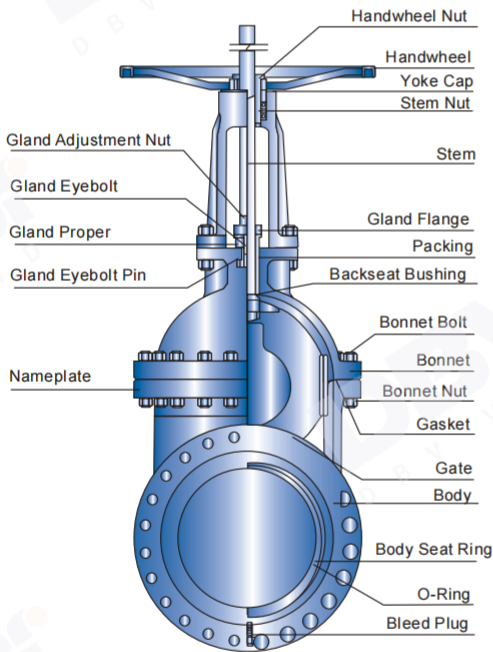

### FIRE SAFE, VAPOR TIGHT SHUT-OFF

Should fire occur burning or damaging the O-Ring seal, metal to metal seats will provide an effective fire-safe shut-off.

### SERVICE RECOMMENDATIONS

DBV O-Ring Seal Block and Bleed Gate Valves are recommended for hard to hold services such as butane, kerosene, gasoline, propane, diesel oils, fuel oils, jet fuels, steam, air, natural gas, toluene, hydrogen, helium, and oxygen. Manifold tank farms, LPG areas, and airport fueling facilities provide excellent opportunities for savings with the O-Ring Seal Gate Valves. For effective double block and bleed service, the line media should be free of foreign matter and solids in suspension.

### DESIGN FEATURES

The dovetail groove feature in the seating ring holds the O-Ring seal in place while allowing it to expand or contract during service and still maintains the proper compression to provide uniform sealing.

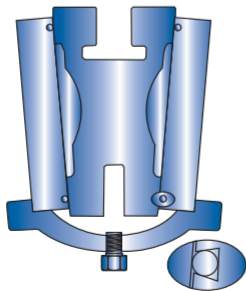

The precision ground metal to metal seats with the O-Ring feature as secondary seal provides dual seating and eliminates any media contamination.

A bleed plug is provided at position G to verify shut-off.

### SEAT MATERIALS

Teflon is considered our standard. It is the most widely used elastomer because of its resistance to corrosive and abrasive conditions. We can also offer other materials. Seat insert materials should be specified along with actual service conditions when ordering.

Type	Temperature Operating Range
Teflon	-100° F +400° F
PTFE	

## CAST STEEL CRYOGENIC GATE, GLOBE AND CHECK VALVES

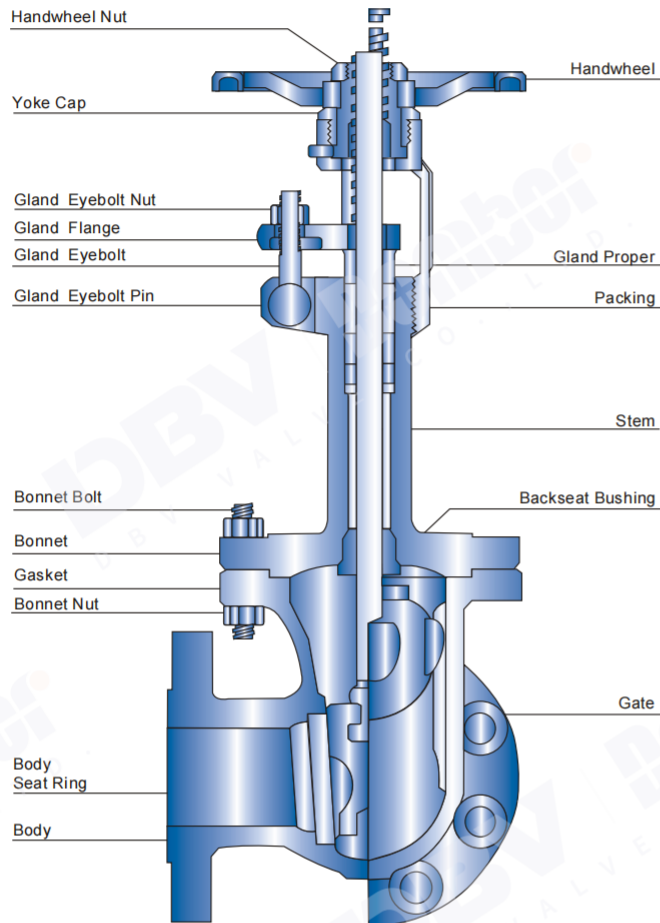

DBV Cryogenic Valves are manufactured to the latest edition of API Standard 600 and/or 603 and tested to API Standard 598.

### APPLICATION & FUNCTION

During the processes of production, transportation, storage and usage of liquefied gases, countless technical problems can be experienced. DBV cryogenic valves are designed to assure safety and reliability under these critical conditions.

All of DBV cryogenic valves are thoroughly cleaned and deoiled. Afterwards the end ports are sealed to prevent contamination. This process is performed in an approved and designated clean room.

### BODY & BONNET

The design of the body and bonnet is calculated to achieve the most regular distribution of stress in all directions, as well as the minimum turbulence and resistance to flow.

The extended bonnet provides a gas column which thermally isolates the stem packing and stem nut from the extreme temperatures so they remain functional. Usually the customer specifies the column length.

The body-bonnet joint is bolted using applicable ASTM specified bolting for low temperature/cryogenic conditions.

### GASKET

We can supply any style of gasket required by your customer; however, we recommend gaskets that are oxygen compatible.

### CLOSURES

**GATE VALVES** - All gates are fully guided to the seats. As standard, our valves are supplied with a stellite faced, solid flexible gate that has a tapered H cross-section. The flexible wedge is cast or machined with a circumferential groove to allow the seating surfaces to move independently and adjust to movement of the body seats.

**GLOBE VALVES** - The valve is normally supplied with the plug type disc. The disc rotates freely on the stem and incorporates a differential angle from that on the seating. This design provides the maximum assurance of shut off, is less likely to stick in the body seat and is considered the simplest design for field repair. Bottom guided discs are available.

**CHECK VALVES** - Each disc's seating surface is precision ground and mated to the seat ring for insurance of a positive shut off. The disc is bolted to the hinge arm and pinned to prevent disengagement during service.

Other soft inserts are available upon request.

# Gate, Globe, Check Valve

## DBV CAST STEEL BOLTED BONNET GATE VALVE EXPANDED VIEW

1. Body: DBV cast steel bodies provide low resistance flow and optimum strength and performance.
2. Yoke & Bonnet: DBV bonnet assemblies are built to the same standards as the bodies. Larger size gate valves utilize a multi-piece bonnet design.
3. Grease Fitting: The grease fitting allows for easy system lubrication.
4. Stem: The stem is precision machined and inserts into the horizontal channel in the disc.
5. Wedge: DBV 1-piece flex wedge is machined to the tightest tolerances to ensure trouble free shut off and cycling.
6. Back Seat Bushing: The back seat, when engaged with the stem head, provides a stable shut off to the stuffing box which isolates the packing from flow exposure.
7. Gland: Compresses the packing to create a stem seal above the back seat, between the bonnet and stem.
8. Gland Flange: Applies pressure to the gland for accurate packing adjustments.
- 9 & 10. Gland Bolts & Nuts: The gland bolt and nut allows for easy adjustments for packing compression.
11. Gland Bolt Pin: The gland bolt pin secures the gland bolts to the yoke & bonnet.
12. Packing: The packing creates a seal above the back seat, between the bonnet and stem.
13. Stuffing Box: The stuffing box contains the packing.
14. Stem Nut: The stem nut provides a precision guide for proper stem alignment.
15. Yoke Bushing: The retaining nut secures the stem nut to the bonnet assembly.
16. Handwheel: The handwheel cycles the valve.
17. Handwheel Nut: The handwheel nut secures the handwheel to the bonnet assembly.
18. Set Screw: The set screw prevents handwheel nut loosening.
19. Bonnet Gasket: The bonnet gasket creates a leak proof seal between the bonnet and body.
- 20 & 21. Bonnet Studs & Nuts: The bonnet studs and nuts secure the bonnet to the body.
22. Seat Rings: To ensure a stable shut off, seat rings are aligned and seal-welded into the valve, then precision ground for optimal seating.
23. Spacer Ring: Assists the packing rings in creating a seal above the back seat, between the bonnet and stem.

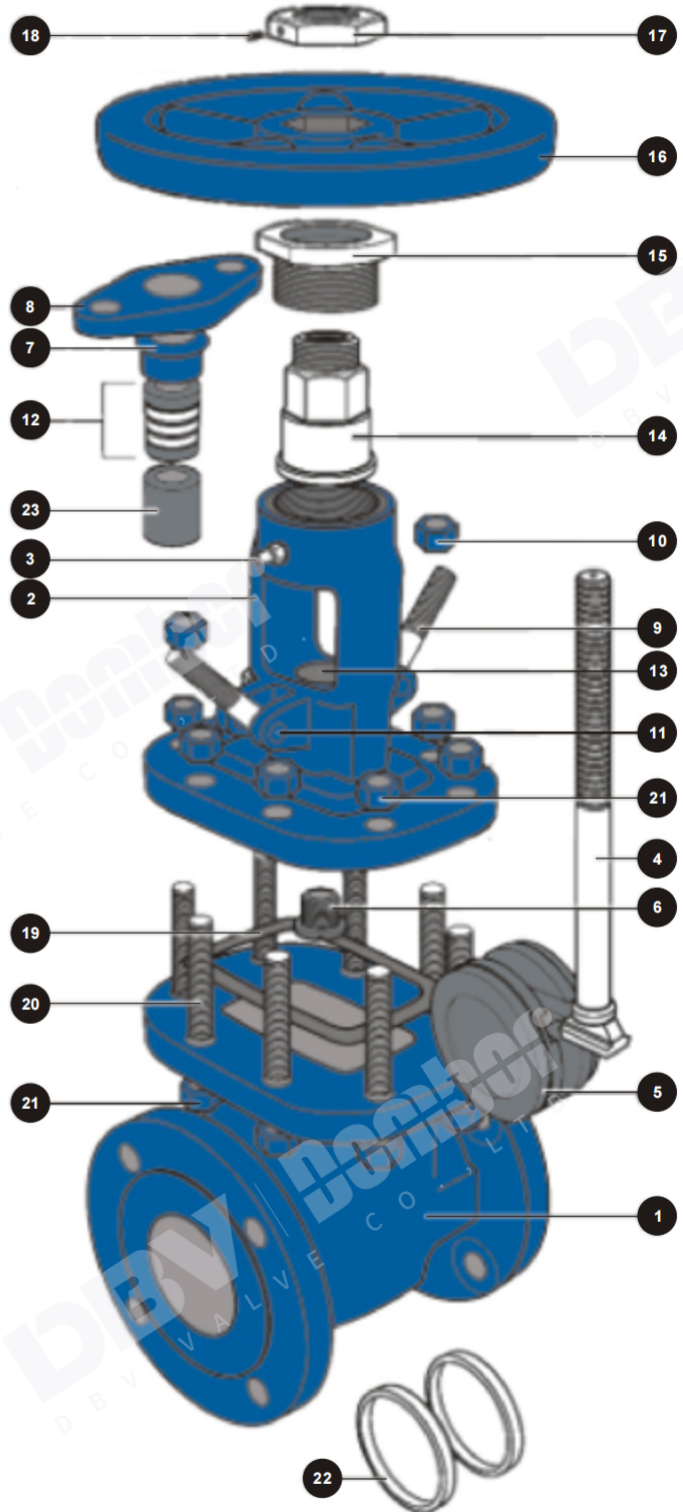

## CAST STEEL GATE VALVES

### STANDARD PARTS AND MATERIALS

NO.	PART NAME	CARBON STEEL			ALLOY STEEL			STAINLESS STEEL
		TYPE WCB	TYPE LCB	TYPE WC6	TYPE WC9	TYPE C5	TYPE C12	TYPE CF8M
1	BODY	A216-WCB	A352-LCB	A217-WC6	A217-WC9	A217-C5	A217-C12	A351-CF8M
2	BONNET	A216-WCB	A352-LCB	A217-WC6	A217-WC9	A217-C5	A217-C12	A351-CF8M
3	GATE	A217 CA15 or WCB+410	A351 CF8M or LCB+316	A217 CA15 or WCB+410	A217 CA15 or WC9+410	A217 CA15 or C5+410	A217 CA15 or C12+410	A351-CF8M
4	SEAT RING	A576-1020+STL	A182-316	A182 F11+STL	F22+STL	F5a+STL	F9+STL	A479-316
5	YOKE	A216WCB	LCB/WCB	WC6/WCB	WC9/WCB	C5/WCB	C12/WCB	A351-CF8
6	HANDWHEEL	A197 or WCB	A197 or WCB	A197 or WCB	A197 or WCB	A197 or WCB	A197 or WCB	A197 or WCB
7	STEM	A479-410	A479-316	A479-410	A479-410	A479-410	A479-410	A479-316
8	BACKSEAT BUSHING	A479-410	A479-316	A479-410	A479-410	A479-410	A479-410	A479-316
9	GLAND FLANGE	A105	A105	A105	A105	A105	A105	A351-CF8
10	STEM NUT	A439-D2	A439-D2	A439-D2	A439-D2	A439-D2	A439-D2	A439-D2
11	GLAND PROPER	C/S 1020+Cr Plate	C/S 1020+Cr Plate	C/S 1020+Cr Plate	C/S 1020+Cr Plate	C/S 1020+Cr Plate	C/S 1020+Cr Plate	A479-316
12	YOKE CAP	C/S1020	C/S1020	C/S1020	C/S1020	C/S1020	C/S1020	A576-1020
13	BONNET BOLT	A193-B7	A320-L7	A193-B16	A193-B16	A193-B16	A193-B16	A193-B8
14	BONNET NUT	A194-2H	A194-4	A194-4	A194-4	A194-4	A194-4	A194-8
15	GLAND EYEBOLT	A307B	A307B	A193-B7	A193-B7	A193-B7	A193-B7	A193-B8
16	GLAND ADJUSTMENT NUT	A307B	A307B	A194-2H	A194-2H	A194-2H	A194-2H	A194-8
17	HANDWHEEL NUT	A47 Gr 32510	A47 Gr 32510	A47 Gr 32510	A47 Gr 32510	A47 Gr 32510	A47 Gr 32510	A47 Gr 32510
18	GLAND EYEBOLT PIN	C/S 1020	C/S 1020	C/S 1020	C/S 1020	C/S 1020	C/S 1020	A479-304
19	PACKING	Flex. Graphite	Flex. Graphite	Flex. Graphite	Flex. Graphite	Flex. Graphite	Flex. Graphite	Flex. Graphite
20	GASKET	Graphite + 304SS	Graphite + 304SS	Graphite + 304SS	Graphite + 304SS	Graphite + 304SS	Graphite + 304SS	Graphite + 316SS
21	YOKE BOLT	A193-B7	A193-B7	A193-B7	A193-B7	A193-B7	A193-B7	A193-B8
22	YOKE NUT	A194-2H	A194-2H	A194-2H	A194-2H	A194-2H	A194-2H	A194-8
23	NAMEPLATE	Stainless Steel	Stainless Steel	Stainless Steel	Stainless Steel	Stainless Steel	Stainless Steel	Stainless Steel

<sup>1</sup>Other materials available onrequest.

<sup>2</sup>STL = Stellite#6.

### CAST STEEL GATE VALVE

- Cast steel gate valve, outside screw and yoke,
- Bolted bonnet, rising stem, non-rising handwheel,
- Flexible wedge, available in welded or threaded seat rings,
- Designed according to API-600.

Face to Face	ASME/ANSI B16.10
End Flange	ASME/ANSI B16.5*
Buttweld	ASME/ANSI B16.25
Rating	ASME/ANSI Class 150

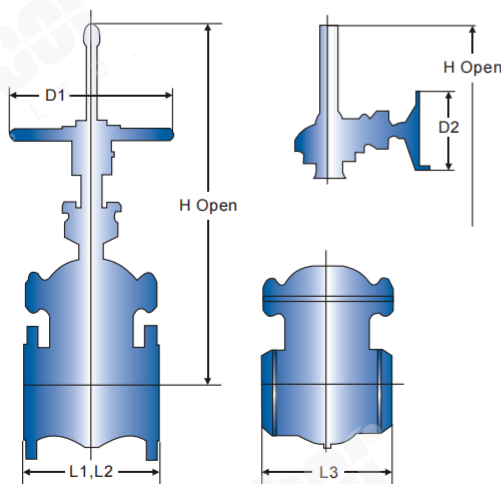

### CLASS 150 DIMENSION

SIZE (in.)	1-1/2"	2"	2-1/2"	3"	4"	6"	8"	10"	12"
L1: RF	6.50	7.00	7.50	8.00	9.00	10.50	11.50	13.00	14.00
L2: RTJ	7.00	7.50	8.00	8.50	9.50	11.00	12.00	13.50	14.50
L3: BW	6.50	8.50	9.50	11.13	12.00	15.88	16.50	18.00	19.76
H	12.76	14.45	15.63	18.03	22.05	30.04	37.80	45.91	53.90
D1	7.09	7.87	7.87	8.82	9.84	12.40	13.98	15.75	17.72
D2	-	-	-	-	12.40	12.40	12.40	13.98	15.75
W.T F	36	41	58	73	106	192	284	397	618
(lbs) BW	31	36	47	61	86	166	242	327	513

SIZE (in.)	14"	16"	18"	20"	24"	30"	36"
L1: RF	15.00	16.00	17.00	18.00	20.00	24.00	28.00
L2: RTJ	15.50	16.50	17.50	18.50	20.50	-	-
L3: BW	22.50	24.00	26.00	28.00	32.00	36.00	40.00
H	59.65	71.80	74.80	83.50	98.50	126.00	140.20
D1	19.69	22.05	24.80	27.95	31.50	35.43	43.00
D2	15.75	15.75	17.72	17.72	19.69	27.95	31.50
WT F	904	1,279	1,488	1,856	3,042	4,630	6,400
(lbs) BW	774	1,126	1,296	1,632	2,703	3,944	6,305

\* 26" and larger are available with ASME/ANSI B16.47 end flanges, either Style A or Style B (formerly MSS SP-44 and API 605).

# Gate, Globe, Check Valve

## CAST STEEL GATE VALVE

- Cast steel gate valve, outsidescrew and yoke,
- Bolted bonnet, rising stem, non-rising handwheel,
- Flexible wedge, available in welded or threaded seat rings,
- Designed according to API-600.

Face to Face	ASME/ANSI B16.10
End Flange	ASME/ANSI B16.5*
Buttweld	ASME/ANSI B16.25
Rating	ASME/ANSI Class 300

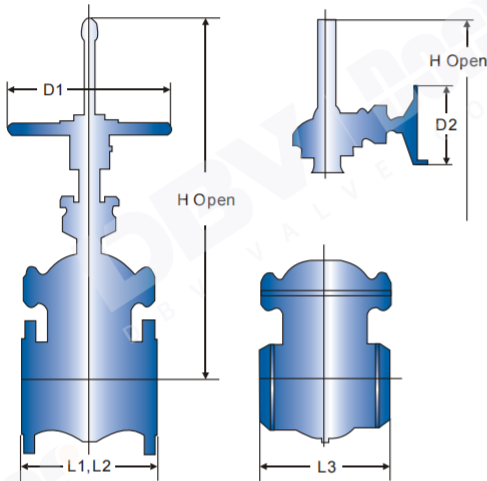

## CLASS 300 DIMENSION

SIZE (in.)	1-1/2"	2"	2-1/2"	3"	4"	6"	8"	10"	12"	Unit: inch
L1: RF	7.50	8.50	9.50	11.13	12.00	15.83	16.50	18.00	19.75	
L2: RTJ	8.00	8.13	10.13	11.83	12.63	16.50	17.13	18.63	20.38	
L3: BW	7.50	8.50	9.50	11.13	12.00	15.83	16.50	18.00	19.75	
H	15.00	15.94	17.32	19.69	23.31	32.13	41.02	48.31	56.77	
D1	7.87	7.87	7.87	8.82	9.84	13.98	15.75	17.72	19.69	
D2	-	-	-	-	12.40	12.40	12.40	13.98	15.75	
WT F	40	58	75	110	165	317	550	704	1,056	
(lbs)	29	49	60	84	119	251	462	561	808	

SIZE (in.)	14"	16"	18"	20"	24"	30"	36"	Unit: inch
L1: RF	30.00	33.00	36.00	39.00	45.00	55.00	68.00	
L2: RTJ	30.63	33.63	36.63	39.75	45.83	56.00	59.00	
L3: BW	30.00	33.00	36.00	39.00	45.00	55.00	68.00	
H	62.52	74.41	80.31	86.50	121.18	127.60	159.06	
D1	22.05	24.80	27.95	31.50	35.43	51.02	63.00	
D2	15.75	19.69	19.69	19.69	24.80	31.50	51.02	
WT F	1,496	2,139	2,772	3,545	5,346	8,316	16,698	
(lbs)	1,232	1,793	2,354	3,058	4,367	7,040	14,960	

\* 26" and larger are available with ASME/ANSI B16.47 end flanges, either Style A or Style B (formerly MSS SP-44 and API 605).

## CAST STEEL GATE VALVE

- Cast steel gate valve, outsidescrew and yoke,
- Bolted bonnet, rising stem, non-rising handwheel,
- Flexible wedge, available in welded or threaded seat rings,
- Designed according to API-600.

Face to Face	ASME/ANSI B16.10
End Flange	ASME/ANSI B16.5*
Buttweld	ASME/ANSI B16.25
Rating	ASME/ANSI Class 600

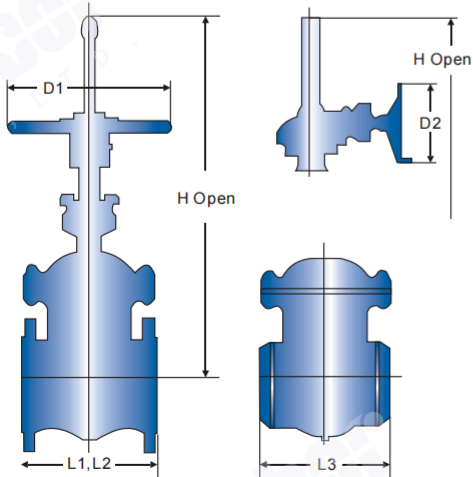

## CLASS 600 DIMENSION

SIZE (in.)	2"	2-1/2"	3"	4"	6"	8"	10"	12"	Unit: inch
L1: RF	11.50	13.00	14.00	17.00	22.00	26.00	31.00	33.00	
L2: RTJ	11.63	13.13	14.13	17.13	22.13	26.13	31.13	33.13	
L3: BW	11.50	13.00	14.00	17.00	22.00	26.00	31.00	33.00	
H	16.65	17.99	20.12	25.00	37.72	42.44	48.86	56.69	
D1	7.87	8.82	9.84	13.98	17.72	19.69	24.80	27.95	
D2	-	-	-	12.40	15.75	17.72	19.69	22.05	
WT F	80	113	143	277	532	935	1,385	1,984	
(lbs)	69	97	122	220	423	744	1,102	1,578	

SIZE (in.)	14"	16"	18"	20"	24"	30"	Unit: inch
L1: RF	35.00	39.00	43.00	47.00	55.00	65.00	
L2: RTJ	35.13	39.13	43.13	47.25	55.38	65.50	
L3: BW	35.00	39.00	43.00	47.00	55.00	65.00	
H	50.09	71.06	78.11	79.92	107.00	155.98	
D1	31.50	35.43	35.43	42.99	42.99	63.00	
D2	24.80	27.96	27.96	31.50	31.50	35.43	
WT F	2,658	3,108	4,891	6,197	8,656	14,840	
(lbs)	2,283	2,473	4,240	5,371	7,473	12,810	

\* 26" and larger are available with ASME/ANSI B16.47 end flanges, either Style A or Style B (formerly MSS SP-44 and API 605).

**CAST STEEL GATE VALVE**

- Cast steel gate valve, outsidescrew and yoke,
- Bolted bonnet, rising stem, non-risinghandwheel,
- Flexible wedge, available in weldedor threaded seat rings,
- Designed according to API-600.

Face to Face	ASME/ANSI B16.10
End Flange	ASME/ANSI B16.5
Buttweld	ASME/ANSI B16.25
Rating	ASME/ANSI Class 900

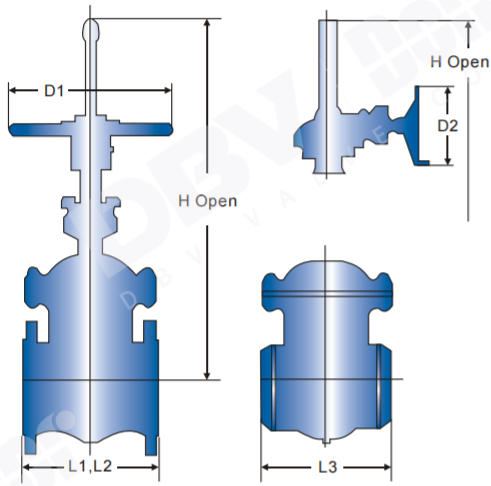

**CLASS 900 DIMENSION**

SIZE (in.)	2"	3"	4"	6"	8"	10"	12"	Unit: inch
L1: RF	14.50	15.00	18.00	24.00	29.00	33.00	38.00	
L2: RTJ	14.63	15.13	18.13	24.13	29.13	33.13	38.13	
L3: BW	14.50	15.00	18.00	24.00	29.00	33.00	38.00	
H	18.66	23.03	27.64	37.72	50.98	57.13	65.16	
D1	9.84	13.98	13.98	19.69	24.80	24.80	31.50	
D2	-	-	-	17.72	22.05	24.80	24.80	
W.T F (lbs)	178	219	307	750	1,279	1,963	3,160	
	165	191	251	641	1,113	1,552	2,670	

  

SIZE (in.)	14"	16"	18"	20"	24"	Unit: inch
L1: RF	40.50	44.50	48.00	52.00	61.00	
L2: RTJ	40.87	44.87	48.50	52.50	61.75	
L3: BW	40.50	44.50	48.00	52.00	61.00	
H	72.52	84.61	87.80	97.10	111.81	
D1	35.43	35.43	42.99	42.99	42.99	
D2	27.95	27.95	31.50	35.43	35.43	
W.T F (lbs)	4,395	5,940	7,662	9,620	14,454	
	3,740	5,078	6,534	8,010	12,117	

**CAST STEEL GATE VALVE**

- Cast steel gate valve, outsidescrew and yoke,
- Bolted bonnet, rising stem, non-risinghandwheel,
- Flexible wedge, available in weldedor threaded seat rings,
- Designed according to API-600.

Face to Face	ASME/ANSI B16.10
End Flange	ASME/ANSI B16.5
Buttweld	ASME/ANSI B16.25
Rating	ASME/ANSI Class 1500

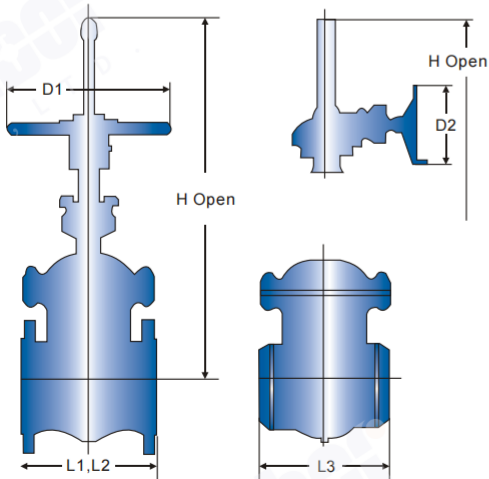

**CLASS 1500 DIMENSION**

SIZE (in.)	2"	3"	4"	6"	8"	10"	12"	Unit: inch
L1: RF	14.50	15.00	18.00	24.00	29.00	33.00	44.50	
L2: RTJ	14.63	18.63	21.63	28.00	33.13	39.37	45.13	
L3: BW	14.50	15.00	18.00	24.00	32.75	33.00	44.50	
H	18.66	23.74	28.70	37.17	53.50	57.13	67.13	
D1	9.84	13.98	13.98	19.69	24.80	24.80	35.43	
D2	-	-	17.72	17.72	27.95	27.95	27.95	
W.T F (lbs)	178	312	529	1,114	2,351	3,840	6,464	
	165	246	423	896	2,058	3,050	5,270	

SIZE (in.)	14"	16"	18"	20"	24"	Unit: inch
L1: RF	49.50	54.50	60.50	65.50	76.50	
L2: RTJ	50.25	55.37	61.37	66.37	77.63	
L3: BW	49.50	54.50	60.50	65.50	76.50	
H	74.49	90.12	93.31	104.96	119.69	
D1	35.43	35.43	35.43	35.43	-	
D2	31.50	35.43	35.43	42.99	42.99	
W.T F (lbs)	8,150	13,300	17,820	22,037	32,210	
	6,340	11,800	15,325	18,920	27,264	

# Gate, Globe, Check Valve

## PARALLEL SLIDING GATE VALVE

- Cast Steel Gate Valve, Outside Screw and York,
- Bolted Bonnet, Rising Stem, Flexible Wedge
- Parallel Double Disc, Double Expanding Sealed
- Designed to ASME B16.34

Face to Face	ASME/ANSI B16.10
End Flange	ASME/ANSI B16.5
Buttweld	ASME/ANSI B16.25
Class	ASME/ANSI CL150

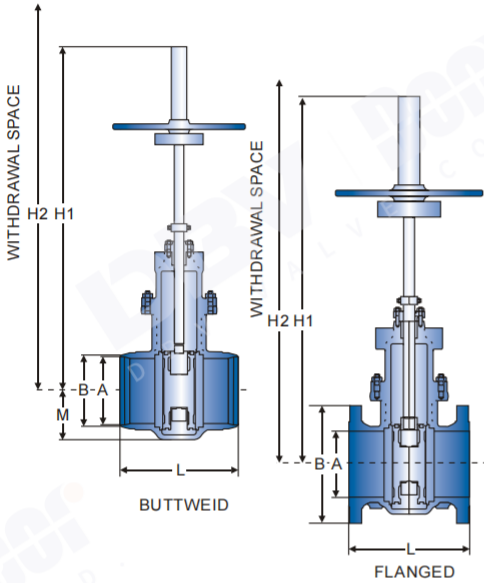

## CLASS 150 FLANGED

SIZE (in.)	A	B	H1	H2	L	W.T (lbs)
2-1/2	2-1/2	7	14-3/8	20-1/8	7-1/2	73
3	3	7-1/2	21-1/8	26-3/4	8	88
4	4	9	27	32-7/8	9	154
6	6	11	39-3/8	45-7/8	10-1/2	284
8	8	13 1/2	44-1/2	51-1/4	11-1/2	430
10	10	16	52-3/8	61-1/2	13	606
12	12	19	60-3/8	71-3/4	14	816
14	13.18	21	61-1/4	76	15	1120
16	15.16	23 1/2	66-5/8	79	16	1444
18	17.32	25	77-7/8	91-1/2	17	1852
20	19.10	27 1/2	85-3/8	99	18	2304
24	23.23	32	107	123	20	4400

## CLASS 150 BUTTWELD

SIZE (in.)	A	B	H1	H2	L	M	W.T (lbs)
2-1/2	2.36	3.54	14-3/8	20-1/8	9-1/2	2-3/4	71
3	2.91	3.50	21-1/8	26-3/4	11-1/8	3	79
4	3.81	5.12	27	32-7/8	12	3-5/8	139
6	5.87	7.28	38-5/8	45-7/8	15-5/8	5	306
8	7.60	9.44	44-1/2	51-1/4	16-1/2	6-3/8	370
10	9.60	11.42	52-3/8	61-1/2	18	7-1/2	551
12	11.61	13.58	60-3/8	71-3/4	19-3/4	8-3/4	701
14	12.99	15.35	61-1/4	76	22-1/2	9-3/4	1180
16	14.96	17.50	2000	79	24	10-3/4	1389
18	16.73	19.00	2315	91-1/2	26	11-7/8	2099
20	18.90	21.00	85-3/8	99	28	14-1/4	2503
24	22.64	25.60	107	123	31	15-3/8	3300

Withdrawal space shown refers to the valve being in the fully open position.

## PARALLEL SLIDING GATE VALVE

- Cast Steel Gate Valve, Outside Screw and York,
- Bolted Bonnet, Rising Stem, Flexible Wedge
- Parallel Double Disc, Double Expanding Sealed
- Designed to ASME B16.34

Face to Face	ASME/ANSI B16.10
End Flange	ASME/ANSI B16.5
Buttweld	ASME/ANSI B16.25
Class	ASME/ANSI CL300

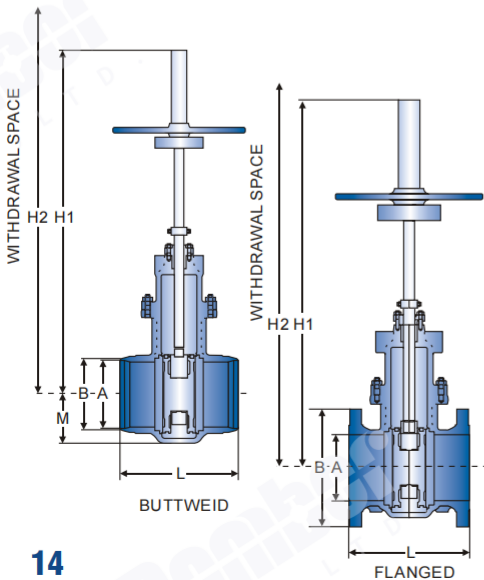

## CLASS 300 FLANGED

SIZE (in.)	A	B	H1	H2	L	W.T (lbs)
2-1/2	2 1/2	7 1/2	18 7/8	20 1/8	9 1/2	86
3	3	8 1/4	21 1/8	26 3/4	11 1/8	101
4	4	10	27	32 7/8	12	183
6	6	12 1/2	39 3/8	45 7/8	15 7/8	375
8	8	15	45	51 1/4	16 1/2	540
10	10	17 1/2	57 1/4	61 1/2	18	906
12	12	20 1/2	63	71 3/4	19 3/4	1345
14	13.18	23	67 1/4	76	22 1/2	1726
16	15.16	25 1/2	74 5/8	79	24	2223
18	16.93	28	81 7/8	91 1/2	26	3091
20	19.10	30 1/2	101	99	28	3407
24	23.03	36	120	123	31	4700

## CLASS 300 BUTTWELD

SIZE (in.)	A	B	H1	H2	L	M	W.T (lbs)
2-1/2	2.36	3.54	18-7/8	20-1/8	9-1/2	2-7/8	71
3	2.91	3.94	21-1/8	26-7/8	11-1/8	3	79
4	3.80	5.12	27	32-7/8	12	3-5/8	139
6	5.80	7.28	38-5/8	45-7/8	15-5/8	5	306
8	7.60	9.44	45	47-3/4	16-1/2	6-3/8	463
10	9.64	11.81	57-1/4	66-5/8	18	7-1/2	875
12	11.61	13.58	59	72-7/8	19-3/4	8-3/4	1147
14	12.48	15.47	67-1/4	78	22-1/2	10-1/8	1347
16	14.96	17.51	79	80	24	10-7/8	1715
18	16.73	19.50	95	96	26	12-1/4	2485
20	18.19	21.65	101	117-1/2	28	14-3/8	2712
24	22.64	25.60	112	132-1/2	31	16-3/8	3300

Withdrawal space shown refers to the valve being in the fully open position.

DBV VALVE CO., LTD.

## TYPICAL DBV CAST STEEL BOLTED BONNET GLOBE VALVE EXPANDED VIEW

1. Body: DBV cast steel bodies provide low resistance flow and optimum strength and performance.
2. Bonnet: DBV bonnet assemblies are built to the same standards as the bodies.
3. Back Seat Bushing: The back seat, when engaged with the stem head, provides a stable shutoff to the stuffing box which isolates the packing from flow exposure.
4. Stem: The stem inserts vertically into the disc.
5. Lock Groove: The lock groove receives the split lock ring which allows the disc nut to lift the disc during cycling.
6. Split Ring: The split ring allows the disc nut to lift the disc during cycling.
7. Disc: DBV plug type disc is machined to the tightest tolerances to ensure trouble free shutoff and cycling.
8. Disc Nut: The disc nut, in conjunction with the split lock ring, secures the disc to the stem.
9. Gland: Compresses the packing to create a stem seal above the back seat, between the bonnet and stem.
10. Gland Flange: Applies pressure to the gland for accurate packing compression.
- 11 & 12. Gland Bolts & Nuts: The gland bolt and nut allows for easy adjustments for packing compression.
13. Gland Bolt Pin: The gland bolt pin secures the gland bolts to the yoke & bonnet.
14. Packing: The packing creates a seal above the back seat, between the bonnet and stem.
15. Stuffing Box: The stuffing box contains the packing.
16. Stem Nut: The stem nut provides a precision guide for proper stem alignment.
17. Handwheel: The handwheel cycles the valve.
18. Handwheel Nut: The handwheel nut secures the handwheel to the bonnet assembly.
19. Handwheel Washer: The washer helps to prevent loosening or distributes pressure evenly.
20. Bonnet Gasket: The bonnet gasket creates a leakproof seal between the bonnet and body.
- 21 & 22. Bonnet Studs & Nuts: The bonnet studs and nuts secure the bonnet to the body.
23. Seat Ring: To ensure a stable shutoff, the seat rings are aligned and seal-welded into the valve, then precision ground for optimal seating.
24. Disc Guide: The disc guides provide a stable track for keeping the disc aligned with the seat during cycling.
25. Spacer Ring: Assists the packing rings in creating a seal above the back seat, between the bonnet and stem.

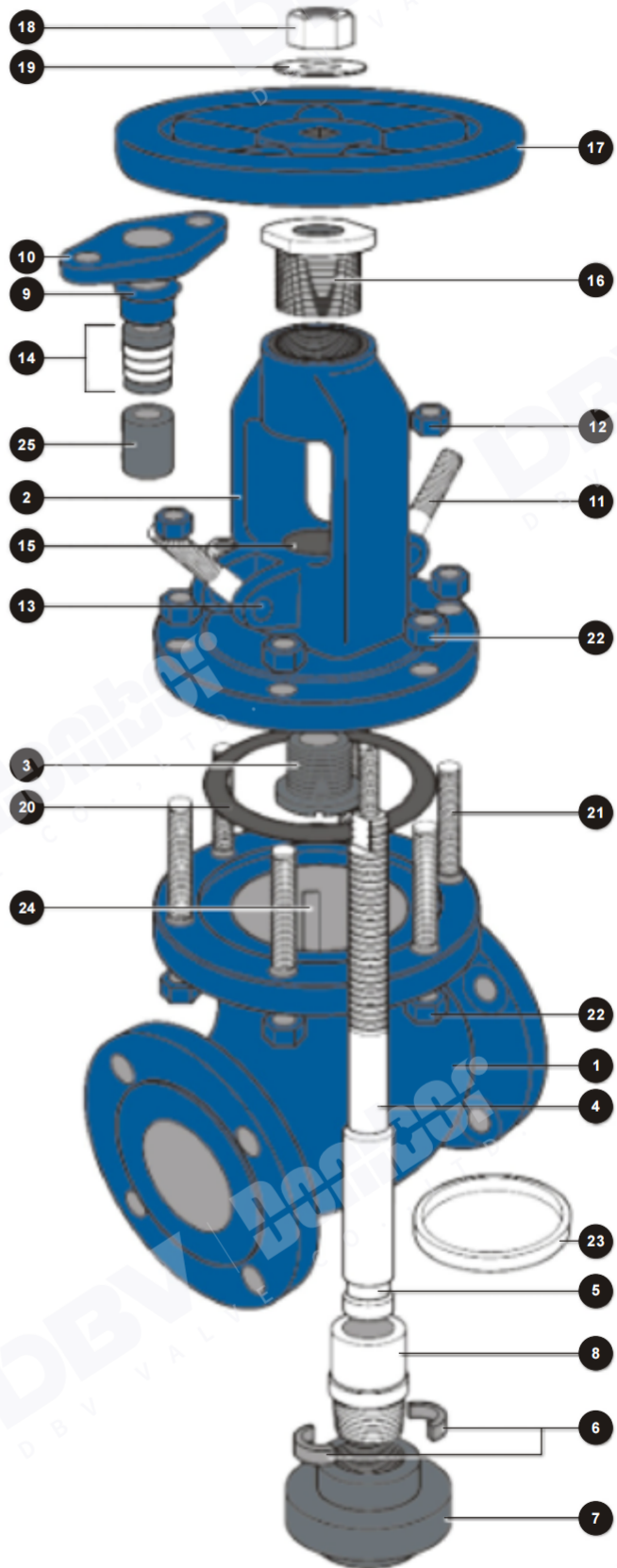



## Gate, Globe, Check Valve

### TYPICAL DBV CAST STEEL BOLTED BONNET ANGLE VALVE EXPANDED VIEW

1. Body: DBV cast steel bodies provide low resistance flow and optimum strength and performance.
2. Bonnet: DBV bonnet assemblies are built to the same standards as the bodies.
3. Back Seat Bushing: The back seat, when engaged with the stem head, provides a stable shutoff to the stuffing box which isolates the packing from flow exposure.
4. Stem: The stem inserts vertically into the disc.
5. Lock Groove: The lock groove receives the split lock ring which allows the disc nut to lift the disc during cycling.
6. Split Ring: The split ring allows the disc nut to lift the disc during cycling.
7. Disc: DBV disc is machined to the tightest tolerances to ensure trouble-free shutoff and cycling.
8. Disc Nut: The disc nut, in conjunction with the split lock ring, secures the disc to the stem.
9. Gland: Compresses the packing to create a stem seal above the back seat, between the bonnet and stem.
10. Gland Flange: Applies pressure to the gland for accurate packing compression.
- 11 & 12. Gland Bolts & Nuts: The gland bolt and nut allows for easy adjustments for packing compression.
13. Gland Bolt Pin: The gland bolt pin secures the gland bolts to the yoke & bonnet.
14. Packing: The packing creates a seal above the back seat, between the bonnet and stem.
15. Stuffing Box: The stuffing box contains the packing.
16. Stem Nut: The stem nut provides a precision guide for proper stem alignment.
17. Handwheel: The handwheel cycles the valve.
18. Handwheel Nut: The handwheel nut secures the handwheel to the bonnet assembly.
19. Handwheel Washer: The washer helps to prevent loosening or distributes pressure evenly.
20. Bonnet Gasket: The bonnet gasket creates a leakproof seal between the bonnet and body.
- 21 & 22. Bonnet Studs & Nuts: The bonnet studs and nuts secure the bonnet to the body.
23. Seat Ring: To ensure a stable shutoff, the seat rings are aligned and seal-welded into the valve, then precision ground for optimal seating.
24. Disc Guide: The disc guides provide a stable track for keeping the disc aligned with the seat during cycling.
25. Spacer Ring: Assists the packing rings in creating a seal above the back seat, between the bonnet and stem.

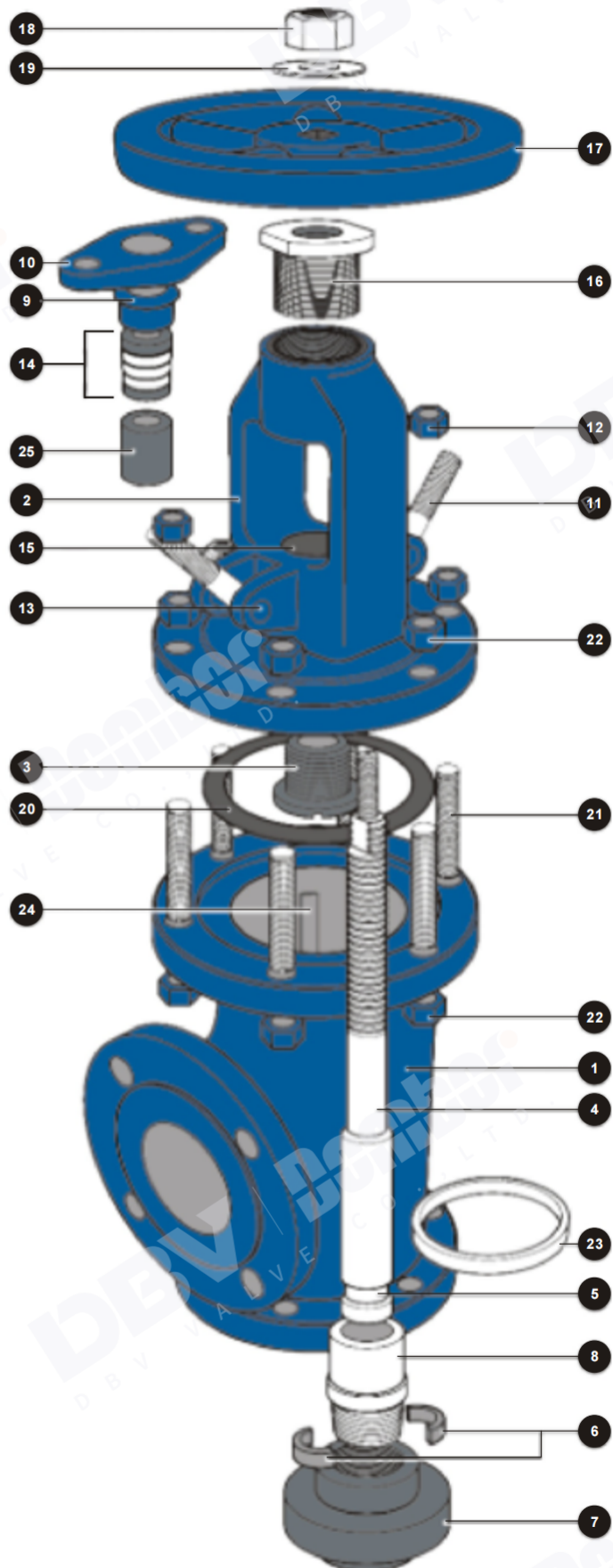

## CAST STEEL GLOBE AND ANGLE VALVES STANDARD PARTS AND MATERIALS

NO.	PART NAME	CARBON STEEL			ALLOY STEEL			STAINLESS STEEL
		TYPE WCB	TYPE LCB	TYPE WC6	TYPE WC9	TYPE C5	TYPE C12	TYPE CF8M
1	BODY	A216-WCB	A352-LCB	A217-WC6	A217-WC9	A217-C5	A217-C12	A351-CF8M
2	BONNET	A216-WCB	A352-LCB	A216-WC6	A217-WC9	A217-C5	A217-C12	A351-CF8M
3	DISC1	A217 CA15 or WCB+410	A351 CF8M or LCB+316	A217 CA15 or WCB+410	A217 CA15 or WCB+410	A217 CA15 or C5+410	A217 CA15 or C12+410	A351-CF8M
4	STEM	A479-410	A479-316	A479-410	A479-410	A479-410	A479-410	A479-316
5	HANDWHEEL	A216-WCB or A197	A216-WCB or A197	A216-WCB or A197	A216-WCB or A197	A216-WCB or A197	A216-WCB or A197	A216-WCB or A197
6	SEATING RING	C/S 1020+410	A182-F304	A182 F11+STL	A182 F5a+STL	A182 F9+STL	A182 F9+STL	A479-316
7	BACKSEAT BUSHING	A479-410	A479-304	A479-410	A479-410	A479-410	A479-410	A479-316
8	GLAND PROPER	C/S 1020+ CrPlate	A479-410	A479-410	A479-410	A479-410	A479-410	A479-316
9	GLAND FLANGE	A105 or A283-D	A105 or A283-D	A105 or A283-D	A105 or A283-D	A105 or A283-D	A105 or	A351-CF8
10	STEM NUT	A439-D2	A439-D2	A439-D2	A439-D2	A439-D2	A439-D2	A439-D2
11	BONNET BOLT	A193-B7	A320-L7	A193-B16	A193-B16	A193-B16	A193-B16	A193-B8
12	BONNET NUT	A194-2H	A194-4	A194-4	A194-4	A194-4	A194-4	A194-8
13	GLAND EYEBOLT	A307B	A307B	193-B7	193-B7	193-B7	193-B7	A193-B8
14	GLAND ADJUSTMENT NUT	A307B	A307B	A194-2H	A194-2H	A194-2H	A194-2H	A194-8
15	GLAND EYEBOLT PIN	C/S 1020	C/S 1020	C/S 1020	C/S 1020	C/S 1020	C/S 1020	A479-304
16	DISC NUT	A479-410	A479-304	A479-410	A479-410	A479-410	A479-410	A479-316
17	HANDWHEEL NUT	A307B	A307B	BA307	A307B	A307B	A307B	A194-8
18	PACKING	Flex. Graphite	Flex. Graphite	Flex. Graphite	Flex. Graphite	Flex. Graphite	Flex. Graphite	Flex. Graphite
19	GASKET	Graphite + 304SS	Graphite + 304SS	Graphite + 304SS	Graphite + 304SS	Graphite + 304SS	Graphite + 304SS	Graphite + 316SS
20	NAMEPLATE	Stainless Steel	Stainless Steel	Stainless Steel	Stainless Steel	Stainless Steel	Stainless Steel	Stainless Steel

- Other materials available on request.
- STL = Stellite #6.

## CAST STEEL GLOBE AND ANGLE VALVE

- Cast steel globe valve, outside screw and yoke
- Bolted bonnet, rising stem, swivel plug disc
- Available in welded and threaded seatings
- Designed according to API-600

Face to Face	ASME/ANSI B16.10
End Flange	ASME/ANSI B16.5
Buttweld	ASME/ANSI B16.25
Rating	ASME/ANSI Class 150

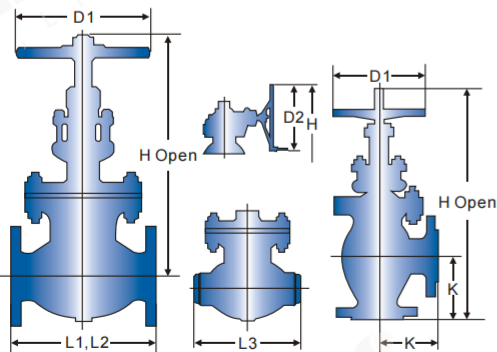

## CLASS 150 DIMENSION

SIZE (in.)	1-1/2"	2"	2-1/2"	3"	4"	6"	8"
L1: RF	6.50	8.00	8.50	9.50	11.50	16.00	19.50
L2: RTJ	7.00	8.50	9.00	10.00	12.00	16.50	20.00
L3: BW	6.50	8.00	8.50	9.50	11.50	16.00	19.50
K: RF/BW	3.25	4.00	4.25	4.75	5.75	8.00	9.75
H	11.42	12.44	12.99	14.37	16.30	19.87	24.53
D1	7.09	2.87	2.87	8.82	11.02	13.98	15.75
D2	-	-	-	-	-	13.98	17.72
W.T R F	38	46	62	75	114	209	371
(lbs) BW	33	36	53	60	90	163	316

SIZE (in.)	10"	12"	14"	16"	18"	20"
L1: RF	24.50	27.50	31.00	36.00	38.50	38.50
L2: RTJ	25.00	28.00	31.50	36.50	39.00	39.00
L3: BW	24.50	27.50	31.00	36.00	38.50	38.50
K: RF/BW	12.25	13.75	15.50	18.00	-	-
H	31.61	33.03	52.99	60.98	70.00	78.98
D1	17.72	19.69	22.05	24.80	31.50	31.50
D2	17.72	19.69	22.05	24.80	27.95	31.50
W.T R F	534	891	1,365	1,808	2,156	2,822
(lbs) BW	426	786	1,234	1,655	1,964	2,597

# Gate, Globe, Check Valve

## CAST STEEL GLOBE AND ANGLE VALVE

- Cast steel globe valve, outside screw and yoke
- Bolted bonnet, rising stem, swivel plug disc
- Available in welded and threaded seatings
- Designed according to API-600

Face to Face	ASME/ANSI B16.10
End Flange	ASME/ANSI B16.5
Buttweld	ASME/ANSI B16.25
Rating	ASME/ANSI Class 300/600

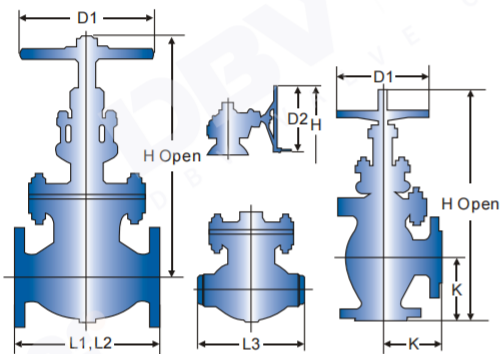

## CAST STEEL GLOBE AND ANGLE VALVE

- Cast steel globe valve, outside screw and yoke
- Bolted bonnet, rising stem, swivel plug disc
- Available in welded and threaded seatings
- Designed according to API-600

Face to Face	ASME/ANSI B16.10
End Flange	ASME/ANSI B16.5
Buttweld	ASME/ANSI B16.25
Rating	ASME/ANSI Class 900/1500

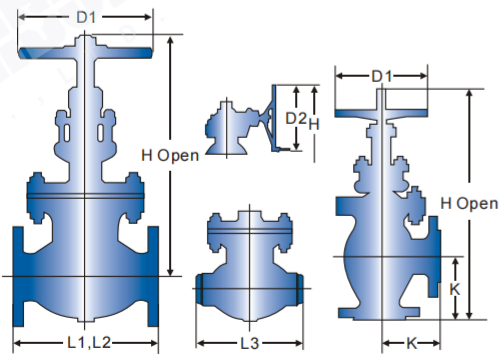

## CLASS 300 DIMENSION

SIZE (in.)	2"	2-1/2"	3"	4"	6"	8"	10"	12"	14"	16"	Unit: inch
L1: R F	10.50	11.50	12.50	14.00	17.50	22.00	24.50	28.00	33.00	34.00	
L2: RTJ	11.13	12.13	13.13	14.63	18.13	22.63	25.13	28.63	33.63	34.63	
L3: BW	10.50	11.50	12.50	14.00	17.50	22.00	24.50	28.00	33.00	34.00	
K: RF/BW	5.25	5.75	6.25	7.00	8.75	11.00	12.25	14.00	-	-	
H	13.78	15.39	16.54	19.37	24.41	31.22	45.08	49.61	55.28	62.99	
D1	7.87	8.82	11.02	13.98	17.72	22.05	22.05	24.80	27.95	27.95	
D2	-	-	-	-	17.72	19.69	22.05	24.80	24.80	27.96	
WT R F	58	88	116	176	370	546	1,005	1,340	2,008	2,650	
(lbs) BW	53	80	94	142	299	440	860	1,143	1,720	2,260	

## CLASS 600 DIMENSION

SIZE (in.)	2"	2-1/2"	3"	4"	6"	8"	10"	12"	Unit: inch
L1: R F	11.50	13.00	14.00	17.00	22.00	26.00	31.00	33.00	
L2: RTJ	11.63	13.13	14.13	17.13	22.13	26.13	31.13	33.13	
L3: BW	11.50	13.00	14.00	17.00	22.00	26.00	31.00	33.00	
K: RF/BW	5.25	5.75	6.25	8.00	9.75	11.75	13.25	15.00	
H	15.43	17.00	18.82	20.87	26.57	28.39	38.27	42.28	
D1	8.82	11.02	12.40	13.98	19.69	22.05	24.80	27.95	
D2	-	-	-	13.98	19.69	22.05	22.05	24.80	
WT R F	82	89	137	253	525	800	1,505	1,984	
(lbs) BW	68	70	109	198	415	637	1,235	1,671	

## CLASS 900 DIMENSION

SIZE (in.)	2"	3"	4"	6"	8"	10"	12"	Unit: inch
L1: R F	14.50	15.00	18.00	24.00	29.00	33.00	38.00	
L2: RTJ	14.63	15.13	18.13	24.13	29.13	33.13	38.13	
L3: BW	14.50	15.00	18.00	24.00	29.00	33.00	38.00	
K: RF/BW	7.25	7.50	9.00	12.00	-	-	-	
H	19.57	20.20	23.74	28.70	38.10	55.40	61.00	
D1	12.40	13.98	15.75	22.05	24.80	27.95	31.50	
D2	-	-	15.75	19.69	22.05	24.80	27.95	
WT R F	215	225	390	920	2,673	4,050	5,247	
(lbs) BW	160	180	330	650	2,370	3,700	4,752	

## CLASS 1500 DIMENSION

SIZE (in.)	2"	3"	4"	6"	8"	10"	12"	Unit: inch
L1: R F	14.50	18.50	21.50	27.75	32.75	39.00	44.50	
L2: RTJ	14.62	18.62	21.62	28.00	33.12	39.38	45.13	
L3: BW	14.50	18.50	21.50	27.75	32.75	39.00	44.50	
K: RF/BW	7.25	8.25	9.25	10.75	13.88	-	-	
H	19.57	23.00	28.10	36.00	46.90	58.00	65.00	
D1	12.40	15.75	15.75	20.00	24.80	28.00	31.50	
D2	-	13.98	15.75	24.80	27.96	31.50	31.50	
WT R F	215	462	772	1,810	4,170	6,330	8,712	
(lbs) BW	160	265	425	1,500	3,540	5,544	7,524	

## TYPICAL DBV CAST STEEL BOLTED COVER SWING CHECK VALVE EXPANDED VIEW

1. Body: DBV cast steel bodies provide low resistance flow and optimum strength and performance.
2. Cover: The cover allows access to internal components.
3. Cover Gasket: The cover gasket creates a leak-proof seal between the bonnet and body.
4. Seat Ring: To ensure a stable shutoff, the seating is aligned and seal-welded into the valve, then precision ground for optimal seating.
5. Disc: The disc allows uni-directional flow and restricts back flow with trouble-free shutoff.
6. Swing Arm: The swing arm allows the disc to open and close.
- 7 & 8. Disc Nut & Pin: The disc nut and pin secure the disc to the swing arm.
9. Hinge Pin: The hinge pin provides a stable mechanism for the swing arm to operate.
10. Plug: The plug secures the arm pin inside the valve.
11. Plug Gasket: The plug gasket creates a leak-proof seal between the plug and body.
- 12 & 13. Cover Studs & Nuts: The cover studs and nuts secure the bonnet to the body.
14. Eyebolt: The eyebolt is used to aid in lifting the valve.

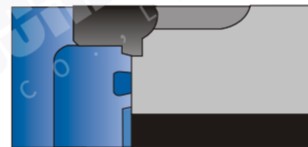
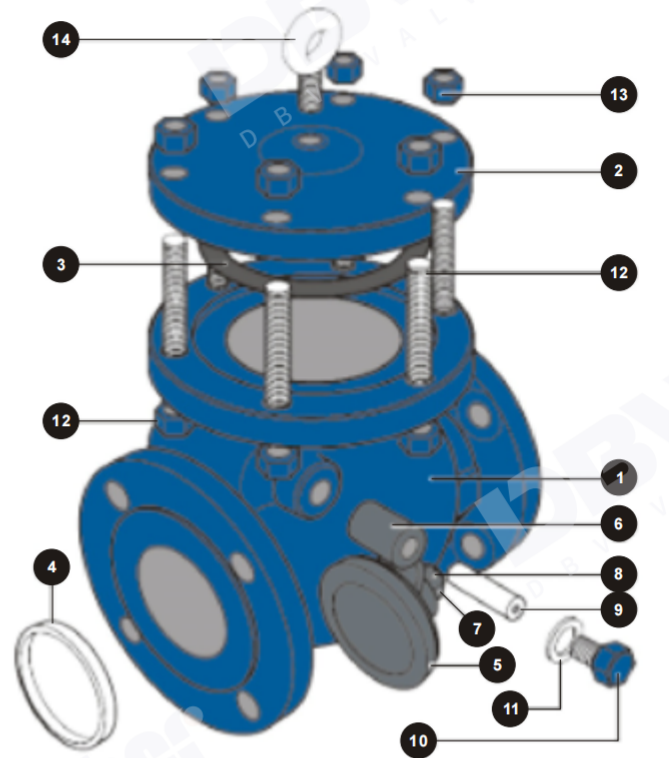

Standard Integral Seat Design seals with a Clapper O-ring.

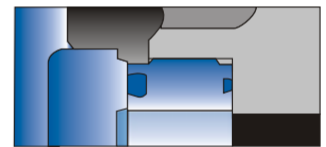

Interchangeable Seat Design extends the service life of the valve.

## CAST STEEL SWING CHECK VALVES STANDARD PARTS AND MATERIALS

NO.	PART NAME	CARBON STEEL			ALLOY STEEL			STAINLESS STEEL
		TYPE WCB	TYPE LCB	TYPE WC6	TYPE WC9	TYPE C5	TYPE C12	TYPE CF8M
1	BODY	A216-WCB	A352-LCB	A217-WC6	A217-WC9	A217-C5	A217-C12	A351-CF8M
2	COVER	A216-WCB	A352-LCB	A217-WC6	A217-WC9	A217-C5	A217-C12	A351-CF8M
3	DISC	A217 CA15 or WCB+410	A351 CF8M or LCB+316	A217 CA15 or WC9+410	A217 CA15 or WC9+410	A217 CA15 or C5+410	A217 CA15 or C12+410	A351-CF8M
4	SEATRING	A105	A182-F316	A182F11+STL	F22+STL	F5a+STL	F9+STL	A479-316
5	HINGEARM	A216-WCB	A352-LCB	A217-WC6	A217-WC9	A217-C5	A217-C12	A351-CF8M
6	DISC NUT	A194 Gr8	A194 Gr8	A194 Gr8	A194 Gr8	A194 Gr8	A194 Gr8	A194-8
7	WASHER	A240-304	A240-316	A240-304	A240-304	A240-304	A240-304	A240-316
8	SPLIT PIN	A580-304	A580-316	A580-304	A580-304	A580-304	A580-304	A580-316
9	COVER BOLT	A193-B7	A320-L7	A193-B16	A193-B16	A193-B16	A193-B16	A193-B8
10	COVER NUT	A194-SH	A194-4	A194-4	A194-4	A194-4	A194-4	A194-8
11	HINGE PIN	A479-410	A479-410	A479-410	A479-410	A479-410	A479-410	A479-316
12	FLANGED PLUG	A479-410	A479-304	A479-304	A479-304	A479-304	A479-304	A479-316
13	GASKET	Graphite + 304SS	Graphite + 304SS	Graphite + 304SS	Graphite + 304SS	Graphite + 304SS	Graphite + 304SS	Graphite + 304SS
14	PLUG GASKET	Soft Steel	Soft Steel	Soft Steel	Soft Steel	Soft Steel	Soft Steel	Stainless Steel
15	NAMEPLATE	Stainless Steel	Stainless Steel	Stainless Steel	Stainless Steel	Stainless Steel	Stainless Steel	Stainless Steel

1. Other materials available on request. 2. STL = Stellite #6.

# Gate, Globe, Check Valve

## CAST STEEL SWING CHECK VALVE

- Cast steel swing checkvalve
- Horizontal or vertical lines, bolted cover
- Available in welded or threaded seat rings
- Designed according to API-600

Face to Face	ASME/ANSI B16.10
End Flange	ASME/ANSI B16.5*
Buttweld	ASME/ANSI B16.25
Rating	ASME/ANSI Class 150

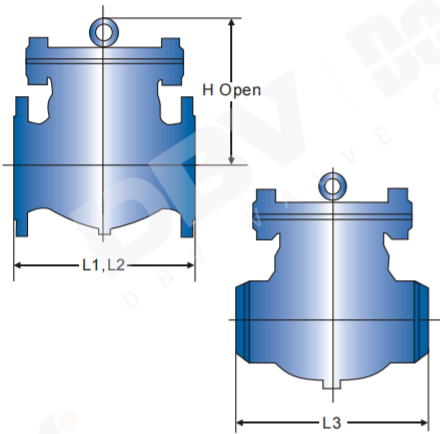

## CAST STEEL SWING CHECK VALVE

- Cast steel swing checkvalve
- Horizontal or vertical lines, bolted cover
- Available in welded or threaded seat rings
- Designed according to API-600

Face to Face	ASME/ANSI B16.10
End Flange	ASME/ANSI B16.5*
Buttweld	ASME/ANSI B16.25
Rating	ASME/ANSI Class 300

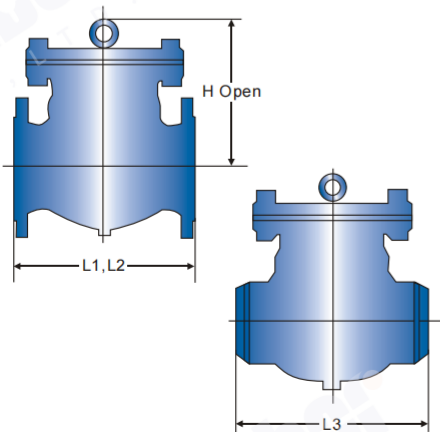

## CLASS 150 DIMENSION

SIZE (in.)	1-1/2"	2"	2-1/2"	3"	4"	6"	8"	10"
Unit: inch								
L1:RF	6.50	8.00	8.50	9.50	11.50	14.00	19.50	24.50
L2:RTJ	7.00	8.50	9.00	10.00	12.00	14.50	20.00	25.00
L3:BW	6.50	8.00	8.50	9.50	11.50	14.00	19.50	24.50
H	5.11	6.30	6.70	7.49	8.87	10.18	12.60	13.72
W.T R F	33	38	48	68	110	203	299	430
(lbs) BW	28	31	38	56	95	183	266	284

SIZE (in.)	12"	14"	16"	18"	20"	24"	30"	36"
Unit: inch								
L1:RF	27.50	31.00	34.00	38.50	38.50	51.00	60.00	77.00
L2:RTJ	28.00	31.50	34.50	39.00	39.00	51.50	60.50	77.50
L3:BW	27.50	31.00	34.00	38.50	38.50	51.00	60.00	77.00
H	14.96	15.79	18.11	19.88	22.20	26.89	36.00	41.50
W.T R F	628	926	1,102	1,411	1,720	3,285	5,077	8,160
(lbs) BW	572	804	980	1,160	1,495	2,945	4,315	7,010

\* 26" and larger are available with ASME/ANSI B16.47 end flanges, either Style A or Style B (formerly MSS SP-44 and API 605).

## CLASS 300 DIMENSION

SIZE (in.)	2"	2-1/2"	3"	4"	6"	8"	10"	12"
Unit: inch								
L1:RF	10.50	11.50	12.50	14.00	17.50	21.00	24.50	28.00
L2:RTJ	11.13	12.13	13.33	14.63	18.13	21.63	25.13	28.63
L3:BW	10.50	11.50	12.50	14.00	17.50	21.00	24.50	28.00
H	6.30	7.44	7.83	8.94	10.94	12.68	15.08	17.13
W.T R F	56	72	108	160	299	406	657	916
(lbs) BW	43	55	88	102	240	317	525	750

SIZE (in.)	14"	16"	18"	20"	24"	30"	36"
Unit: inch							
L1:RF	33.00	34.00	38.50	40.00	53.00	62.75	82.00
L2:RTJ	33.63	34.63	39.13	40.75	53.88	63.75	83.00
L3:BW	33.00	34.00	38.50	40.00	53.00	62.75	82.00
H	20.08	20.51	22.52	24.76	28.03	37.00	42.99
W.T R F	1,503	1,649	2,097	2,494	4,500	5,850	10,500
(lbs) BW	1,241	1,305	1,803	2,150	3,870	5,020	9,450

\* 26" and larger are available with ASME/ANSI B16.47 end flanges, either Style A or Style B (formerly MSS SP-44 and API 605).

## CAST STEEL SWING CHECK VALVE

- Cast steel swing checkvalve
- Horizontal or vertical lines, bolted cover
- Available in welded or threaded seat rings
- Designed according to API-600

Face to Face	ASME/ANSI B16.10
End Flange	ASME/ANSI B16.5
Buttweld	ASME/ANSI B16.25
Rating	ASME/ANSI Class 600~1500

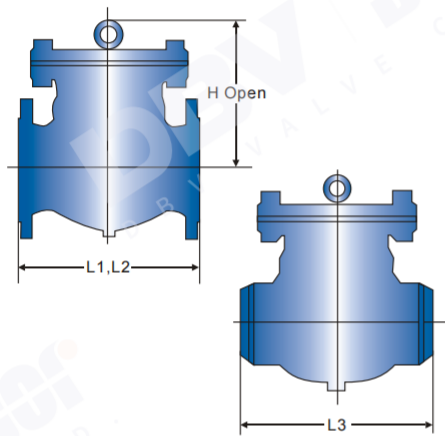

## TILTING DISC CHECK VALVE

- Cast Steel Tilting Disc Check Valve
- Bolted Cover, Horizontal Lines
- Designed to ASME B16.34, API 6D

Face to Face	ASME/ANSI B16.10
End Flange	ASME/ANSI B16.5
Buttweld	ASME/ANSI B16.25
Class	ASME/ANSI CL150/300/600

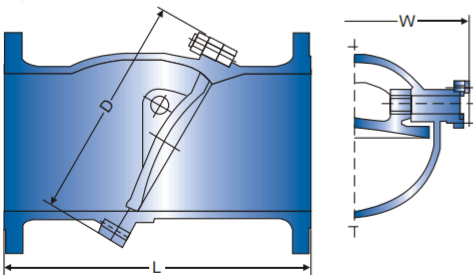

## CLASS 600 DIMENSION

SIZE (in.)	2"	3"	4"	6"	8"	10"	12"	14"	16"	18"	20"	24"
L1:RF	11.50	14.00	17.00	22.00	26.00	31.00	33.00	35.00	39.00	43.00	47.00	55.00
L2:RTJ	11.63	14.13	17.13	22.13	26.13	31.13	33.13	35.13	39.13	43.13	47.25	55.38
L3:BW	11.50	14.00	17.00	22.00	26.00	31.00	33.00	35.00	39.00	43.00	47.00	55.00
H	7.38	8.25	10.06	12.94	14.31	18.25	19.13	22.50	26.00	28.00	31.00	34.00
WT R F	71	130	247	474	849	1,351	1,918	2,068	2,976	4,451	5,269	6,634
(lbs) BW	66	110	223	364	686	1,081	1,605	1,693	2,469	3,802	4,443	5,137

## CLASS 900 DIMENSION

SIZE (in.)	2"	3"	4"	6"	8"	10"	12"	14"	16"	18"	20"	24"
L1:RF	14.50	15.00	18.00	24.00	29.00	33.00	38.00	40.50	44.50	48.00	52.00	61.00
L2:RTJ	14.63	15.13	18.13	24.13	29.13	33.13	38.13	40.87	44.87	48.50	52.50	61.75
L3:BW	14.50	15.00	18.00	24.00	29.00	33.00	38.00	40.50	44.50	48.00	52.00	61.00
H	10.51	11.42	12.05	13.31	18.11	19.69	22.75	25.47	27.95	30.90	33.46	36.61
WT R F	161	181	307	582	1,210	1,800	3,200	3,850	5,324	7,150	8,800	12,760
(lbs) BW	119	136	235	247	1,010	1,545	2,720	3,190	4,510	5,940	7,260	9,900

## CLASS 1500 DIMENSION

SIZE (in.)	2"	3"	4"	6"	8"	10"	12"	14"	16"	18"	20"	24"
L1:RF	14.50	18.50	21.50	27.75	32.75	39.00	44.50	49.50	54.50	60.50	65.50	76.50
L2:RTJ	14.63	18.63	21.63	28.00	33.13	39.37	45.12	50.25	55.37	61.37	66.37	77.63
L3:BW	14.50	18.50	21.50	27.75	32.75	39.00	44.50	49.50	54.50	60.50	65.50	76.50
H	10.51	11.65	13.98	18.31	21.26	22.64	26.38	28.54	31.89	35.63	39.57	44.27
WT R F	161	276	467	1,067	2,356	3,663	5,445	7,128	9,700	13,060	16,130	23,265
(lbs) BW	119	209	362	813	1,910	2,930	4,310	5,600	7,720	10,395	12,770	17,820

## CLASS 150 DIMENSION

SIZE (in.)	2"	2-1/2"	3"	4"	6"	8"	10"	12"	14"	16"	18"	20"	24"	26"	28"	30"	32"
L	203	216	241	292	356	495	622	698	787	864	978	1295	1295	1143	1143	1194	
D	160	182	196	230	300	390	432	510	540	635	700	770	900	930	991	1020	1150
W	178	198	224	252	326	426	456	530	576	670	740	818	948	988	1050	1090	1240
W.T(kg)	11	16	22	34	62	112	169	238	337	420	550	685	910	1055	1260	1540	1860

## CLASS 300 DIMENSION

SIZE (in.)	2"	2-1/2"	3"	4"	6"	8"	10"	12"	14"	16"	18"	20"	24"	26"	28"	30"	32"
L	267	292	318	356	444	533	622	711	838	864	978	1016	1346	1346	1295	1372	1448
D	170	196	214	245	320	400	460	540	580	660	725	800	940	970	1040	1080	1210
W	198	220	232	268	360	426	457	572	620	690	760	848	988	1018	1250	1280	1350
W.T(kg)	17	22	32	97	110	162	228	380	443	530	780	980	1320	1364	1762	2050	2870

## CLASS 600 DIMENSION

SIZE (in.)	2"	2-1/2"	3"	4"	6"	8"	10"	12"	14"	16"	18"	20"	24"
L	292	330	356	432	559	660	787	838	889	991	1092	1194	1397
D	185	196	210	270	340	440	520	570	610	690	755	850	990
W	212	225	240	298	405	460	492	602	650	710	780	902	1040
W.T(kg)	27	44	47	115	190	320	430	586	750	1015	1480	2050	2550

# Gate, Globe, Check Valve

## PISTON CHECK VALVE

- Cast Steel Check Valve, Lift Piston
- Bolted Cover, Horizontal or Vertical Lines
- Integral or Removable Seat, Metal to Metal
- Designed to ASME B16.34, API 6D

Face to Face	ASME/ANSI B16.10
End Flange	ASME/ANSI B16.5
Buttweld	ASME/ANSI B16.25
Class	ASME/ANSI CL150~CL900

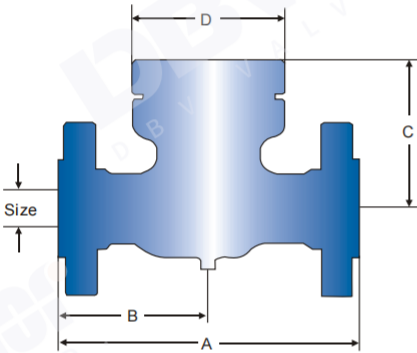

### CLASS 150 DIMENSION

SIZE (in.)	2"	3"	4"	6"	8"	10"	12"
Unit: inch							
A RF	10.50	12.50	14.00	17.50	19.50	24.50	27.50
RTJ	11.13	13.13	14.63	18.13	20.00	25.00	28.00
B RF	5.25	6.25	7.00	8.75	9.75	12.25	13.75
RTJ	5.56	6.56	7.31	9.06	10.00	12.50	14.00
C	6.50	8.00	11.25	16.13	16.75	18.50	22.50
D	7.00	8.25	9.75	11.75	14.50	17.00	24.00

### CLASS 300 DIMENSION

SIZE (in.)	2"	3"	4"	6"	8"	10"	12"
Unit: inch							
A RF	10.50	12.50	14.00	17.50	21.00	24.50	28.00
RTJ	11.13	13.13	14.63	18.13	21.63	25.13	28.63
B RF	5.25	6.25	7.00	8.75	10.50	12.25	14.00
RTJ	5.56	6.56	7.31	9.06	10.81	12.56	14.31
C	6.50	8.00	11.25	16.13	16.75	18.50	22.50
D	7.00	8.25	9.75	11.75	14.50	17.00	24.00

### CLASS 600 DIMENSION

SIZE (in.)	2"	3"	4"	6"	8"	10"	12"
Unit: inch							
A RF	11.50	14.00	17.00	22.00	26.00	31.00	33.00
RTJ	11.63	14.13	17.13	22.13	26.13	31.13	33.13
B RF	5.75	7.00	8.50	11.00	13.00	15.50	16.50
RTJ	5.56	7.06	8.56	11.06	13.06	15.56	16.56
C	6.75	8.25	11.50	16.38	16.75	18.50	22.50
D	7.00	8.25	9.75	11.75	14.50	17.00	24.00

### CLASS 900 DIMENSION

SIZE (in.)	2"	3"	4"	6"	8"	10"	12"
Unit: inch							
A RF	14.50	15.00	18.00	24.00	29.00	33.00	38.00
RTJ	14.63	15.13	18.13	24.13	29.13	33.13	38.13
B RF	7.25	7.50	9.00	12.00	14.50	16.50	19.00
RTJ	7.31	7.56	9.06	12.06	14.56	16.56	19.06
C	7.00	8.50	11.88	16.75	16.75	18.50	22.50
D	7.00	8.25	9.75	11.75	14.50	17.00	24.00

## PRESSURE LOSS CURVES FOR PISTON CHECK VALVES • FLOW RATE (GALLONS WATER PER MINUTE)

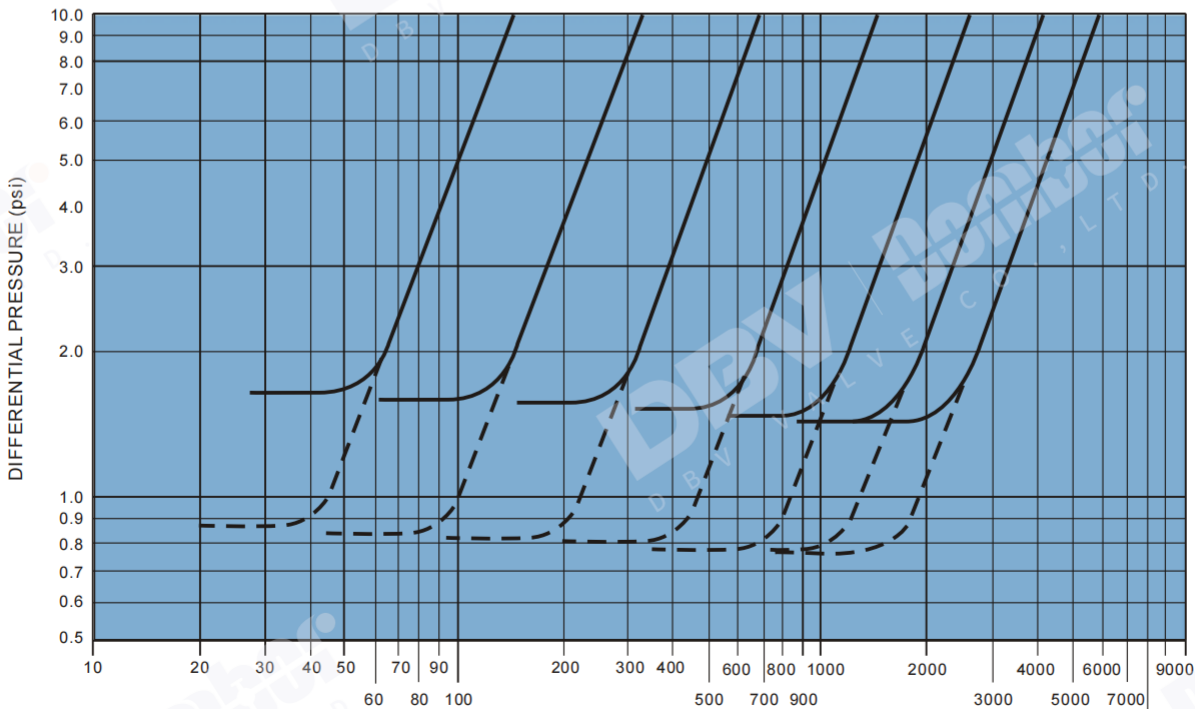

DOTTED LINES REPRESENT PRESSURE LOSS FOR VALVES WITHOUT SPRINGS

8000

DBV VALVE CO., LTD.

**NON SLAM CHECK VALVE CHARACTERISTICS**

**FEATURES**

Extensive research and development, coupled with valid design procedures, have resulted in these unique non slam check features:

Few moving parts—Disc is the only moving part, minimizing wear.

Axial movement of disc—Disc and seating configuration give streamlined flow path with venturi effect, resulting in low pressure drop.

Short stroke of spring-assisted disc—Inlet flow velocity moves disc axially with short stroke. In response to flow velocity reduction, a compressed spring initiates valve closure and provides quick response.

Spring options—Choice of spring affects critical velocity and valve response. Selection is made on engineering evaluation of specific applications. In absence of this data, a standard spring will be provided.

**CHARACTERISTICS**

Non slam check valves deliver an effective dynamic response under various flow deceleration conditions. The dynamic performance characteristics of non slam check valve are compared to swing check and dual plate spring-assisted check valves in Figure 1.

Non slam check valve's unique design features result in superior performance, fast response and lower pressure loss in piping systems.

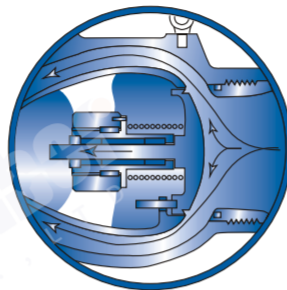

**OPENING**

Reduced pressure, generated by increased velocity in the minimal flow area results in additional force to assist the disc to open and allows for extra spring loading that facilitates a faster closing time.

This spring force is balanced in the fully open position. The Non slam check geometry is established by considering the design velocity required to ensure that the disc is stabilized open against its stop even if moderate flow oscillation occurs.

**CLOSING**

When a noticeable reduction in flow occurs, the disc reacts immediately, limiting backflow and valve slamming:

The spring load, low mass disc, and short displacement ensures a rapid self-dampening response.

For certain applications, the internal geometry can be modified to suit the service conditions.

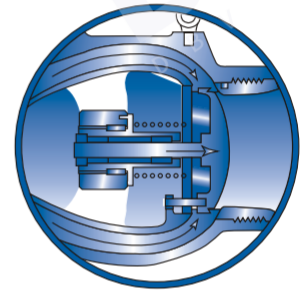
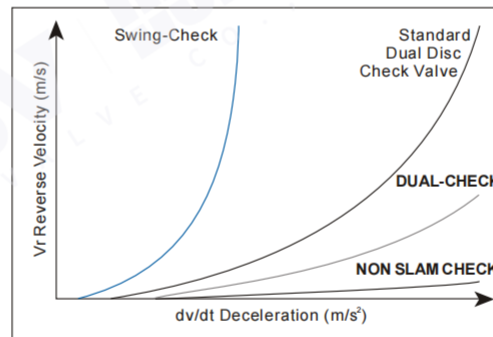

Figure 1



**STANDARD MATERIALS OF CONSTRUCTION**

Part Name	Standard Carbon Steel	Low Temperature Carbon Steel	Stainless Steel
Valve Body	ASTMA216 WCB	ASTMA352 LCC	ASTMA351 CF8M / 316 Stainless Steel
Diffuser	ASTMA216 WCB	ASTMA352 LCC	ASTMA351 CF8M / 316 Stainless Steel
Valve Disc	ASTMA351 CF8M / 316 Stainless Steel	ASTMA351 CF8M / 316 Stainless Steel	ASTMA351 CF8M / 316 Stainless Steel
Seat	Alloy 625	Alloy 625	Alloy 625
Helical Spring	Alloy X-750	Alloy X-750	Alloy X-750
Radial Guide	Alloy X-750	Alloy X-750	Alloy X-750
Screw	ASTMA193 B8M	ASTMA320 B8M	ASTMA193 B8M
Central Tie Bolt	ASTMA193 B7M	ASTMA320 L7M	ASTMA193 B8M
Guide Bushing	Gr. 630 Stainless Steel	Gr. 630 Stainless Steel	-

Other materials available upon request to meet specific service requirements.



# Gate, Globe, Check Valve

## NON SLAM CHECK VALVE

- Cast Steel Check Valve, Axial Flow
- Uni-body, Horizontal or Vertical Lines
- Spring-assisted slow closing, Watertight Seating
- Designed to ASME B16.34, API 6D

Face to Face	ASME/ANSI B16.10
End Flange	ASME/ANSI B16.5
Buttweld	ASME/ANSI B16.25
Class	ASME/ANSI CL150~CL2500

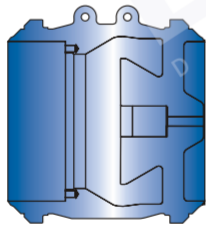
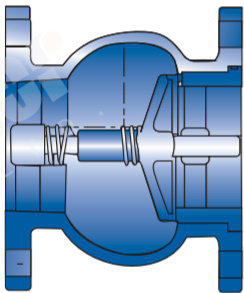
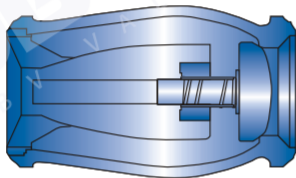
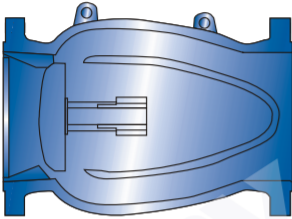

### CLASS 150 DIMENSION

DBV Standard SIZE (IN)	DBV Standard			API 6D Standard			Unit: mm
	R.T.	J.R.F	W.E	R.T.	R.F	W.E	
2	-	-	-	216	203	203	
3	-	-	-	254	241	241	
4	-	-	-	305	292	292	
6	266	253	265	368	356	356	
8	308	295	305	508	495	495	
10	378	365	380	635	622	622	
12	448	435	450	711	698	698	
14	488	475	490	800	787	787	
16	558	545	560	876	864	864	
18	623	610	630	991	978	978	
20	688	675	700	991	978	978	
24	823	810	835	1308	1295	1295	
28	-	549	579	-	8441	8441	
30	-	101	5401	-	4251	4251	
32	-	1080	1115	-	-	-	
36	-	1215	1250	-	1956	1956	
40	-	1350	1390	-	-	-	
42	-	1415	1460	-	-	-	
48	-	1615	1650	-	-	-	

### CLASS 300 DIMENSION

DBV Standard SIZE (IN)	DBV Standard			API 6D Standard			Unit: mm
	R.T.	J.R.F	W.E	R.T.	R.F	W.E	
2	-	-	-	283	267	267	
3	-	-	-	333	317	317	
4	-	-	-	371	356	356	
6	269	253	265	460	444	444	
8	311	295	305	549	533	533	
10	381	365	380	638	622	622	
12	451	435	450	727	711	711	
14	491	475	490	854	838	838	
16	561	545	560	879	864	864	
18	626	610	630	994	978	978	
20	694	675	700	1035	1016	1016	
24	832	810	835	1368	1346	1346	
28	970	945	975	1524	1499	1499	
30	1035	1010	1045	1619	1594	1594	
32	1109	1080	1115	-	-	-	
36	1244	1215	1250	2112	2083	2083	
40	-	1350	1390	-	-	-	
42	-	1415	1460	-	-	-	
48	-	1615	1650	-	-	-	

### CLASS 400 DIMENSION

DBV Standard SIZE (IN)	DBV Standard			API 6D Standard			Unit: mm
	R.T.	J.R.F	W.E	R.T.	R.F	W.E	
2	-	-	-	295	292	292	
3	-	-	-	359	356	356	
4	-	-	-	409	406	406	
6	256	253	265	498	495	495	
8	298	295	305	600	597	597	
10	368	365	380	676	673	673	
12	438	435	450	765	762	762	
14	478	475	490	892	889	889	
16	548	545	560	905	902	902	
18	613	610	630	1019	1016	1016	
20	681	675	700	1060	1054	1054	
24	819	810	835	1407	1397	1397	
28	958	945	975	1613	1600	1600	
30	1023	1010	1045	1664	1651	1651	
32	1096	1080	1115	-	-	-	
36	1231	1215	1250	2099	2083	2083	
40	-	1350	1390	-	-	-	
42	-	1415	1460	-	-	-	
48	-	1615	1650	-	-	-	

### CLASS 600 DIMENSION

DBV Standard SIZE (IN)	DBV Standard			API 6D Standard			Unit: mm
	R.T.	J.R.F	W.E	R.T.	R.F	W.E	
2	-	-	-	295	292	292	
3	-	-	-	359	356	356	
4	-	-	-	435	432	432	
6	256	253	265	562	559	559	
8	298	295	305	664	660	660	
10	368	365	380	791	787	787	
12	438	435	450	841	838	838	
14	478	475	490	892	889	889	
16	548	545	560	994	991	991	
18	613	610	630	1095	1092	1092	
20	681	675	700	1200	1194	1194	
24	819	810	835	1407	1397	1397	
28	958	945	975	1613	1600	1600	
30	1023	1010	1045	1664	1651	1651	
32	1096	1080	1115	-	-	-	
36	1231	1215	1250	2099	2083	2083	
40	-	1350	1390	-	-	-	
42	-	1415	1460	-	-	-	
48	-	1615	1650	-	-	-	

### CLASS 2500 DIMENSION

DBV Standard SIZE (IN)	DBV Standard			API 6D Standard			Unit: mm
	R.T.	J.R.F	W.E	R.T.	R.F	W.E	
2	-	-	-	454	451	451	
3	-	-	-	584	578	578	
4	304	295	253	683	673	673	
6	403	390	324	927	914	914	
8	446	430	367	1038	1022	1022	
10	562	540	424	1292	1270	1270	
12	617	595	486	1445	1422	1422	

### CLASS 900 DIMENSION

DBV Standard SIZE (IN)	DBV Standard			API 6D Standard			Unit: mm
	R.T.	J.R.F	W.E	R.T.	R.F	W.E	
2	-	-	-	371	368	368	
3	-	-	-	384	381	381	
4	238	235	238	460	457	457	
6	306	303	306	613	610	610	
8	344	341	344	740	737	737	
10	394	391	394	841	838	838	
12	451	448	451	968	965	965	
14	494	485	494	1038	1029	1029	
16	610	558	610	1140	1130	1130	
18	632	619	632	1232	1219	1219	
20	697	684	697	1334	1321	1321	
24	838	819	838	1568	1549	1549	

### CLASS 1500 DIMENSION

DBV Standard SIZE (IN)	DBV Standard			API 6D Standard			Unit: mm
	R.T.	J.R.F	W.E	R.T.	R.F	W.E	
2	-	-	-	371	368	368	
3	-	-	-	473	470	470	
4	238	235	238	549	546	546	
6	306	300	306	711	705	705	
8	344	335	344	841	832	832	
10	394	385	394	1000	991	991	
12	451	435	451	1146	1130	1130	
14	494	475	494	1276	1257	1257	
16	567	545	567	1407	1384	1384	
18	632	610	632	1559	1537	1537	
20	697	675	697	1686	1664	1664	
24	838	810	838	1972	1943	1943	

DBV DUAL PLATE CHECK VALVE DESIGN FEATURES

LAPPED BODY & DISC SEATS

The heart of each valve is the seat/seal interface. Our valves are manufactured using the most updated machining methods and equipment to achieve maximum flatness with a fine lapped finish. The end result is valves that easily meet and exceed test requirements of API 598 for metal-seated check valves.

INTRINSICALLY FIRE SAFE

With no drilling through the body wall, the Proquip dual plate check valve is intrinsically fire safe.

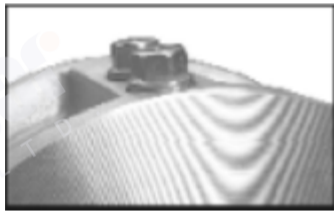

Common dual plate check valves

Conventional dual plate check valves require holes through the body wall to facilitate the installation of the hinge and stoppins. These holes are sealed by threaded pipe plugs called retainers. After being in service for a period of time, these plugs often leak due to temperature cycling, vibration and other causes.

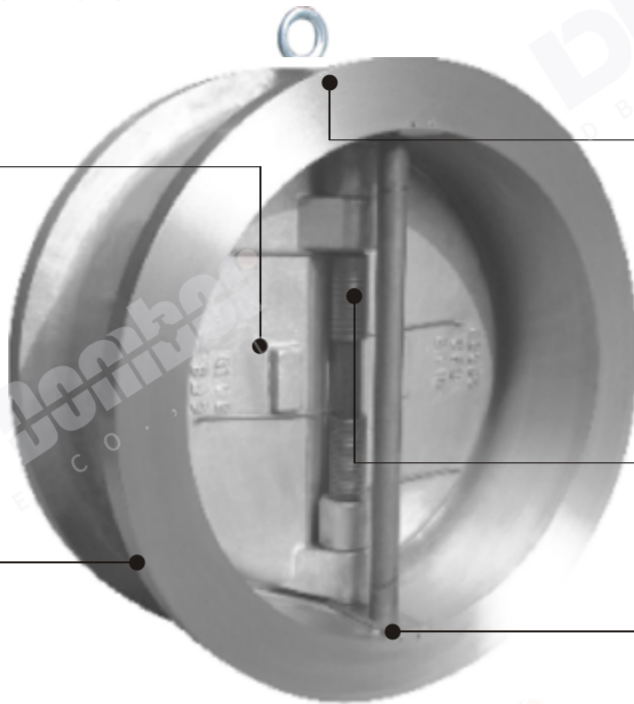

RETAINERLESS BODY DESIGN

The Proquip dual plate check valve's body is essentially a short, heavy wall cylinder with no holes through the body wall. There is no need for retainers and leakage to the outside is impossible.

HIGH TORSION SPRING

For potentially severe applications, a high torsion spring ensures the valve closes as quickly as possible.

SUPERIOR HINGE DESIGN

In order to eliminate seat wear during the opening cycle, all dual plate check valves incorporate clearance between the hinge pin and holders, or hinge pin and disc bore. This clearance allows the disc assembly to lift off the seat prior to disc rotation preventing the heel of each disc from scraping across the body seat. Conventional designs have an oversize bore in the discs or bearings, allowing constant side to side movement of discs and increased chance of premature failure.

DBV WAFER CHECK VALVES MAIN PARTS MATERIALS

CARBON STEEL

BODY	DISC	BODY SEAT	DISC SEAT	SPRING	WETTED PARTS
A216 Gr. WCB	A351 Gr. CF8M	Same as Body	Same as Disc	Inconel X-750	316 SS
A216 Gr. WCB	A351 Gr. CF8M	Viton	Same as Disc	Inconel X-750	316 SS
A216 Gr. WCB	A351 Gr. CF8M	Stellite overlay	Same as Disc	Inconel X-750	316 SS
A216 Gr. WCB	A217 Gr. CA15	410 SS overlay	Same as Disc	Inconel X-750	410 SS
A216 Gr. WCB	A217 Gr. CA15	Stellite overlay	Same as Disc	Inconel X-750	410 SS

LOW TEMPERATURE CARBON STEEL

BODY	DISC	BODY SEAT	DISC SEAT	SPRING	WETTED PARTS
A352 Gr. LCC	A351 Gr. CF8M	Same as Body	Same as Disc	Inconel X-750	316 SS
A352 Gr. LCC	A351 Gr. CF8M	Buna-N	Same as Disc	Inconel X-750	316 SS
A352 Gr. LCC	A351 Gr. CF8M	Stellite overlay	Same as Disc	Inconel X-750	316 SS

STAINLESS STEEL

BODY	DISC	BODY SEAT	DISC SEAT	SPRING	WETTED PARTS
A351 Gr. CF8M	A351 Gr. CF8M	Same as Body	Same as Disc	Inconel X-750	316 SS
A351 Gr. CF8M	A351 Gr. CF8M	Viton	Same as Disc	Inconel X-750	316 SS
A351 Gr. CF8M	A351 Gr. CF8M	Stellite overlay	Same as Disc	Inconel X-750	316 SS

Other Materials Available Upon Request

# Gate, Globe, Check Valve

## DUAL PLATE WAFER CHECK VALVE FLOW VOLUME VS PRESSURE DROP

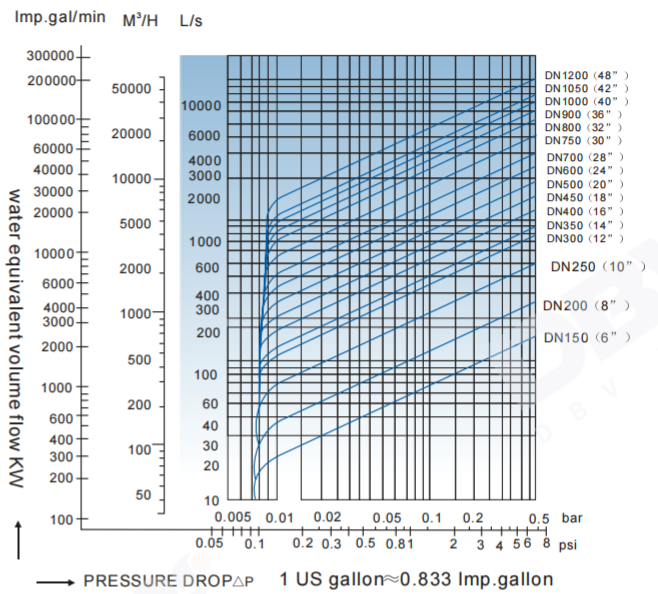
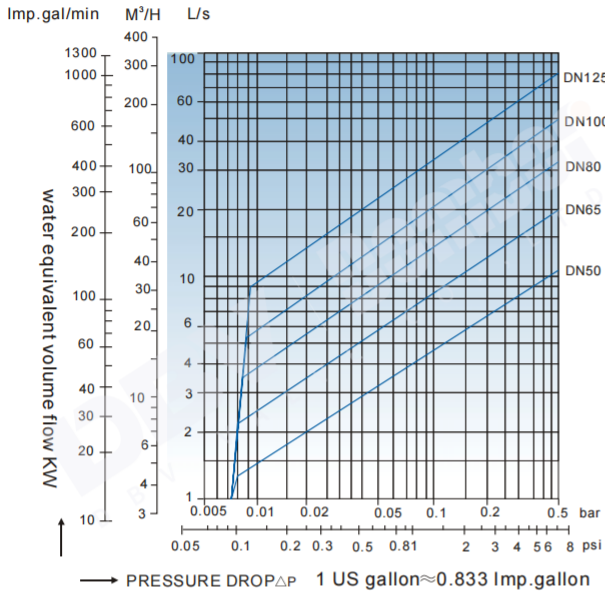

## DUAL PLATE WAFER CHECK VALVE FRICTION FACTOR FLOW COEFFICIENCY

SIZE (in.)	Friction Factor Under Valve Full OPEN $\xi$		Flow Coefficiency Under Standard Temp.		Flow Direction	
	Cv	Kv	Cv(U.S)	Cv(U.k)	↑ Approx. Open Pressure KPa	→
2	2.6	63	74	62	2	1
2-1/2	2.4	109	128	107	2	1
3	2.3	172	201	169	2	1
4	2.0	289	338	283	2	1
5	1.8	476	557	466	2	1
6	1.5	750	878	735	2	1
8	1.3	1432	1675	1403	2	1
10	1.2	2330	2726	2283	2	1
12	1.0	3676	4301	3602	2	1
14	0.9	5274	6171	5169	2	1
16	0.8	7306	8548	7160	3	1
18	0.8	9246	10818	9061	3	1
20	0.8	11415	13356	11187	3	1
24	0.7	17573	20560	17222	3	1
28	0.7	23919	27985	23441	4	1
30	0.7	27458	32126	26909	4	1
32	0.7	31241	36552	30616	4	1
36	0.7	39539	46261	38748	4	1
40	0.7	48814	57112	47838	4	1
42	0.7	53817	62966	52741	4	1
48	0.7	70292	82242	68886	4	1

## WAFER DUAL PLATE CHECK VALVE

- Cast Steel Check Valve, Wafer Ends, Dual Plates
- Spring Loaded, Horizontal or Vertical Lines
- Designed to API594, API6D

Face to Face	API594/API 6D
Wall Thickness	ASME B16.34
End Flange	NPS2~24: ASME B16.5*
Class	ASME/ANSI CL150

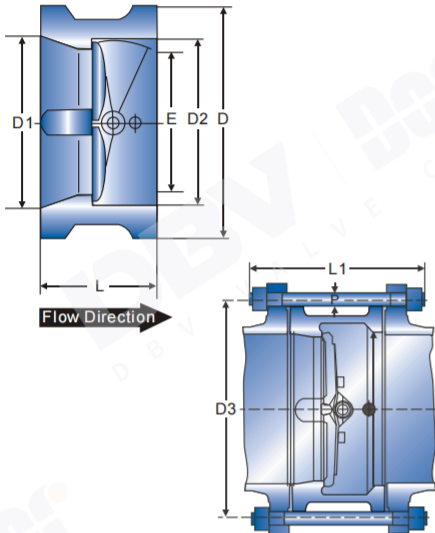

## CLASS 150 DIMENSION

SIZE (in.)	L	D	D1	D2	W.T (kg)	D3	STUD/BOLTING DETAILS				
							NO.	DIA. in mm	LENGTH RF RTJ		
1-1/2	60	83	38	45	2	98.5	4	1/2	M14	130	145
2	60	103	51	56	2	120.5	4	5/8	M16	140	155
2-1/2	67	122	65	73	3	139.5	4	5/8	M16	150	165
3	73	135	80	88	4	152.5	4	5/8	M16	160	175
4	73	173	102	108	6	190.5	8	5/8	M16	170	185
5	86	195	127	132	8	216.0	8	3/4	M20	190	205
6	98	220	152	160	12	241.5	8	3/4	M20	205	220
8	127	277	203	210	25	298.5	8	3/4	M20	240	255
10	146	337	254	266	38	362.0	12	7/8	M24	270	285
12	181	407	305	310	52	432.0	12	7/8	M24	310	325
14	184	448	350	355	80	476.0	12	1	M27	325	340
16	191	512	400	405	115	540.0	16	1	M27	340	355
18	203	547	450	455	138	578.0	16	1-1/8	M30	365	380
20	219	604	500	505	162	635.0	20	1-1/8	M30	385	400
24	222	715	600	605	330	749.5	20	1-1/4	M33	405	420
26	222	722	633	650	360	744.5	36	3/4	M20	365	-
28	305	773	700	700	380	795.5	40	3/4	M20	455	-
30	305	824	746	750	420	846.0	44	3/4	M20	455	-
32	305	878	796	800	260	900.0	48	3/4	M20	460	-
36	368	983	874	894	630	1009.5	44	7/8	M24	540	-
40	432	1090	976	985	870	1120.5	44	1	M27	620	-
42	432	1142	1050	1055	960	1171.5	48	1	M27	625	-
44	432	1193	1070	1070	1140	1222	52	1	M27	630	-
48	524	1302	1200	1205	1400	1335.0	44	1-1/8	M30	740	-
54	591	1460	1312	1315	2240	1492	44	1-1/8	M30	820	-
56	591	1512	1360	1370	2830	1543	60	1-1/8	M30	820	-
60	660	1628	1458	1470	3200	1662	52	1-1/4	M33	900	-

\* 26" and larger are available with ASME/ANSI B16.47 end flanges, either Style A or Style B (formerly MSS SP-44 and API 605).

## WAFER DUAL PLATE CHECK VALVE

- Cast Steel Check Valve, Wafer Ends, Dual Plates
- Spring Loaded, Horizontal or Vertical Lines
- Designed to API594, API6D

Face to Face	API594/API 6D
Wall Thickness	ASME B16.34
End Flange	NPS2~24: ASME B16.5*
Class	ASME/ANSI CL300

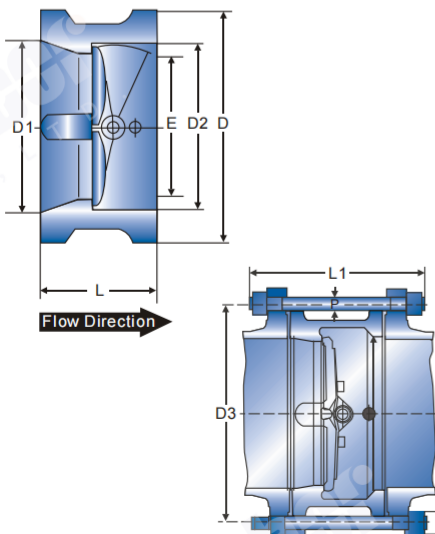

## CLASS 300 DIMENSION

SIZE (in.)	L	D	D1	D2	W.T (kg)	D3	STUD/BOLTING DETAILS				
							NO.	DIA. in mm	LENGTH RF RTJ		
2	60	110	51	58	3	127.0	8	5/8	M16	155	175
2-1/2	67	128	65	73	4	149.0	8	3/4	M20	175	195
3	73	147	80	88	6	168.5	8	3/4	M20	190	210
4	73	179	102	108	8	200.0	8	3/4	M20	195	215
5	86	214	127	132	12	235.0	8	3/4	M20	215	235
6	98	249	152	160	18	270.0	12	3/4	M20	230	250
8	127	305	203	210	30	330.0	12	7/8	M24	280	300
10	146	359	254	266	50	387.5	16	1	M27	315	335
12	181	420	305	310	75	451.0	16	1-1/8	M30	365	385
14	222	483	350	355	115	514.5	20	1-1/8	M30	410	430
16	232	537	400	405	190	571.5	20	1-1/4	M33	435	455
18	264	594	450	455	200	628.5	24	1-1/4	M33	475	495
20	292	652	500	505	260	686.0	24	1-1/4	M33	510	535
24	318	772	600	608	410	813.0	24	1-1/2	M39x3	560	585
26	356	767	633	640	560	803	32	1-1/4	M33	625	-
28	368	821	685	685	580	857	36	1-1/4	M33	635	-
30	368	882	735	740	660	921.0	36	1-3/8	M39x3	650	-
32	368	936	784	784	970	978	32	1-1/2	M39x3	675	-
36	483	1044	873	880	1010	1089.0	32	1-5/8	M42x3	800	-
40	546	1146	976	985	1420	1191	40	1-5/8	M42x3	885	-
42	568	1196	1035	1045	1540	1244.5	36	1-3/4	M45x3	920	-
48	629	1365	1166	1190	2250	1416.0	40	1-7/8	M48x3	1010	-
54	718	1526	1312	1315	3100	1578	48	1-7/8	M48x3	1140	-
60	838	1704	1458	1470	4310	1764	40	2-1/4	M56x3	1280	-

\* 26" and larger are available with ASME/ANSI B16.47 end flanges, either Style A or Style B (formerly MSS SP-44 and API 605).

# Gate, Globe, Check Valve

## WAFER DUAL PLATE CHECK VALVE

- Cast Steel Check Valve, Wafer Ends, Dual Plates
- Spring Loaded, Horizontal or Vertical Lines
- Designed to API594, API6D

Face to Face	API594/API 6D
Wall Thickness	ASME B16.34
End Flange	NPS2~24: ASME B16.5*
Class	ASME/ANSI CL600/900

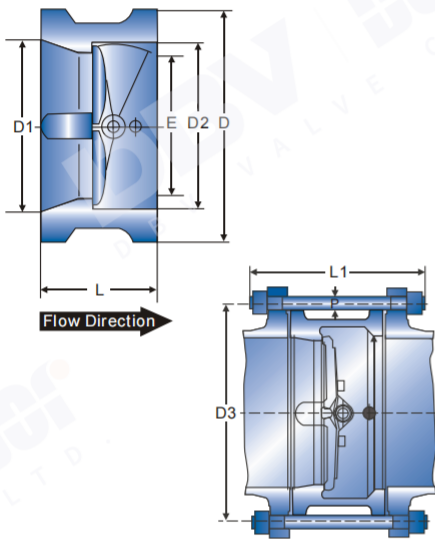

## CLASS 600 DIMENSION

SIZE (in.)	L	D	D1	D2	W.T (kg)	D3	STUD/BOLTING DETAILS				
							NO.	DIA. in	DIA. mm	LENGTH RF RTJ	
2	60	110	51	58	4	127.0	8	5/8	M16	175	180
2-1/2	67	128	65	73	5	149.0	8	3/4	M20	195	200
3	73	147	80	88	8	168.5	8	3/4	M20	210	215
4	79	191	102	108	11	216.0	8	7/8+	M24	235	240
5	105	239	127	136	20	267.0	8	1	M27	280	285
6	136	264	152	162	25	292.0	12	1	M27	320	325
8	165	318	200	212	50	349.0	12	1-1/8	M30	370	375
10	213	398	250	266	90	432.0	16	1-1/4	M33	440	445
12	229	455	305	312	140	489.0	20	1-1/4	M33	460	465
14	273	490	337	355	220	527.0	20	1-3/8	M36x3	520	525
16	305	562	387	400	360	603.0	20	1-1/2	M39x3	575	580
18	362	610	438	450	380	654.0	20	1-5/8	M42x3	650	655
20	368	680	489	500	510	724.0	24	1-5/8	M42x3	670	680
24	438	786	591	600	830	838.0	24	1-7/8	M48x3	780	795

## CLASS 900 DIMENSION

SIZE (in.)	L	D	D1	D2	W.T (kg)	D3	STUD/BOLTING DETAILS				
							NO.	DIA. in	DIA. mm	LENGTH RF RTJ	
2	70	140	51	58	8	165.0	8	7/8	M24	225	230
2-1/2	83	162	65	73	10	190.5	8	1	M27	250	255
3	83	165	80	90	14	190.5	8	7/8	M24	240	245
4	102	204	102	108	20	235.0	8	1-1/8	M30	285	290
5	110	245	127	136	30	279.5	8	1-1/4	M33	310	315
6	159	286	150	162	40	317.5	12	1-1/8	M30	365	370
8	206	356	200	212	80	393.5	12	1-3/8	M36x3	440	445
10	241	432	250	266	140	470.0	16	1-3/8	M36x3	490	495
12	292	495	305	312	220	533.5	20	1-3/8	M36x3	560	565
14	356	518	337	355	350	559.0	20	1-1/2	M39x3	645	655
16	384	572	387	400	470	616.0	20	1-5/8	M42x3	685	695
18	451	635	438	450	600	686.0	20	1-7/8	M48x3	790	805
20	451	695	487	496	820	749.5	20	2	M52x3	810	825
24	495	835	591	600	1050	901.5	20	2-1/2	M64x3	945	965

\*26" and larger are available with ASME/ANSI B16.47 end flanges, either Style A or Style B (formerly MSS SP-44 and API 605).

## WAFER DUAL PLATE CHECK VALVE

- Cast Steel Check Valve, Wafer Ends, Dual Plates
- Spring Loaded, Horizontal or Vertical Lines
- Designed to API594, API6D

Face to Face	API594/API 6D
Wall Thickness	ASME B16.34
End Flange	NPS2~24: ASME B16.5*
Class	ASME/ANSI CL1500

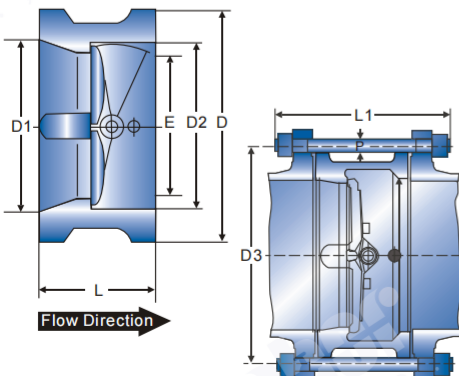

## CLASS 1500 DIMENSION

SIZE (in.)	L	D	D1	D2	W.T (kg)	D3	STUD/BOLTING DETAILS				
							NO.	DIA. in	DIA. mm	LENGTH RF RTJ	
2	70	140	51	58	8	165.0	8	7/8	M24	225	230
2-1/2	83	162	65	73	10	190.5	8	1	M27	250	255
3	83	172	80	90	18	203.0	8	1-1/8	M30	270	275
4	102	207	102	108	25	241.5	8	1-1/4	M33	310	315
5	110	252	127	136	50	292.0	8	1-1/2	M39x3	370	375
6	159	280	150	162	65	317.5	12	1-3/8	M36x3	430	440
8	206	350	200	212	130	393.5	12	1-5/8	M42x3	510	520
10	248	433	254	266	210	482.5	12	1-7/8	M48x3	600	610
12	305	518	305	312	380	571.5	16	2	M52x3	695	715
14	356	576	337	355	550	635.0	16	2-1/4	M56x3	775	800
16	384	639	387	400	630	705.0	16	2-1/2	M64x3	850	880
18	468	701	430	438	790	774.5	16	1-3/4	M70x3	955	985
20	533	753	478	487	1270	832	16	3	M76x3	1065	1095
24	559	897	570	578	2710	990.5	16	3-1/2	M90x3	1170	1205

\*26" and larger are available with ASME/ANSI B16.47 end flanges, either Style A or Style B (formerly MSS SP-44 and API 605).

**LUG DUAL PLATE CHECK VALVE**

- Cast Steel Check Valve, Wafer Ends
- Dual Plates, Fully Lugged, Spring Loaded
- Horizontal or Vertical Lines
- Designed to API594, API6D

Face to Face	API594/API 6D
Wall Thickness	ASME B16.34
End Flange	NPS2~24: ASME B16.5*
Class	ASME/ANSI CL150

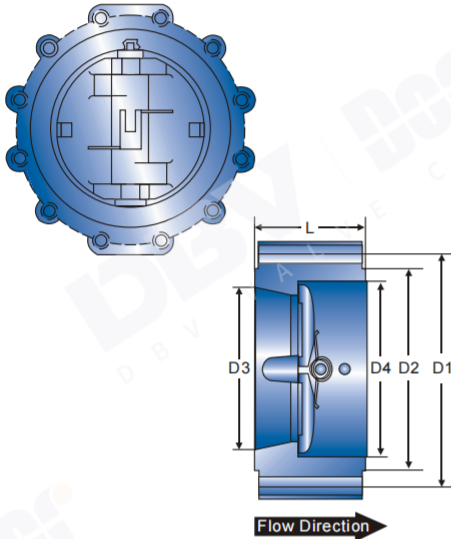

**CLASS 150 DIMENSION**

SIZE (in.)	L	D1	D2	D3	D4	W.T (kg)	HOLE DIA.		STUD/BOLTING DETAILS		LENGTH		
							in	mm	NO.	DIA. in mm	RF	RJ	
2	60	120.5	92	51	56	4	3/4	19	4	5/8	M16	140	155
2-1/2	67	139.5	105	65	73	5.5	3/4	19	4	5/8	M16	150	165
3	73	152.5	127	80	88	7	3/4	19	4	5/8	M16	160	175
4	73	190.5	157	102	108	11	3/4	19	8	5/8	M16	170	185
5	86	216	186	127	132	15	7/8	22	8	3/4	M20	190	205
6	98	241.5	216	152	160	19	7/8	22	8	3/4	M20	205	220
8	127	298.8	270	203	210	36	7/8	22	8	3/4	M20	240	255
10	146	362	324	254	266	61	1	25	12	7/8	M24	270	285
12	181	432	381	305	310	119	1	25	12	7/8	M24	310	325
14	184	476	413	350	355	131	1-1/8	29	12	1	M27	325	340
16	191	540	470	400	405	180	1-1/8	29	16	1	M27	340	355
18	203	578	533	450	455	203	1-1/4	32	16	1-1/8	M30	365	380
20	219	635	584	500	505	275	1-1/4	32	20	1-1/8	M30	385	400
24	222	749.5	692	600	605	314	1-1/4	35	20	1-1/4	M33	405	420
28	305	795.5	762	700	700	910	7/8	22	40	3/4	M20	455	-
30	305	846	813	746	750	1025	7/8	22	44	3/4	M20	455	-
32	305	900	864	796	800	1344	7/8	22	48	3/4	M20	460	-
36	368	1009.5	972	898	910	1536	1	25	44	7/8	M24	540	-
42	432	1171.5	1130	1050	1055	2310	1-1/8	29	48	1	M27	625	-
48	524	1335	1289	1200	1205	3364	1-1/4	32	44	1-1/8	M30	740	-

\* 26" and larger are available with ASME/ANSI B16.47 end flanges, either Style A or Style B (formerly MSS SP-44 and API 605).

**LUG DUAL PLATE CHECK VALVE**

- Cast Steel Check Valve, Wafer Ends
- Dual Plates, Fully Lugged, Spring Loaded
- Horizontal or Vertical Lines
- Designed to API594, API6D

Face to Face	API594/API 6D
Wall Thickness	ASME B16.34
End Flange	NPS2~24: ASME B16.5*
Class	ASME/ANSI CL300

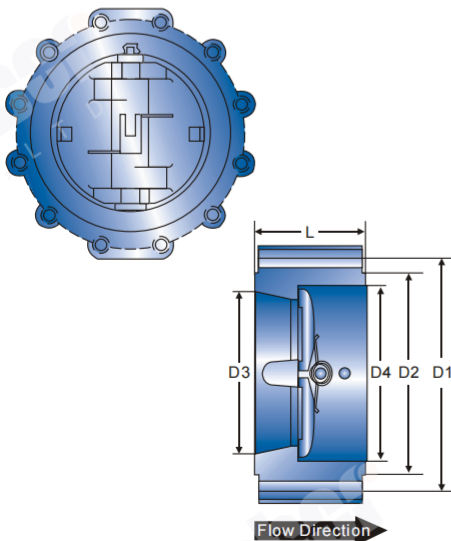

**CLASS 300 DIMENSION**

SIZE (in.)	L	D1	D2	D3	D4	W.T (kg)	HOLE DIA.		STUD/BOLTING DETAILS		LENGTH		
							in	mm	NO.	DIA. in mm	RF	RJ	
2	60	127	92	51	58	6	3/4	19	8	5/8	M16	155	175
2-1/2	67	149	105	65	73	7	7/8	22	8	3/4	M20	175	195
3	73	168.5	127	80	88	10	7/8	22	8	3/4	M20	190	210
4	73	200	157	102	108	16	7/8	22	8	3/4	M20	175	215
5	86	235	186	127	132	29	7/8	22	8	3/4	M20	215	235
6	98	270	216	152	160	32	7/8	22	12	3/4	M20	230	250
8	127	330	270	203	210	55	1	25	12	7/8	M24	280	300
10	146	387.5	324	254	266	82	1-1/8	29	16	1	M27	315	335
12	181	451	381	305	310	92	1-1/4	32	16	1-1/8	M30	365	385
14	222	514.5	413	350	355	251	1-1/4	32	20	1-1/8	M30	410	430
16	232	571.5	470	405	405	342	1-3/8	35	20	1-1/4	M33	435	455
18	264	628.5	533	455	455	391	1-3/8	35	24	1-1/4	M33	475	495
20	292	686	584	505	505	536	1-3-8	35	24	1-1/4	M33	510	535
24	318	813	692	608	608	833	1-5/8	41	24	1-1/2	M39	560	585
30	368	921	845	735	740	1395	1-1/2	38	36	1-3/8	M36	650	-
36	483	1089	1010	873	880	1862	1-3/4	45	32	1-5/8	M42	800	-
42	568	1245	1168	1035	1045	3861	1-7/8	48	36	1-3/4	M45	920	-
48	629	1416	1327	1179	1190	4370	2	51	40	1-7/8	M48	1010	-

\* 26" and larger are available with ASME/ANSI B16.47 end flanges, either Style A or Style B (formerly MSS SP-44 and API 605).

# Gate, Globe, Check Valve

## LUG DUAL PLATE CHECK VALVE

- Cast Steel Check Valve, Wafer Ends
- Dual Plates, Fully Lugged, Spring Loaded
- Horizontal or Vertical Lines
- Designed to API594, API6D

Face to Face	API594/API 6D
Wall Thickness	ASME B16.34
End Flange	NPS2~24: ASME B16.5*
Class	ASME/ANSI CL600/900

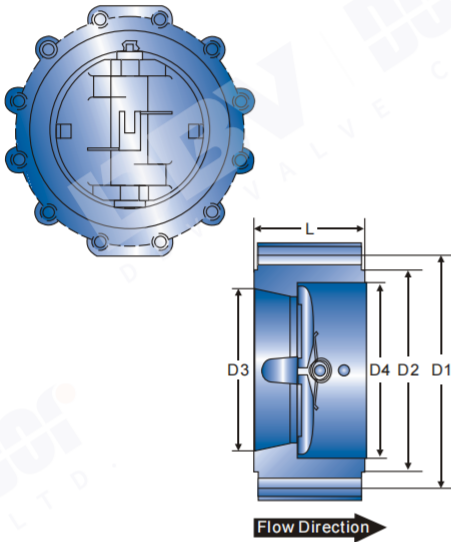

## CLASS 600 DIMENSION

SIZE (in.)	L	D1	D2	D3	D4	W.T (kg)	HOLE DIA.		STUD/BOLTING DETAILS		LENGTH		
							in	mm	NO.	DIA.	RF	RJ	
2	60	127	92	51	58	6.5	3/4	19	8	5/8	M16	175	180
2-1/2	67	149	100	65	73	8	7/8	22	8	3/4	M20	195	200
3	73	168	127	80	88	10	7/8	22	8	3/4	M20	210	215
4	79	216	157	102	108	21	1	25	8	7/8	M24	235	240
5	105	266.5	186	127	136	41	1-1/8	29	8	1	M27	280	285
6	136	292	216	152	162	57	1-1/8	29	12	1	M27	320	325
8	165	349	270	200	212	94	1-1/8	32	12	1-1/8	M30	370	375
10	213	432	324	250	266	164	1-3/8	35	16	1-1/4	M33	440	445
12	229	489	381	305	312	213	1-3/8	35	20	1-1/4	M33	460	465
14	273	527	413	337	355	343	1-1/2	38	20	1-3/8	M36	520	525
16	305	603	470	387	400	476	1-5/8	41	20	1-1/2	M39	575	580
18	362	654	533	438	450	685	1-3/4	44	20	1-5/8	M42	650	655
20	368	724	584	489	500	908	1-3/4	44	24	1-5/8	M42	670	680
24	438	838	692	591	600	1088	2	52	24	1-7/8	M48	780	790

## CLASS 900 DIMENSION

SIZE (in.)	L	D1	D2	D3	D4	W.T (kg)	HOLE DIA.		STUD/BOLTING DETAILS		LENGTH		
							in	mm	NO.	DIA.	RF	RJ	
2	70	165.1	92	51	58	13	1	26	8	7/8	M24	225	230
2-1/2	83	190.5	105	65	73	18	1-1/8	29	8	1	M27	250	255
3	83	190.5	127	80	90	21	1	26	8	7/8	M24	240	245
4	102	234.9	157	102	108	36	1-1/4	32	8	1-1/8	M30	285	290
5	110	279.4	186	127	136	65	1-3/8	35	8	1-1/4	M33	310	315
6	159	317.5	216	150	162	92	1-1/4	32	12	1-3/8	M30	365	370
8	206	393.7	270	200	212	174	1-1/2	39	12	1-3/8	M36	440	445
10	241	469.9	324	250	266	264	1-1/2	39	16	1-3/8	M36	490	495
12	292	533.4	381	305	312	211	1-1/2	39	20	1-3/8	M36	560	565
14	356	558.8	413	337	355	612	1-5/8	42	20	1-1/2	M39	645	655
16	384	615.9	470	387	400	712	1-3/4	45	20	1-5/8	M42	685	695
18	451	685.8	533	438	450	1160	2	51	20	1-7/8	M48	790	805
20	451	749.3	584	487	496	1568	2-1/8	54	20	2	M52	810	825
24	495	901.7	692	591	600	1881	2-5/8	67	20	2-1/2	M64	945	965

## LUG DUAL PLATE CHECK VALVE

- Cast Steel Check Valve, Wafer Ends
- Dual Plates, Fully Lugged, Spring Loaded
- Horizontal or Vertical Lines
- Designed to API594, API6D

Face to Face	API594/API 6D
Wall Thickness	ASME B16.34
End Flange	NPS2~24: ASME B16.5*
Class	ASME/ANSI CL1500

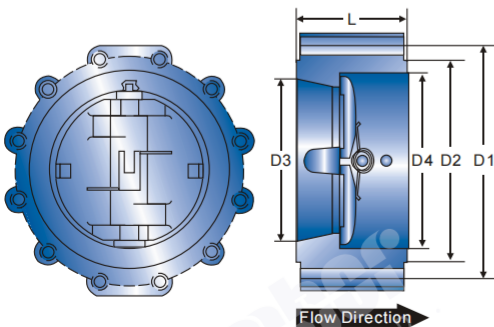

## CLASS 1500 DIMENSION

SIZE (in.)	L	D1	D2	D3	D4	W.T (kg)	HOLE DIA.		STUD/BOLTING DETAILS		LENGTH		
							in	mm	NO.	DIA.	RF	RJ	
2	70	165.1	58	92	51	14	1	26	8	7/8	M24	225	230
2-1/2	83	190.5	73	105	65	19	1-1/8	29	8	1	M27	250	255
3	83	203.2	90	127	80	25	1-1/4	32	8	1-1/8	M30	270	275
4	102	241.3	108	157	102	43	1-3/8	35	8	1-1/4	M33	310	315
5	110	292.1	136	186	127	72	1-5/8	42	8	1-1/2	M39	370	375
6	159	317.5	162	216	150	101	1-1/2	39	12	1-3/8	M36	430	440
8	206	393.7	212	270	200	240	1-3/4	45	12	1-5/8	M42	510	520
10	248	482.6	266	324	254	306	2	51	12	1-7/8	M48	600	610
12	305	571.5	312	381	305	541	2-1/8	54	16	2	M52	695	715
14	356	635	355	413	337	932	2-3/8	61	16	2-1/4	M56	775	800
16	384	704.8	400	470	387	980	2-5/8	67	16	2-1/2	M64	850	880

\* 26" and larger are available with ASME/ANSI B16.47 end flanges, either Style A or Style B (formerly MSS SP-44 and API 605).

**FLANGED DUAL PLATE CHECK VALVE**

- Cast Steel Check Valve, Double Flanged Ends
- Dual Plates, Spring Loaded
- Horizontal or Vertical Lines
- Designed to API594, API6D

Face to Face	API594/API 6D
Wall Thickness	ASME B16.34
End Flange	NPS2~24: ASME B16.5*
Class	ASME/ANSI CL150/300

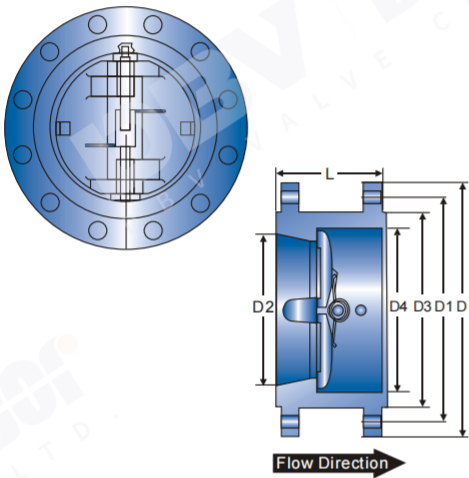

**CLASS 150 DIMENSION**

SIZE (in.)	L	D	D1	D2	D3	D4	W.T (kg)	HOLE DIA.		NO.	STUD/BOLTING DETAILS DIA.		LENGTH	
								in	mm		in	mm	RF	RJ
8	127	343	298.5	203	270	210	63	7/8	22	8	3/4	M20	120	135
10	146	406	362	254	324	266	93	1	25	12	7/8	M24	135	150
12	181	483	432	305	381	310	170	1	25	12	7/8	M24	135	150
14	184	533	476	350	413	355	199	1-1/8	29	12	1	M27	145	160
16	191	597	540	400	470	405	246	1-1/8	29	16	1	M27	155	170
18	203	635	578	450	533	455	290	1-1/4	32	16	1-1/8	M30	165	180
20	219	699	635	500	584	505	348	1-1/4	32	20	1-1/8	M30	170	185
24	222	813	749.5	600	692	605	396	1-1/4	35	20	1-1/4	M33	185	200
28	305	837	795.5	700	762	700	1270	7/8	22	40	3/4	M20	205	
30	305	887	846	746	813	750	1987	7/8	22	44	3/4	M20	210	
32	305	941	900	796	864	800	2925	7/8	22	48	3/4	M20	225	
36	368	1057	1009.5	898	972	910	1430	1	25	44	7/8	M24	250	
42	432	1226	1171.5	1050	1130	1055	2377	1-1/8	29	48	1	M27	275	
48	524	1392	1335	1200	1289	1205	4174	1-1/4	32	44	1-1/8	M30	305	

**CLASS 300 DIMENSION**

SIZE (in.)	L	D	D1	D2	D3	D4	W.T (kg)	HOLE DIA.		NO.	STUD/BOLTING DETAILS DIA.		LENGTH	
								in	mm		in	mm	RF	RJ
8	381	127	330	203	210	270	78	1	25	12	7/8	M24	155	175
10	445	146	387.5	254	266	324	115	1-1/8	29	16	1	M27	175	195
12	521	181	451	305	310	381	242	1-1/4	32	16	1-1/8	M30	185	205
14	584	222	514.5	350	355	413	360	1-1/4	32	20	1-1/8	M30	195	215
16	648	232	571.5	400	405	470	489	1-3/8	35	20	1-1/4	M33	205	225
18	711	264	628.5	450	455	533	558	1-3/8	35	24	1-1/4	M33	210	230
20	775	292	686	500	505	584	766	1-3/8	35	24	1-1/4	M33	215	230
24	914	318	813	600	608	692	1190	1-5/8	41	24	1-1/2	M39	250	265
30	991	368	921	735	740	845	1996	1-1/2	38	369	1-3/8	M36	290	
36	1172	483	1089	873	880	1010	2660	1-3/4	45	32	1-5/8	M42	325	
42	1334	568	1245	1035	1045	1168	5515	1-7/8	48	36	1-3/4	M45	360	
48	1511	629	1416	1179	1190	1327	6239	2	51	40	1-7/8	M48	400	

**DUAL PLATES DOUBLE FLANGED CHECK VALVE**

- Cast Steel Check Valve, Double Flanged Ends
- Dual Plates, Spring Loaded
- Horizontal or Vertical Lines
- Designed to API594, API6D

Face to Face	API594/API 6D
Wall Thickness	ASME B16.34
End Flange	NPS2~24: ASME B16.5*
Class	ASME/ANSI CL600

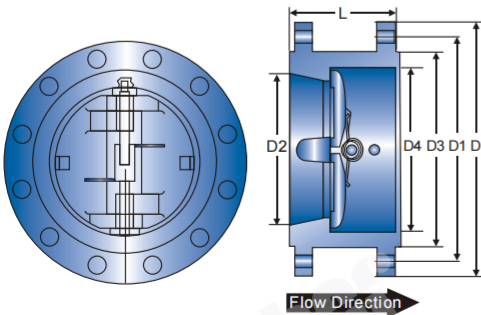

**CLASS 600 DIMENSION**

SIZE (in.)	L	D	D1	D2	D3	D4	W.T (kg)	HOLE DIA.		NO.	STUD/BOLTING DETAILS DIA.		LENGTH	
								in	mm		in	mm	RF	RJ
8	165	419	349	200	270	212	134	1-1/4	32	12	1-1/8	M30	210	215
10	213	508	432	250	324	266	234	1-3/8	35	16	1-1/4	M33	230	235
12	229	559	489	305	381	312	304	1-3/8	35	20	1-1/4	M33	240	245
14	273	603	527	337	416	355	490	1-1/2	39	20	1-3/8	M36	260	265
16	305	686	603	387	470	400	680	1-5/8	41	20	1-1/2	M39	280	285
18	362	743	654	438	533	450	978	1-3/4	44	20	1-5/8	M42	295	300
20	368	813	724	489	584	500	1297	1-3/4	44	24	1-5/8	M42	310	315
24	438	940	838	591	692	600	1554	2	52	24	1-7/8	M48	350	360

\* 26" and larger are available with ASME/ANSI B16.47 end flanges, either Style A or Style B (formerly MSS SP-44 and API 605).



# Gate, Globe, Check Valve

## FLANGED DUAL PLATE CHECK VALVE

- Cast Steel Check Valve, Double Flanged Ends
- Dual Plates, Spring Loaded
- Horizontal or Vertical Lines
- Designed to API594, API6D

Face to Face	API594/API 6D
Wall Thickness	ASME B16.34
End Flange	NPS2~24: ASME B16.5*
Class	ASME/ANSI CL900/1500

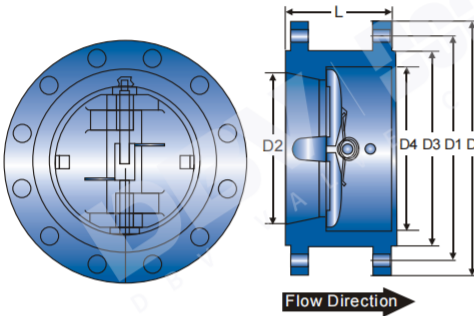

## CLASS 900 DIMENSION

SIZE (in.)	L	D	D1	D2	D3	D4	W.T (kg)	STUD/BOLTING DETAILS						
								HOLE DIA. in	HOLE DIA. mm	NO.	DIA. in	DIA. mm	LENGTH RF RJ	
8	206	470	393.7	200	270	212	217	1-1/2	39	12	1-3/8	M36	245	250
10	241	545	469.9	250	324	266	330	1-1/2	39	16	1-3/8	M36	260	265
12	292	610	533.4	305	381	312	509	1-1/2	39	20	1-3/8	M36	275	280
14	356	640	558.8	337	413	355	765	1-5/8	42	20	1-1/2	M39	295	305
16	384	705	615.9	387	470	400	890	1-3/4	45	20	1-5/8	M42	305	315
18	451	785	685.8	438	533	450	1450	2	51	20	1-7/8	M48	350	365
20	451	855	749.3	487	584	496	1960	2-1/8	54	20	2	M52	370	385
24	495	1040	901.7	591	692	600	2351	2-5/8	69	20	2-1/2	M64	470	490

## CLASS 1500 DIMENSION

SIZE (in.)	L	D	D1	D2	D3	D4	W.T (kg)	STUD/BOLTING DETAILS						
								HOLE DIA. in	HOLE DIA. mm	NO.	DIA. in	DIA. mm	LENGTH RF RJ	
8	206	483	393.7	200	270	212	283	1-3/4	45	12	1-5/8	M42	315	325
10	248	585	482.6	254	324	266	361	2	51	12	1-7/8	M48	365	375
12	305	675	571.5	305	381	312	637	2-1/8	54	16	2	M52	400	415
14	356	750	635	337	413	355	1097	2-3/8	61	16	2-1/4	M56	435	455
16	381	825	704.8	387	470	400	1152	2-5/8	67	16	2-1/2	M64	480	505

\* 26" and larger are available with ASME/ANSI B16.47 end flanges, either Style A or Style B (formerly MSS SP-44 and API 605).

## HUB ENDS DUAL PLATE CHECK VALVE

- Cast Steel Check Valve, Hub Ends
- Dual Plates, Spring Loaded
- Horizontal or Vertical Lines
- Designed to API594, API6D

Face to Face	API594/API 6D
Wall Thickness	ASME B16.34
End Flange	ASME B16.5*
Class	ASME/ANSI CL600~CL2500

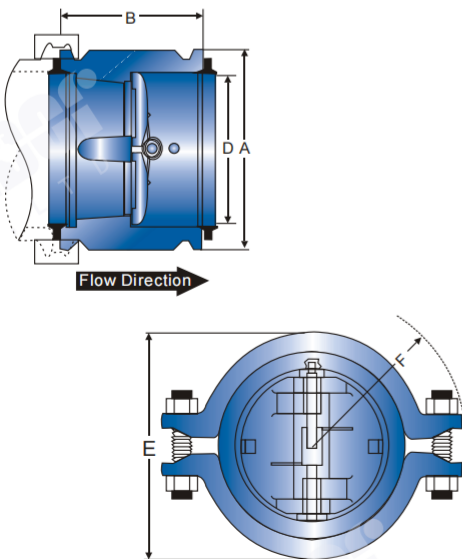

## CLASS 600~2500 DIMENSION

SIZE (in.)	SEAT RING NO.	A	B	D	E	F	W.T (kg)	
2	20	3.63	4.50	2.06	5.06	4.50	5	
	14	3.63	4.50	1.16	5.06	4.50	5	
3	27	5.00	4.50	3.06	6.88	5.25	9	
	25	5.00	4.50	2.67	6.88	5.25	9	
	20	5.00	4.50	2.06	6.88	5.25	9	
4	40	6.00	5.00	2.06	8.13	6.00	11	
	34	6.00	5.00	3.69	8.13	6.00	11	
	31	6.00	5.00	3.25	8.13	6.00	11	
	25	6.00	5.00	2.67	8.13	6.00	15	
	6	9.25	6.25	6.07	12.00	8.75	35	
6	52	9.25	6.25	5.31	12.00	8.75	35	
	46	9.25	6.25	4.75	12.00	8.75	35	
	40	9.25	6.25	4.06	12.00	8.75	40	
	8	82	11.50	8.13	8.25	14.50	9.88	72
	76	11.50	8.13	7.75	14.50	9.88	72	
8	72	11.50	8.13	7.25	14.50	9.88	72	
	62	11.50	8.13	6.07	14.50	9.88	83	
	52	11.50	8.13	5.31	14.50	9.88	83	
	10	H97	13.63	9.75	9.88	17.63	12.75	110
	H94	13.63	9.75	9.50	17.63	12.75	110	
10	H84	13.63	9.75	8.50	17.63	12.75	140	
	H82X	13.63	9.75	8.25	18.25	13.50	140	
	H72	13.63	9.75	7.25	18.25	12.75	140	
	H62	13.63	9.75	6.07	18.25	12.75	157	
	H62X	13.63	9.75	6.07	18.25	13.50	157	
	12	M120	16.00	12.50	12.00	20.25	14.50	177
	M112	16.00	12.50	11.25	20.25	14.50	177	
M102	16.00	12.50	10.25	20.25	14.50	228		
12	M82	16.00	12.50	8.25	20.25	14.50	268	
	M82X	16.00	12.50	8.25	20.50	15.75	268	

\* 26" and larger are available with ASME/ANSI B16.47 end flanges, either Style A or Style B (formerly MSS SP-44 and API 605).

## SINGLE DISC SWING WAFER CHECK VALVE

- Cast Steel Check Valve, Wafer Ends
- Single Disc, Spring Loaded
- Horizontal or Vertical Lines
- Designed to API594, API6D

Face to Face	API594/API 6D
Wall Thickness	ASME B16.34
End Flange	ASME B16.5
Class	ASME/ANSI CL150/300

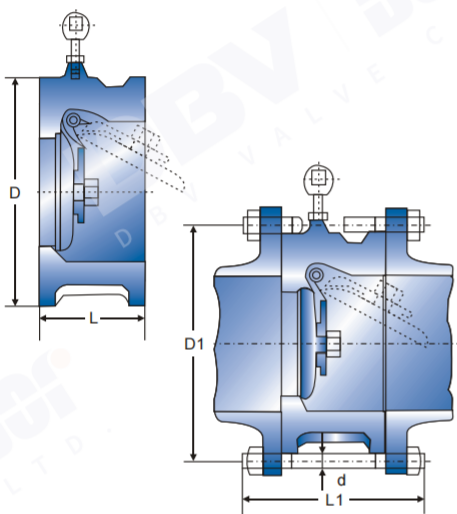

## SINGLE DISC WAFER CHECK VALVE

- Cast Steel Check Valve, Wafer Ends
- Single Disc, Spring Loaded
- Horizontal or Vertical Lines
- Designed to EN Standard

Face to Face	EN Standard
Wall Thickness	ASME B16.34
End Flange	EN Standard
Class	PN10/16/25/40

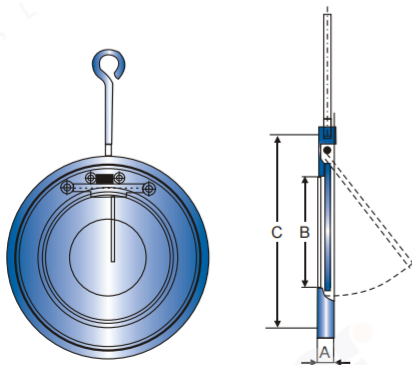

## CLASS 150 DIMENSION

SIZE (in.)	L	D	W.T (kg)	P.C.D D1	NO.	STUD/BOLTING DETAILS		LENGTH	
						DIA. in	mm	RF	RJ
2	60	103	3	120.5	4	5/8	M16	140	155
2-1/2	67	122	4	139.5	4	5/8	M16	150	165
3	73	135	5	152.5	4	5/8	M16	160	175
4	73	173	8	190.5	8	5/8	M16	170	185
5	86	195	10	216.0	8	3/4	M20	190	205
6	96	220	16	241.5	8	3/4	M20	205	220
8	127	277	30	298.5	8	3/4	M20	240	255
10	146	337	47	362.0	12	7/8	M24	270	285
12	181	407	65	432.0	12	7/8	M24	310	325
14	184	448	102	476.0	12	1	M27	325	340
16	191	512	137	540.0	16	1	M27	340	355
18	203	547	166	578.0	16	1-1/8	M30	365	380
20	219	604	193	635.0	20	1-1/8	M30	385	400
24	222	715	397	749.5	20	1-1/4	M33	405	420

## CLASS 300 DIMENSION

SIZE (in.)	L	D	W.T (kg)	P.C.D D1	NO.	STUD/BOLTING DETAILS		LENGTH	
						DIA. in	mm	RF	RJ
2	60	110	4	127.0	8	5/8	M16	155	175
2-1/2	67	128	5	149.0	8	3/4	M20	175	195
3	73	147	7	168.5	8	3/4	M20	190	210
4	73	179	10	200.0	8	3/4	M20	195	215
5	86	214	18	235.0	8	3/4	M20	215	235
6	98	249	22	270.0	12	3/4	M20	230	250
8	127	305	37	300.0	12	7/8	M24	280	300
10	146	359	61	387.5	16	1	M27	315	335
12	181	420	92	451.0	16	1-1/8	M30	365	385
14	222	483	140	514.5	20	1-1/8	M30	410	430
16	232	537	228	571.5	20	1-1/4	M33	435	455
18	264	594	240	628.5	24	1-1/4	M33	475	495
20	292	652	318	686.0	24	1-1/4	M33	510	535
24	318	772	492	813.0	24	1-1/2	M39	560	585

## PN10 DIMENSION

SIZE DN	50	65	80	100	125	150	200	250	300	350	400	450	500	600
A	19	19	19	19	19	19	29	29	38	44	51	60	64	70
B	25	38	46	72	95	114	144	188	220	266	305	356	406	485
C	108	128	142	162	192	218	273	328	380	438	489	539	594	696
W.T (kg)	1.2	1.6	2.2	2.7	3.8	5.8	14	17.5	27	41.5	60	74	116	178

## PN16 DIMENSION

SIZE DN	50	65	80	100	125	150	200	250	300	350	400	450	500	600
A	19	19	19	19	19	19	29	29	38	44	51	60	64	70
B	25	38	46	72	95	114	144	188	220	266	305	356	406	485
C	108	128	142	162	192	218	273	329	384	444	496	556	618	732
W.T (kg)	1.2	1.6	2.2	2.7	3.8	5.8	14	17.5	28	41.5	60	78	128	180

## PN25 DIMENSION

SIZE DN	50	65	80	100	125	150	200	250	300	350	400	450	500	600
A	19	19	19	19	19	22	29	38	51	51	51	76	83	83
B	25	38	46	72	95	114	144	188	220	266	305	356	406	485
C	108	128	142	168	194	224	284	341	401	458	515	565	622	732
W.T (kg)	1.9	2.3	2.6	3.4	4.4	6.4	16	21	38	53	68	103	150	205

## PN40 DIMENSION

SIZE DN	50	65	80	100	125	150	200	250	300	350	400	450	500	600
A	19	19	19	19	19	22	29	38	51	51	51	76	83	83
B	25	38	46	72	95	114	144	188	220	266	305	356	406	485
C	108	128	142	168	194	224	291	353	418	475	547	572	626	745
W.T (kg)	1.9	2.3	2.6	3.4	4.4	6.4	17	24	45	62	78	114	158	215

# Gate, Globe, Check Valve

## LIFT WAFER CHECK VALVE

- Cast Steel Check Valve, Wafer Ends
- Lift Type, Spring Loaded
- Horizontal or Vertical Lines
- Designed to API594, API6D

Face to Face	API594/API 6D
Wall Thickness	ASME B16.34
End Flange	ASME B16.5
Class	ASME/ANSI CL150

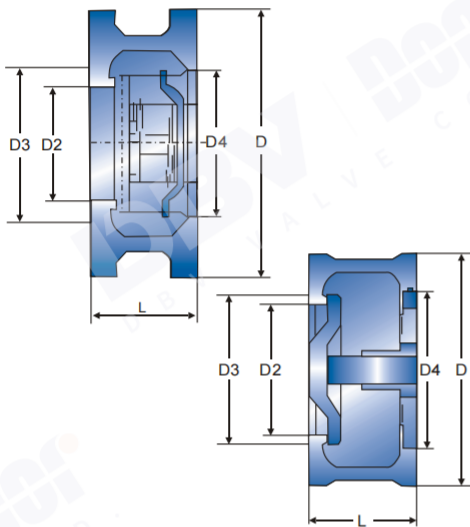

## CLASS 150 DIMENSION

SIZE (in.)	L	D	D2	D3	D4	W.T (kg)	P.C.D D1	STUD/BOLTING DETAILS				
								NO.	DIA. in	DIA. mm	LENGTH RF	LENGTH RJ
1/2	25	46	15	25	25	0.28	60.5	4	1/2	M14	90	-
3/4	31.5	56	19	30	30	0.42	70	4	1/2	M14	100	-
1	35.5	65	24	36	36	0.56	79.5	4	1/2	M14	105	120
1-1/4	40	74	31	43	43	0.75	89	4	1/2	M14	115	130
1-1/2	45	84	39	52	52	1.3	98.5	4	1/2	M14	120	135
2	56	103	48	62	62	2.1	120.5	4	5/8	M16	140	155
2-1/2	63	122	62	75	75	2.8	139.5	4	5/8	M16	155	170
3	71	135	76	90	90	3.6	152.5	4	5/8	M16	165	180
4	80	173	95	112	112	4.8	190.5	8	5/8	M16	175	190
5	110	195	110	125	132	12	216.0	8	3/4	M20	210	225
6	125	220	127	150	158	17	241.5	8	3/4	M20	230	245
8	160	277	165	200	208	29	298.5	8	3/4	M20	270	285



## LIFT WAFER CHECK VALVE

- Cast Steel Check Valve, Wafer Ends
- Lift Type, Spring Loaded
- Horizontal or Vertical Lines
- Designed to API594, API6D

Face to Face	API594/API 6D
Wall Thickness	ASME B16.34
End Flange	ASME B16.5
Class	ASME/ANSI CL300

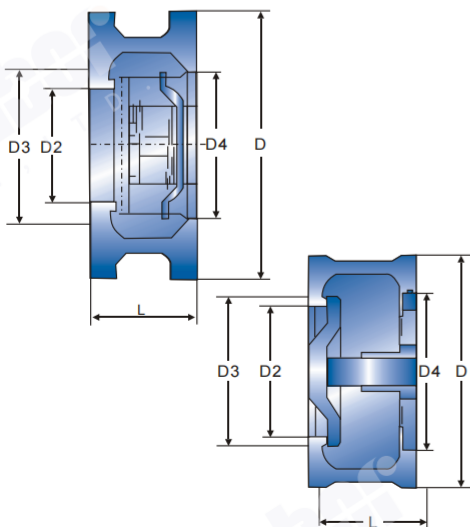

## CLASS 300 DIMENSION

SIZE (in.)	L	D	D2	D3	D4	W.T (kg)	P.C.D D1	STUD/BOLTING DETAILS				
								NO.	DIA. in	DIA. mm	LENGTH RF	LENGTH RJ
1/2"	25	52	15	25	25	0.3	66.5	4	1/2	M14	95	105
3/4	31.5	65	19	30	30	0.46	82.5	4	5/8	M16	110	125
1	35.5	72	24	36	36	0.6	89	4	5/8	M16	115	130
1-1/4	40	81	31	43	43	0.8	98.5	4	5/8	M16	125	140
1-1/2	45	94	39	52	52	1.5	114.5	4	3/4	M20	140	155
2	56	110	48	62	62	2.4	127.0	8	5/8	M16	145	170
2-1/2	63	128	62	75	75	3	149.0	8	3/4	M20	170	190
3	71	147	76	91	91	4	168.5	8	3/4	M20	185	205
4	80	179	95	112	112	5.5	200.0	8	3/4	M20	200	220
5	110	214	110	125	132	13	235.0	8	3/4	M20	235	255
6	125	249	127	150	158	22	270.0	12	3/4	M20	255	275
8	160	305	165	200	208	36	330.0	12	7/8	M24	305	325



## STANDARD DESIGN FEATURES OF DBV PRESSURE SEAL VALVES

DBV Pressure Seal valves are intended for high pressure, high temperature applications in all types of fluid except where severe coking is a factor. The design and material selections provide excellent service in steam-generation stations, industrial chemical plants and thermal power plants.

Most Pressure Seal valves are offered in Cast Steel and Forged Steel body designs. These options make the DBV Pressure Seal product line an excellent choice for users with various application requirements.

DBV Pressure Seal valves provide the most efficient flow passage and sealing features possible, resulting in significant weight savings, easy installation and in-line maintenance.

## GENERAL DESIGN SPECIFICATIONS

DBV Pressure Seal Valves are manufactured and tested in strict accordance with the following standards:

\*ASME B16.34 \*ASME B16.10 \*ASME B16.25 \*API 598

## STANDARD CONSTRUCTION FEATURES

### BODY

Flow areas are specifically designed for minimum turbulence and pressure drop.

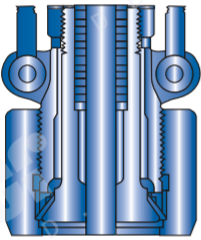

Bonnet Type A

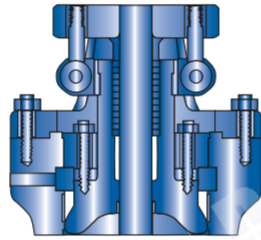

Bonnet Type B

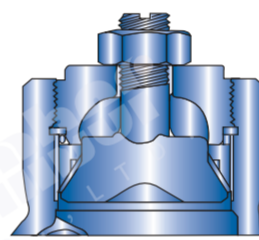

Bonnet Type C

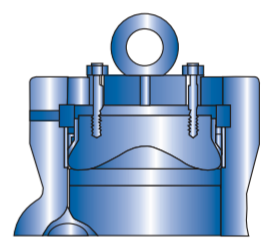

Bonnet Type D

Gate  
Class 600, 900, 1500 & 2500  
Size 4" and smaller

Globe  
Class 600, 900 & 1500  
Size 4" and smaller

Class 2500  
Size 3" and smaller

Gate  
Class 600, 900, 1500 & 2500  
Size 6" and larger

Globe  
Class 600, 900 & 1500  
Size 6" and larger

Class 2500  
Size 4" and larger

### BONNET

Ample stuffing box area, Stellite stem guide surface and back seat shoulder for accurate guiding of the stem and back seat.

Swing Check  
Class 600, 900 & 1500  
Size 4" and smaller

Class 2500  
Size 3" and smaller

Swing Check  
Class 600, 900 & 1500  
Size 6" and larger

Class 2500  
Size 4" and larger

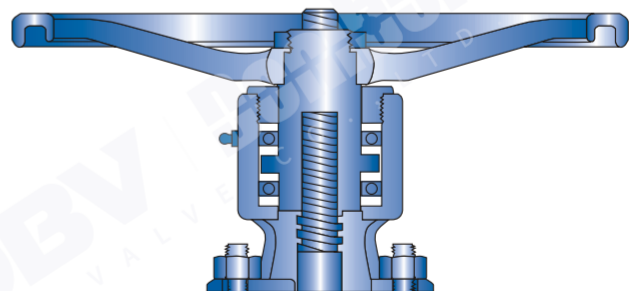

## YOKE SLEEVE BALL BEARING-TYPE EQUIPPED VALVES

Class	Gate	Globe
600	Size 6" and larger	Size 6" and larger
900	Size 2", 2 1/2" and 6" and larger	Size 6" and larger
1500	Size 2" and larger	Size 6" and larger
2500	Size 2" and larger	Size 3" and larger

## BALL BEARING-TYPE YOKE SLEEVE

Large, high-pressure valves can require a tremendous amount of torque to open and close. By utilizing ball bearings in the yoke sleeve, the operating torques of these difficult-to-operate valves are reduced by as much as 50 percent.

Hammer blow wheels are furnished on sizes 6" and larger globe valves.

# Gate, Globe, Check Valve

## STANDARD CONSTRUCTION FEATURES

### FLEXIBLE WEDGE SEALING DESIGN (GATE VALVES)

The flexible wedge is a one-piece, fully guided cast wedge with a central hub to allow the seating faces to move relative to each other, thus compensating for distortion of the body seats due to thermal expansion or piping loads. Seating and wedge seating face are set at an angle from vertical to minimize sliding contact of the wedge and seat ring during opening and closing. Wedging action helps effect a tight seal in low differential pressure services. Flexible wedge construction resists wedge sticking or binding in services where the valve may be closed when cold and opened when hot. Seating surfaces are hardfaced with Stellite to provide high cycle capability in very high differential pressure services.

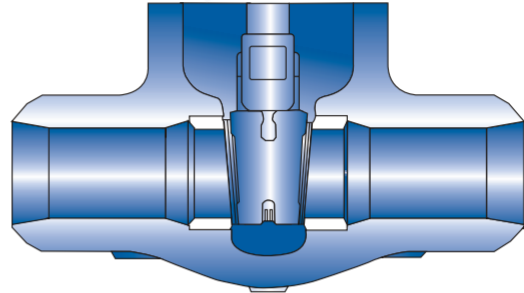

### PARALLEL SLIDE DESIGN (GATE VALVES)

The gate is a split design using two discs spring loaded and held together by a gate holder with an Inconel 750 spring to provide initial energizing when closed. The gate relies for seat tightness on the primary fluid pressure acting on the downstream half. There is no wedging action or extra loading on the seats resulting in considerably lower operating torque. When the valve is in the open position the gate is completely clear of these seats. During closing there is a bevel on the bottom of the gate to guide it in between the seats and recompress the spring. Seating surfaces are hardfaced with Stellite to provide high cycle capability in very high differential pressure services.

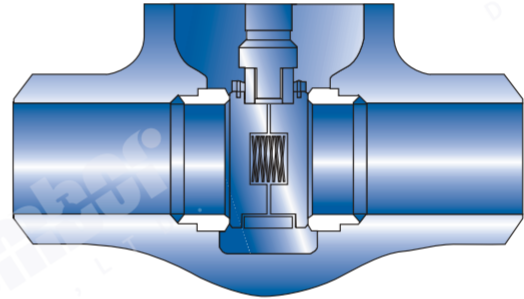

### STRAIGHT AND Y-PATTERN SEATING DESIGN (GLOBE VALVES)

All DBV globe valves utilize the same seating design which consist of guided disc which seals fully with the seat to provide an effective tight seal. Seating surfaces are hardfaced with Stellite to increase the cycle life.

All DBV globe valves are unidirectional. A non-return stop check feature is available on request.

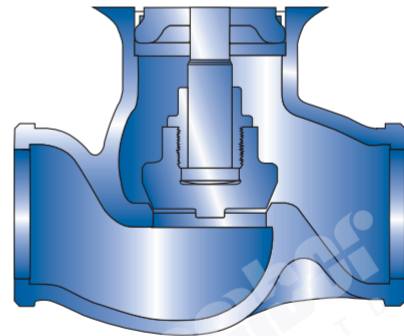

## ENGINEERING AND DESIGN OPTIONS

Live Loading Options  
(Gate & Globe Valves)

Live loading extends low emission service life especially in service in high pressure and temperature conditions, Frequent Cycling or where it is desirable to eliminate the need for occasional adjustment of the packing to compensate for the variations during operation

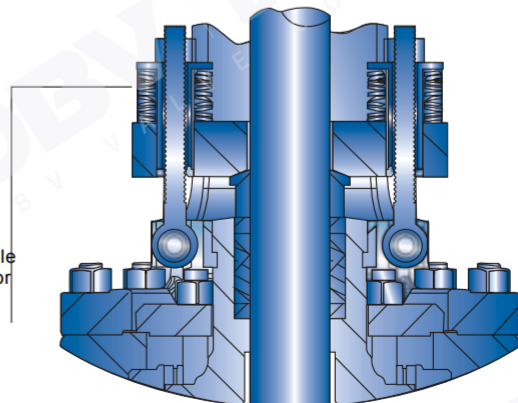

## STANDARD CONSTRUCTION FEATURES SWING CHECK AND TILT DISC (CHECK VALVES)

Pressure Seal check valves are designed for reliability in high velocity service applications to prevent backflow. The check valves are designed to operate in either vertical or horizontal pipe runs. Seating surfaces are hard faced with Stellite to provide high cycle capability.

The swing check design offers better flow characteristics than a tilting disc design with higher flow area. The tilting disc is a non-slam design which minimizes the potential for water hammer.

Pressure Seal tilting check valves feature a fitted disc that's guided to ensure an effective tight seal and to minimize vibration.

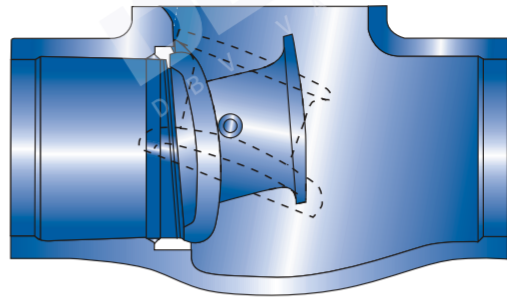

Tilt Disc Check Valve

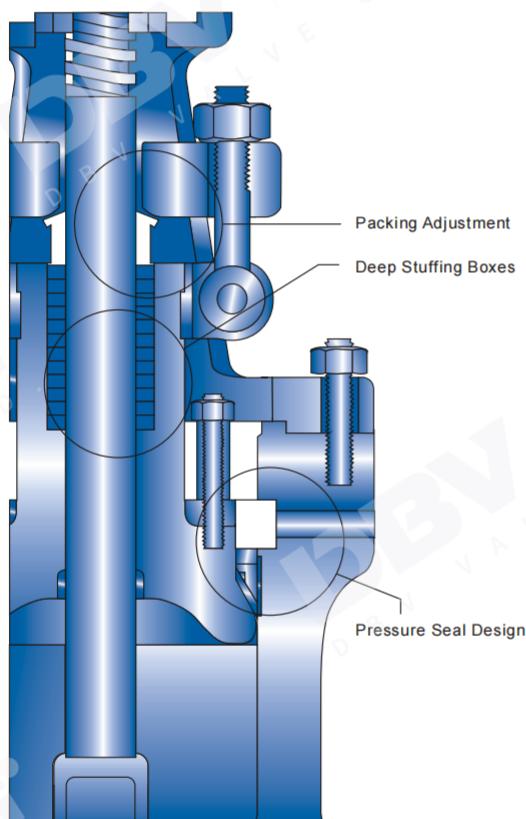

## SPECIAL FEATURES OF ALL PRESSURE SEAL GATE AND GLOBE VALVES

### PACKING ADJUSTMENT

All gate and globe valves are provided with a two-piece packing gland to minimize the possibility of scoring the stem if the gland is tightened unevenly. Eyebolts remain fastened to the bonnet. The eyebolt swings out of the way to simplify packing replacement, and are oriented so they can be adjusted from one side of the valve.

### DEEP STUFFING BOXES

Deep stuffing boxes are standard on gate and globe valves. The design provides extra packing for a more reliable stem seal, or sufficient depth for packing with an optional lantern ring in the middle. When equipped with a lantern ring, a tapped and plugged hole is provided; when specified, it can be fitted with an injection fitting.

### PRESSURE SEAL DESIGN

The segmental thrusting absorbs all the thrust applied by internal pressure. A hardened Stainless Steel protective ring prevents deformation of the top surface of the soft steel, 304 Stainless or 316 Stainless with a high density graphite gasket. The gasket can be removed freely without damaging the sealing surface of the body.

A single warranty then applies to each modified product, with each product inspected for quality and conformance to our customer's specifications and industry standards.

## AVAILABLE MODIFICATIONS FOR DBV PRESSURE SEAL VALVES

- Gear Operator Mounting
- Trim Changes
- Actuation
- Cryogenic Gas Columns
- Hand Wheel Extensions
- Drilled & Tapped Body/Bonnet Connections
- By-Pass
- Pressure Equalizing
- Acid Shields
- Oxygen & Chlorine Cleaning & Packaging
- Weld End Bore Changes

- Customer Specified Coatings
- Outside Lever and Weight for Check Valves
- Slam Retarders for Check Valves
- Chain Wheel Operator

## NDE TESTING AVAILABLE

- Dye Penetrant Test
- Magnetic Particle Test
- Radiography
- PMI (Positive Material Identification)
- API/ANSI Performance Testing

# Gate, Globe, Check Valve

## PRESSURE SEAL GATE VALVES, CAST STEEL FLEXIBLE TAPER WEDGE DESIGN PARTS AND MATERIALS CLASS 600, 900, 1500 & 2500

Item	Part Name	WCB	WC6	WC9	C5	C12	CF8M
1	Body	A216-WCB	A217-WC6	A217-WC9	A217-C5	A217-C12	A351-CF8M
2	Bonnet	A216-WCB	A217-WC6	A217-WC9	A217-C5	A217-C12	A351-CF8M
3	Wedge	A216-WCB+HF	A217-WC6+HF	A217-WC9+HF	A217-C5+HF	A217-C12+HF	A351-CF8M+HF
4	Stem	A479-410	A479-410	A479-410	A479-410	A479-410	A479-316
5	Handwheel	A197 or WCB	A197 or WCB	A197 or WCB	A197 or WCB	A197 or WCB	A197 or WCB
6	Body seat Ring	C/S 1020+HF	A182 F11+HF	A182 F22+HF	A182 F5a+HF	A182 F9+HF	240 316+HF
7	Backseat	A216-WCB+13Cr	A217-WC6+13Cr	A217-WC9+13Cr	A217-C5+13Cr	A217-C12+13Cr	A351-CF8M
8	Gasket	Soft Steel	304SS	304 SS	304 SS	304 SS	304 SS
9	Packing	Graphite	Graphite	Graphite	Graphite	Graphite	Graphite
10	Gland Flange	A283 D	A283 D	A283 D	A283 D	A283 D	A351-CF8
11	Gland Bolt	A307 B	A307 B	A307 B	A307 B	A307 B	A193 B8
12	Gland Nut	A307 B	A307 B	A307 B	A307 B	A307 B	A194 8
13	Hinge Clamp Bolt	A193 B7	A193 B7	A193 B7	A193 B7	A193 B7	A193 B7
14	Packing Gland	C/S 1020+Cr	A479 410	A479 410	A479 410	A479 410	A479 316
15	Bonnet Bolt	A193 B7	A193 B16	A193 B16	A193 B16	A193 B16	A193 B8
16	Bonnet Nut	A194 2H	A194 4	A194 4	A194 4	A194 4	A194 8
17	Yoke Cap	C/S 1020	C/S 1020	C/S 1020	C/S 1020	C/S 1020	C/S 1020+Zn
18	Yock Sleeve	A439 D2	A439 D2	A439 D2	A439 D2	A439 D2	A439 D2
19	Handle Nut	C/S 1020	C/S 1020	C/S 1020	C/S 1020	C/S 1020	C/S 1020+Zn
20	Set Screw	C/S 1020	C/S 1020	C/S 1020	C/S 1020	C/S 1020	C/S 1020
21	Grease Nipple	Steel	Steel	Steel	Steel	Steel	Steel
22	Bearing	Steel	Steel	Steel	Steel	Steel	Steel
23	Yoke	A216-WCB	A216-WCB	A216-WCB	A216-WCB	A216-WCB	A351-CF8
24	Yoke Bolt	A193 B7	A193 B7	A193 B7	A193 B7	A193 B7	A193 B8
25	Yoke Nut	A194 2H	A194 2H	A194 2H	A194 2H	A194 2H	A194 8
27	Bonnet Clamp	C/S 1045	C/S 1045	C/S 1045	C/S 1045	C/S 1045	A240 304
28	Retainer	C/S 1045+Cr	A240 304	A240 304	A240 304	A240 304	A240 316
29	Adopter Ring	C/S 1045+Cr	A240 304	A240 304	A240 304	A240 304	A240 316
31	Bonnet Clamp	C/S 1045	C/S 1045	C/S 1045	C/S 1045	C/S 1045	A240 304
32	Washer	A479 410	A479 410	A479 410	A479 410	A479 410	A240 304
33	Hinge Clamp	A216-WCB	A216-WCB	A216-WCB	A216-WCB	A216-WCB	A351-CF8

### PRESSURE SEALED GATE VALVE

- Cast Steel Gate Valve, Outside Screw and York,
- Pressure Sealed, Rising Stem, Flexible Wedge
- "T" Head Stem
- Designed to ASME B16.34, API 600

Face to Face	ASME/ANSI B16.10
End Flange	ASME/ANSI B16.5
Buttweld	ASME/ANSI B16.25
Class	ASME/ANSI CL600-CL2500

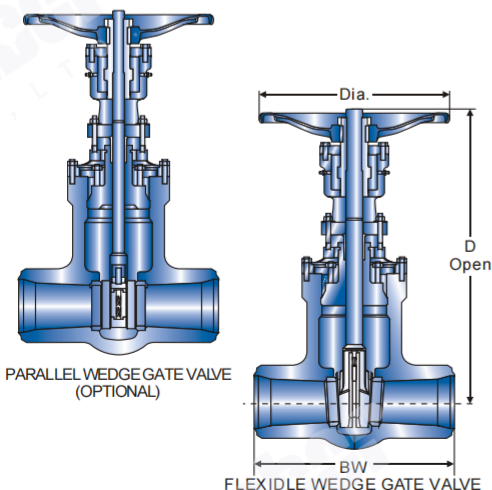

### CLASS 600 DIMENSION

SIZE(in.)	2-1/2	3	4	6	8	10	12	14	16	18	20	24	Unit: inch
A	8.50	10.00	12.00	18.00	23.00	28.00	32.0	35.00	39.00	43.00	47.00	55.00	
B	24	24	28	35	46	51	58	64	73	80	90	98	
E	10	10	14	14	20	24	30	30	34	34	34	38	
W.T(lbs)	71	75	145	295	535	905	1450	2120	2730	3200	4480	5432	

### CLASS 900 DIMENSION

SIZE(in.)	2	2-1/2	3	4	6	8	10	12	14	16	18	20	24	Unit: inch
A	8.50	10.00	12.00	14.00	20.00	26.00	31.00	36.00	39.00	43.00	48.00	52.00	55.00	
B	23	24	24	29	38	52	56	63	70	78	85	94	105	
E	10	10	10	18	18	20	24	30	30IHW	30IHW	30IHW	30IHW	38IHW	
W.T(lbs)	75	95	105	175	522	880	1270	1890	2630	3250	3985	5880	7925	

### CLASS 1500 DIMENSION

SIZE(in.)	2	2-1/2	3	4	6	8	10	12	14	16	18	20	24	Unit: inch
A	8.50	10.00	12.00	16.00	22.00	28.00	34.00	39.00	42.00	47.00	53.00	58.00	58.00	
B	23	24	24	29	39	53.50	58	65.50	73	80	87	95	105.5	
E	10	10	10	18	18	20	30	30IHW	30IHW	30IHW	30IHW	30IHW	38IHW	
W.T(lbs)	75	95	115	185	585	880	1905	3115	41.00	4850	6450	8820	11885	

### CLASS 2500 DIMENSION

SIZE(in.)	2-1/2	3	4	6	8	10	12	14	16	18	20	24	Unit: inch
A	13.00	14.50	18.00	24.00	30.00	36.00	41.00	44.00	49.00	55.00	62.00	66.00	
B	26	26	31	39	53	60	66	75	85	95	105	115	
E	18	18	20	20	30	30IHW	30IHW	30IHW	38IHW	38IHW	38IHW	38IHW	
W.T(lbs)	150	150	260	750	1250	2380	3650	4980	7275	8800	10585	13500	

I.H.W: IMPACTOR HANDWHEEL

## PRESSURE SEAL CAST STEEL GLOBE VALVES PARTS AND MATERIALS .CLASS 600, 900, 1500 & 2500

Item	Part Name	WCB	WC6	WC9	C5	C12	CF8M
1	Body	A216-WCB	A217-WC6	A217-WC9	A217-C5	A217-C12	A351-CF8M
2	Bonnet	A216-WCB	A217-WC6	A217-WC9	A217-C5	A217-C12	A351-CF8M
3	Disc	A216-WCB+HF	A217-WC6+HF	A217-WC9+HF	A217-C5+HF	A217-C12+HF	A351-CF8M+HF
4	Stem	A479410	A479410	A479410	A479410	A479410	A479316
5	Handwheel	A197 or WCB	A197 or WCB	A197 or WCB	A197 or WCB	A197 or WCB	A197 or WCB
6	Body seat Ring	A216-WCB+HF	A217-WC6+HF	A217-WC9+HF	A217-C5+HF	A217-C12+HF	A351-CF8M+HF
7	Backseat	A216-WCB+13Cr	A217-WC6+13Cr	A217-WC9+13Cr	A217-C5+13Cr	A217-C12+13Cr	A351-CF8M
8	Gasket	Soft Steel	304 SS	304 SS	304 SS	304 SS	316 SS
9	Packing	Graphite	Graphite	Graphite	Graphite	Graphite	Graphite
10	Gland Flange	A283 D	A283 D	A283 D	A283 D	A283 D	A351 B8
11	Gland Bolt	A307 B	A307 B	A307 B	A307 B	A307 B	A193 B8
12	Gland Nut	A307 B	A307 B	A307 B	A307 B	A307 B	A193 8
13	Packing Gland	C/S 1020+Cr	A479410	A479410	A479410	A479410	A479316
14	Bonnet Bolt	A193 B7	A193 B16	A193 B16	A193 B16	A193 B16	A193 B8
16	Bonnet Nut	A194 2H	A194 4	A194 4	A194 4	A194 4	A194 8
17	Yoke Cap	C/S 1020	C/S 1020	C/S 1020	C/S 1020	C/S 1020	C/S 1020+Cr
18	Yock Sleeve	A439 D2	A439 D2	A439 D2	A439 D2	A439 D2	A439 D2
19	Lock Nut	A479410	A479410	A479410	A479410	A479410	A479316
20	Disc Thrust Pad	A479410	A479410	A479410	A479410	A479410	A479410
21	Yoke	A216-WCB	A216-WCB	A216-WCB	A216-WCB	A216-WCB	A351-WCB
22*	Yoke Bolt	A193 B7	A193 B7	A193 B7	A193 B7	A193 B7	A193 B7
23*	Yoke Bolt Nut	A194 2H	A194 2H	A194 2H	A194 2H	A194 2H	A194 8
25*	Bonnet Clamp	C/S 1045	C/S 1045	C/S 1045	C/S 1045	C/S 1045	A240 304
26	Retainer	C/S 1045+Cr	A240 304	A204 304	A240 304	A240 304	A240 316
27	Adopter Ring	C/S 1045+Cr	C/S 1045	A204 304	A240 304	A240 304	A240 316
30	Handle Nut	C/S 1020	C/S 1020	C/S 1020	C/S 1020	C/S 1020	C/S 1020+Zn
34	Grease Nipple	Steel	Steel	Steel	Steel	Steel	Steel
35	Stopper	A216-WCB	A216-WCB	A216-WCB	A216-WCB	A216-WCB	A351-CF8
36	Stopper Bolt	A307 B	A307 B	A307 B	A307 B	A307 B	A193 B8
38	Set Screw	C/S 1020	C/S 1020	C/S 1020	C/S 1020	C/S 1020	C/S 1020
39	Bearing	Steel	Steel	Steel	Steel	Steel	Steel
40**	Bonnet Clamp	C/S 1045	C/S 1045	C/S 1045	C/S 1045	C/S 1045	A240 304
41**	Washer	A479410	A479410	A479410	A479410	A479410	A479316
42	Hinge Clamp	A216-WCB	A216-WCB	A216-WCB	A216-WCB	A216-WCB	A351-CF8
44	Gland Clamp Bolt	A307 B	A307 B	A307 B	A307 B	A307 B	A193 B8
45	Gland Clamp Nut	A307 B	A307 B	A307 B	A307 B	A307 B	A194 8

\*6" and above. \*\*4" and below. Note: HF reflects hardfaced with Stellite. For other materials, contact your salesperson.

### PRESSURE SEALED GLOBE VALVE

- Cast Steel Globe Valve, Outside Screw and York,
- Pressure Sealed, Rising Stem, Plug Disc
- Designed to ASME B16.34

Face to Face	ASME/ANSI B16.10
End Flange	ASME/ANSI B16.5
Buttweld	ASME/ANSI B16.25
Class	ASME/ANSI CL600~CL2500

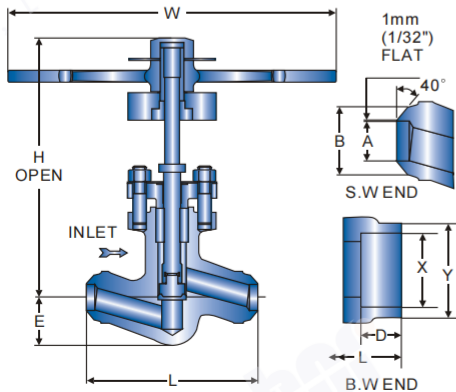

### CLASS 600~2500 DIMENSION

#### BUTT WELD END

SIZE (in.)	A	B	L	H	E	W	W.T.(lbs)
1/2	0.500	1.125	5.50	8.750	1.50	6	11
3/4	0.781	1.375	5.50	8.750	1.50	6	11
1	1.000	1.656	7.875	13.250	2.375	13	29
1 1/4	1.250	2.250	7.875	13.250	2.375	13	29
1 1/2	1.500	2.625	9.875	14.750	2.750	21	44
2	1.844	3.375	11.812	16.500	3.563	26.750	110

Unit: inch

### CLASS 600~2500 DIMENSION

#### SOCKET WELD END

SIZE (in.)	X	Y	L	H	E	W	W.T.(lbs)
1/2	1.750	0.855	5.50	8.750	1.50	6	11
3/4	1.750	1.065	5.50	8.750	1.50	6	11
1	2.562	1.330	7.875	13.250	2.375	13	29
1 1/4	2.562	1.675	7.875	13.250	2.375	13	29
1 1/2	2.937	1.915	9.875	14.750	2.750	21	44
2	4.125	2.406	11.812	16.500	3.563	26.750	110

Unit: inch



# Gate, Globe, Check Valve

## PRESSURE SEALED GLOBE VALVE

- Cast Steel Globe Valve, Outside Screw and York,
- Pressure Sealed, Rising Stem, Plug Disc
- Designed to ASME B16.34

Face to Face	ASME/ANSI B16.10
End Flange	ASME/ANSI B16.5
Buttweld	ASME/ANSI B16.25
Class	ASME/ANSI CL600~CL2500

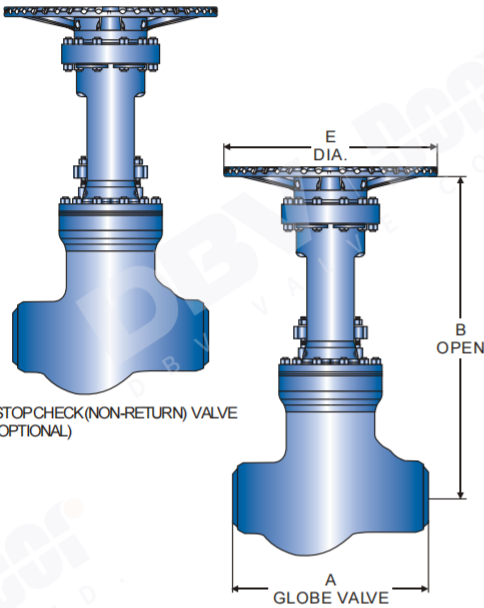

## CLASS 600 DIMENSION

SIZE (in.)	2-1/2	3	4	6	8	10	12	14	16	18	20	24
A	8.50	10.00	12.00	18.00	23.00	28.00	32.0	35.00	39.00	43.00	47.00	55.00
B	23	25	28	33.50	44	49	53	62	70	78	85	98
E	12	12	14	18	20	24	30	30	34	34	38	30IHW
W.T (lbs)	71	75	135	285	520	885	1425	1780	2640	3100	4200	5200

## CLASS 900 DIMENSION

SIZE (in.)	2	2-1/2	3	4	6	8	10	12	14	16	18	20	24
A	8.50	10.00	12.00	14.00	20.00	26.00	31.00	36.00	39.00	43.00	48.00	52.00	55.00
B	23	24	28	31	37	46	51	55	65	76	80	88	95
E	12	14	14	18	20	24	30	30IHW	30IHW	30IHW	38IHW	38IHW	38IHW
W.T (lbs)	70	95	105	160	430	850	1200	1850	2625	3130	3800	4600	6400

## CLASS 1500 DIMENSION

SIZE (in.)	2	2-1/2	3	4	6	8	10	12	14	16	18	20	24
A	8.50	10.00	12.00	16.00	22.00	28.00	34.00	39.00	42.00	47.00	53.00	58.00	58.00
B	23	24	28	31	37	47	52	58	65	75	80	88	95
E	12	14	14	18	20	24	30	30IHW	30IHW	38IHW	38IHW	38IHW	38IHW
W.T (lbs)	70	95	105	160	450	880	1750	2650	38.00	4730	5800	7900	10200

## CLASS 2500 DIMENSION

SIZE (in.)	2	2-1/2	3	4	6	8	10	12	14	16	18	20	24
A	11	13.00	14.50	18.00	24.00	30.00	36.00	41.00	44.00	49.00	55.00	58.00	58.00
B	24	26	26	33	39	51	53	61	70	79	87	96	105
E	14	18	18	20	24	30	30IHW	30IHW	30IHW	38IHW	38IHW	38IHW	38IHW
W.T (lbs)	130	140	150	235	530	1150	1980	3140	4730	6650	7400	9800	12900

[H.W: IMPACTORHANDWHEEL

## Y PATTERN PRESSURE SEALED GLOBE VALVE

- Cast Steel Globe Valve, YPattern,
- Outside Screw and York, Rising Stem
- Pressure Sealed, Plug Disc
- Designed to ASME B16.34, BS1873

Face to Face	ASME/ANSI B16.10
End Flange	ASME/ANSI B16.5
Buttweld	ASME/ANSI B16.25
Class	ASME/ANSI CL900~CL2500

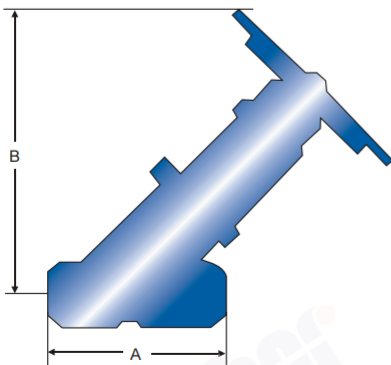

## CLASS 900/1500 DIMENSION

SIZE (in.)	2-1/2	3	4	6	8	10	12	14	16	18	20	24
A	14.50	14.50	16.00	27.75	30.00	36.25	43.00	43.00	54.00	58.00	55.00	59.50
B	25.25	25.25	25.25	37.00	46.00	50.00	60.00	60.00	74.00	74.00	78.00	95.00
W.T (lbs)	225	225	275	800	1750	2375	3375	3375	7500	7500	10000	13600

## CLASS 2500 DIMENSION

SIZE (in.)	2-1/2	3	4	6	8	10	12	14	16	18	20
A	14.50	14.50	18.00	24.00	30.00	36.00	41.00	48.75	48.75	58.00	58.00
B	25.25	25.25	25.25	39.00	45.00	50.00	55.00	55.00	61.00	78.00	78.00
W.T (lbs)	225	225	275	935	1800	3000	5100	5100	7000	12000	12000

**PRESSURE SEAL CAST STEEL CHECK VALVES**

**PARTS AND MATERIALS . CLASS 600, 900, 1500 & 2500**

Item	Part Name	WCB	WC6	WC9	C5	C12	CF8M
1	Body	A216-WCB	A217-WC6	A217-WC9	A217-C5	A217-C12	A351-CF8M
2	Bonnet	A216-WCB	A217-WC6	A217-WC9	A217-C5	A217-C12	A351-CF8M
3	Disc	A216-WCB+HF	A217-WC6+HF	A217-WC9+HF	A217-C5+HF	A217-C12+HF	A351-CF8M+HF
4	Arm	A479-410	A217WC6	A217WC9	A217 C5	A217 C12	A351CF8M
5	Rod Pin	A395	A479410	A479410	A479410	A479410	A479316
6	Body Seat Ring	C/S	A182F11+HF	A182 F22+HF	A182F5a+HF	A182 F9+HF	A240316+HF
7	Plug Bolt	A479410	A479304	A479304	A479304	A479304	A479316
8	Gasket	Soft Steel	304 SS	304 SS	304 SS	304 SS	316 SS
9	Plug Gasket	Soft Steel	304 SS	304 SS	304 SS	304 SS	316 SS
10	Bonnet Bolt	A193B7	A193B16	A193B16	A193B16	A193B16	A193B8
11	Bonnet Nut	A1942H	A1944	A1944	A1944	A1944	A1948
12	Disc Nut	A1948	A1948	A1948	A1948	A1948	A1948M
13	Split Pin	A580304	A580304	A580304	A580304	A580304	A580316
14	Washer	A240304	A240304	A240304	A240304	A240304	A240316
15	Bonnet Clamp	C/S 1045	C/S 1045	C/S 1045	C/S 1045	C/S 1045	A240304
16	Retainer	C/S 1045+H.F	A240304	A240304	A240304	A240304	A240316
17	Adapter Ring	C/S 1045+H.F	A240304	A240304	A240304	A240304	A240316
18	Sealing Bolt	A479410	A479410	A479410	A479410	A479410	A479316
19	Sealing Nut	A1942H	A1942H	A1942H	A1942H	A1942H	A1948
20	Eye Bolt	A105	A105	A105	A105	A105	A105
21	Nut	A1942H	A1942H	A1942H	A1942H	A1942H	A1948
22	Washer	A283D	A283D	A283D	A283D	A283D	A350CF8

Other materials available upon request to meet specific service requirements.

**PRESSURE SEALED SWING CHECK VALVE**

- Cast Steel Check Valve
- Swing Type, Pressure Sealed
- Horizontal or Vertical Lines
- Designed to API6D, BS1868

Face to Face	ASME/ANSI B16.10
End Flange	ASME/ANSI B16.5
Buttweld	ASME/ANSI B16.25
Class	ASME/ANSI CL900~CL2500

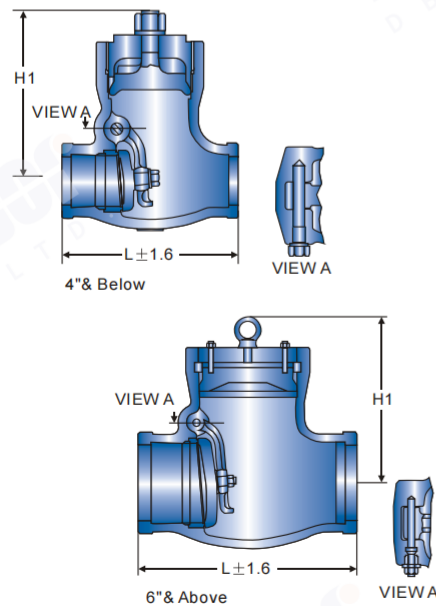

**CLASS 600 DIMENSION**

SIZE (in.)	2	3	4	6	8	10	12	14	16	18	20	24
L	7.00	10.00	12.00	18.00	23.00	28.00	32.00	35.00	39.00	43.00	47.00	55.00
H	7.52	9.76	12.13	14.37	16.14	18.31	20.08	22.09	24.33	26.50	38.74	30.94
Cv	123	284	519	1243	2213	3397	5120	8384	8344	10508	13745	18751
W.T(lbs)	80	100	125	287	573	815	1081	1455	1874	2425	3285	4498

**CLASS 900 DIMENSION**

SIZE (in.)	2	3	4	6	8	10	12	14	16	18	20	24
L	8.50	12.00	14.00	20.00	26.00	31.00	36.00	39.00	43.00	48.00	52.00	61.00
H	9.57	9.53	14.57	15.75	21.06	21.06	24.02	26.97	32.64	32.64	35.35	38.31
Cv	107	260	486	1142	2010	3138	4586	5565	9575	9575	11821	17023
W.T(lbs)	90	198	243	540	937	1521	2249	2690	2976	4079	5292	6395

**CLASS 1500 DIMENSION**

SIZE (in.)	2	3	4	6	8	10	12	14	16	18	20	24
L	8.50	12.00	16.00	22.00	28.00	34.00	39.00	42.00	47.00	60.50	65.50	76.50
H	9.57	11.81	14.29	15.91	16.10	22.64	26.85	29.61	31.57	34.53	36.89	40.63
Cv	107	238	425	996	1751	2736	3988	4794	6268	8251	10344	14859
W.T(lbs)	90	154	254	551	1036	1632	2425	3110	3528	4630	5733	7718

**CLASS 2500 DIMENSION**

SIZE (in.)	2	3	4	6	8	10	12	14	16	18	20	24
L	11.00	14.50	18.00	24.00	30.00	36.00	41.00	44.00	48.00	53.00	57.00	66.00
H	10.24	13.78	15.94	17.91	22.44	24.88	32.09	30.55	33.70	36.14	38.82	43.22
Cv	69	160	267	660	1182	1878	2756	3347	4382	5793	7035	10193
W.T(lbs)	110	187	364	1015	1985	2866	3969	5402	7056	8930		

# Gate, Globe, Check Valve

## PRESSURE SEALED PISTON CHECK VALVE

- Cast Steel Check Valve Valve
- Lift Piston, Pressure Sealed
- Horizontal or Vertical Lines
- Designed to API6D, BS1868

Face to Face	ASME/ANSI B16.10
End Flange	ASME/ANSI B16.5
Buttweld	ASME/ANSI B16.25
Class	ASME/ANSI CL600~CL2500

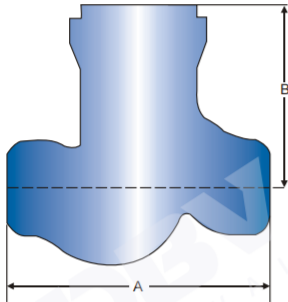

## PRESSURE SEALED Y PATTERN CHECK VALVE

- Cast Steel Check Valve Valve
- Lift Piston, Pressure Sealed
- Horizontal or Vertical Lines
- Designed to API6D, BS1868

Face to Face	ASME/ANSI B16.10
End Flange	ASME/ANSI B16.5
Buttweld	ASME/ANSI B16.25
Class	ASME/ANSI CL900~CL2500

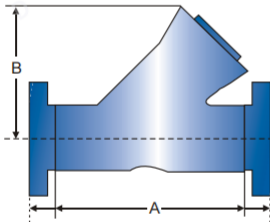

## PRESSURE SEALED TILTING DISC CHECK VALVE

- Cast Steel Tilting Disc Check Valve
- Pressure Sealed
- Horizontal or Vertical Lines
- Designed to API6D, BS1868

Face to Face	ASME/ANSI B16.10
End Flange	ASME/ANSI B16.5
Buttweld	ASME/ANSI B16.25
Class	ASME/ANSI CL900~CL2500

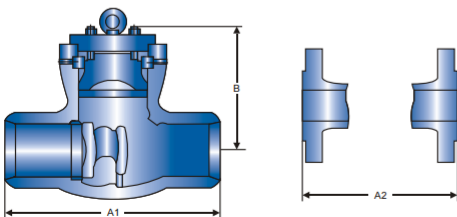

## CLASS 600 DIMENSION

SIZE(in.)	2-1/2	3	4	6	8	10	12	14	16	18	20	24
A	8.50	10.00	12.00	18.00	23.00	28.00	32.00	35.00	39.00	43.00	47.00	55.00
B	8.5	8.5	9.5	10.5	13	17	19	20	21.5	26	28	33
W.T(lbs)	71	75	125	260	490	780	1245	-	-	-	-	-

## CLASS 900 DIMENSION

SIZE(in.)	2-1/2	3	4	6	8	10	12	14	16	18	20	24
A	10.00	12.00	14.00	20.00	26.00	31.00	36.00	39.00	43.00	48.00	52.00	61.00
B	8	8	10	12	15	18	20	22	24	27	31	35
W.T(lbs)	85	90	155	370	685	1235	1780	-	-	-	-	-

## CLASS 1500 DIMENSION

SIZE(in.)	2-1/2	3	4	6	8	10	12	14	16	18	20	24
A	10.00	12.00	16.00	22.00	28.00	34.00	39.00	42.00	47.00	52.00	56.00	58.00
B	8	9	10	12	15	18	21	23	25	29	32	37
W.T(lbs)	85	90	160	380	720	1380	1975	-	-	-	-	-

## CLASS 2500 DIMENSION

SIZE(in.)	2-1/2	3	4	6	8	10	12	14	16	18	20	24
A	13.00	14.50	18.00	24.00	30.00	36.00	41.00	44.00	48.00	53.00	56.00	58.00
B	9.5	9.5	21.5	14	17	20	23	25.5	28	31	34	38
W.T(lbs)	120	125	190	480	830	1400	2320	-	-	-	-	-

## CLASS 900/1500 DIMENSION

SIZE(in.)	2-1/2	2-1/2	4	6	8	10	12	14	16	18	20	24
A	14.50	14.50	16.00	27.75	30.00	36.25	43.00	43.00	54.00	58.00	55.00	59.50
B	10.50	10.50	10.50	16.00	20.75	25.50	29.75	39.75	40.25	43.00	43.25	48.00
W.T(lbs)	160	160	190	540	1240	1700	2400	2400	5300	5500	7200	9750

## CLASS 2500 DIMENSION

SIZE(in.)	2-1/2	3	4	6	8	10	12	14	16	18	20
A	14.50	14.50	18.00	24.00	30.00	36.00	41.00	48.75	48.75	58.00	58.00
B	10.50	10.50	10.50	16.00	20.75	25.50	29.75	34.75	34.50	43.00	37.38
W.T(lbs)	160	160	200	650	1300	2100	3300	3500	4850	8400	8700

## FLOW COEFFICIENCY Cv

SIZE(in.)	2	2-1/2	3	4	6	8	10	12	14	16	18	20	24
CLASS 900/1500	80	90	110	120	650	1300	2050	2300	2800	4850	4850	6300	9000
CLASS 2500	80	90	110	110	490	870	1425	2050	2250	3000	3250	4850	6300

## CLASS 900 DIMENSION

SIZE(in.)	2	2-1/2	3	4	6	8	10	12	14	16
A1(B.W)	8.5	10	12	14	20	26	31	36	39	43
A2(R.F)	14.5	16.5	15	18	24	29	33	38	40.5	44.5
B	9	10.3	8.1	11	13.3	15.6	17.9	21.3	23	26
W.T RF	54	70	88	118	230	550	850	1220	1690	2710
(kg) BW	30	46	49	93	160	390	600	900	1200	1600

## CLASS 1500 DIMENSION

SIZE(in.)	2	2-1/2	3	4	6	8	10	12
A1(B.W)	8.5	10	12	16	22	28	34	39
A2(R.F)	14.5	16.5	18.5	21.5	27.75	32.75	39	44.5
B	9	10.3	8.1	11	13.3	15.6	17.9	21.3
W.T RF	54	70	105	178	392	600	980	1550
(kg) BW	30	46	65	135	280	480	780	1100

## CLASS 2500 DIMENSION

SIZE(in.)	2	2-1/2	3	4	6	8	10
A1(B.W)	11	13	14.5	18	24	30	36
A2(R.F)	17.75	20	22.75	26.5	36	40.25	50
B	9	10.3	10.6	11	13.5	19	22
W.T RF	85	115	155	265	585	985	1600
(kg) BW	58	70	85	145	330	780	1220

## TYPICAL DBV FORGED STEEL GATE VALVE EXPANDED VIEW

1. Handwheel Nut: The handwheel nut secures the handwheel to the bonnet assembly.
2. Handwheel: The handwheel cycles the valve.
3. Stem Nut: The stem nut provides a precision guide for proper stem alignment.
- 4 & 11. Gland Bolts & Nuts: The gland bolt and nut allows for easy adjustments for packing compression.
5. Stuffing Box: The stuffing box contains the packing.
6. Bonnet Bolts: The bonnet bolts secure the bonnet to the body.
7. Yoke & Bonnet: DBV bonnet assemblies are built to the same standards as the bodies. Larger size gate valves utilize a multi-piece bonnet design.
8. Bonnet Gasket: The bonnet gasket creates a leakproof seal between the bonnet and body.
9. Body: DBV forged steel bodies provide low resistance flow and optimum strength and performance.
10. Seat Rings: To ensure a stable shutoff, seat rings are aligned and swaged into the valve, then precision ground for optimal seating.
12. Gland Flange: Applies pressure to the gland for accurate packing adjustments.
13. Gland: Compresses the packing to create a stem seal above the back seat, between the bonnet and stem.
14. Packing: The packing creates a seal above the back seat, between the bonnet and stem.
15. Stem: The stem is precision machined and inserts into the horizontal channel in the disc.
16. Wedge: DBV solid wedge is machined to the tightest tolerances to ensure trouble-free shutoff and cycling.

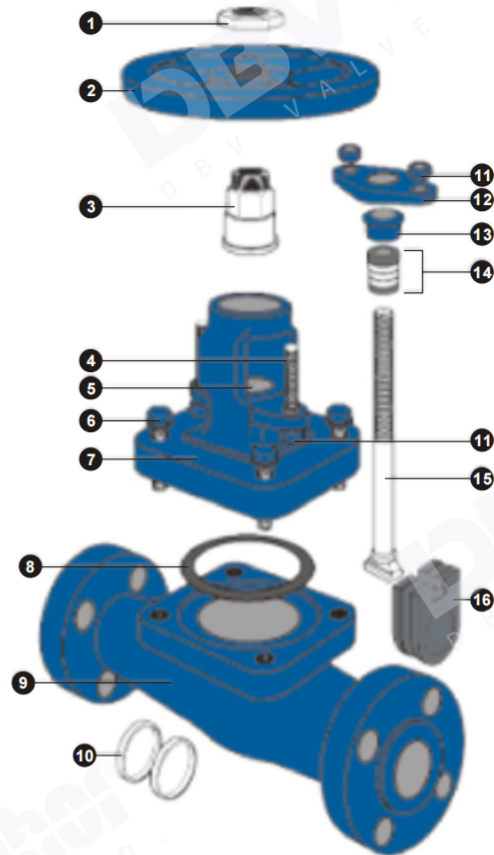

## BOLTED, WELDED & UNION BONNET • CLASS 150, 300, 600, 800, 1500, & 2500

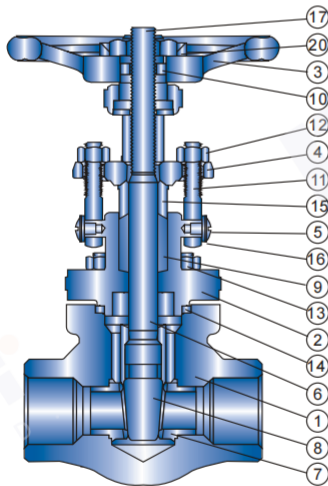

No.	Part	Material
1	Body	Carbon Steel, ASTM A105N
2	Bonnet	Carbon Steel, ASTM A105N
3	handwheel	Carbon Steel
4	Gland Flange	Carbon Steel, ASTM A105
5	Eyebolt Screws	Zinc Plated, Carbon Steel
6	Stem	Alloy Steel, ASTM A182 F6
7	Seats	Alloy Steel, ASTM A182 F6/Stellite 6
8	Wedge	Alloy Steel, ASTM A182 F6
9	Packing	Graphite Stack
10	Yoke Nut	Stainless Steel, AISI 416
11	Eyebolts	Stainless Steel, ASTM A193-B8
12	Eyebolt Nuts	Carbon Steel, ASTM A194 2HM
13	Cap Screws	Alloy Steel, ASTM A193 B7M
14	Gasket	316 SS Spiral Wound Grafoil
15	Packing Gland	Stainless Steel, AISI 416
16	Lock Nut Washer	Stainless Steel
17	Handwheel Nut	Carbon Steel
20	Name Plate	Stainless Steel

## DBV FORGED VALVES ARE MANUFACTURED IN STRICT ACCORDANCE WITH THE FOLLOWING STANDARDS:

API602	Compact steel gate valves
API598	Valve Inspection and Test
ANSI/ASME B16.34	Steel valve, flanged and butt-welding end
ANSI/ASME B16.5	Steel pipe flanges and flanged fittings
ANSI/ASME B16.10	Face-to-face and end-to-end dimensions of ferrous valves
ANSI/ASME B 16.11	Forged steel fittings, socket welding and threaded
ANSI/ASME B 1.20.1	Pipe threads, general purpose
ANSI/ASME B31.3	Chemical plant and petroleum refinery piping
MSS-SP-25	Standard marking system for valves, fittings, flanges and unions
MSS-SP-6	Standard finishes for contact faces of pipe, flanges and connecting end flanges of valves and fittings
NACE MR-01-75	Material requirements: Sulfide stress cracking resistant metallic materials for oil field equipment.

# Gate, Globe, Check Valve

## FORGED STEEL GATE VALVE

- Forged Steel Gate Valve, Outside Screw and York,
- Bolted, Welded & Union Bonnet, Rising Stem
- Threaded, Socketed, Buttwelded Ends
- Conventional Ports
- Designed to API 602

Face to Face	DBV Standard
Pipe Threads, G.P	ASME B1.20.1
Threaded Ends	ASME B16.11
Buttweld	ASME B16.25
Class	ASME CL800~CL2500

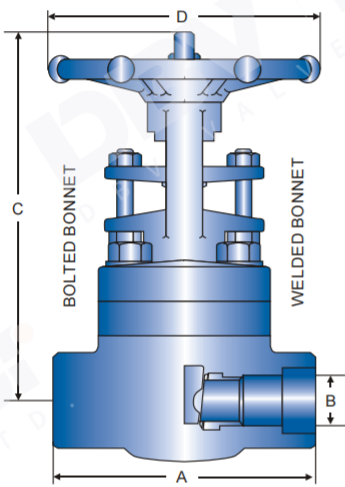

### CLASS 800 DIMENSION CLASS 800 WB

SIZE (in.)	A	B	C	D	W.T (lbs)
	Unit:inch				
1/4	3.1	0.31	5.7	3.1	3.5
3/8	3.1	0.39	5.7	3.1	3.5
1/2	3.2	0.39	5.2	3.2	3.2
3/4	3.5	0.55	5.4	3.2	4.4
1	4.3	0.71	6.3	3.9	7.1
1-1/4	5.0	0.95	7.4	4.7	10.7
1-1/2	5.0	1.22	8.4	5.5	14.3
2	5.1	1.44	8.9	5.5	18.7
3	-	-	-	-	-

### CLASS 800 DIMENSION CLASS 800 BB

SIZE (in.)	A	B	C	D	W.T (lbs)
	Unit:inch				
1/4	3.1	0.31	5.7	3.1	3.9
3/8	3.1	0.39	5.7	3.1	3.9
1/2	3.2	0.39	5.2	3.2	3.9
3/4	3.5	0.55	5.4	3.2	4.6
1	4.3	0.71	6.3	3.9	7.9
1-1/4	5.0	0.95	7.4	4.7	11.2
1-1/2	5.0	1.22	8.4	5.5	15.4
2	5.1	1.44	8.9	5.5	20.0
3	7.3	2.13	15.5	11.3	56

### CLASS 1500 DIMENSION CLASS 1500 WB

SIZE (in.)	A	B	C	D	W.T (lbs)
	Unit:inch				
1/2	3.5	0.39	5.4	3.2	5.0
3/4	4.3	0.55	6.4	3.9	8.4
1	4.7	0.75	7.5	4.7	12.6
1-1/4	5.1	0.95	8.3	5.5	14.6
1-1/2	5.1	1.16	9	5.5	22.0
2	5.9	1.44	10.2	6.7	33.0

### CLASS 1500 DIMENSION CLASS 1500 BB

SIZE (in.)	A	B	C	D	W.T (lbs)
	Unit:inch				
1/2	3.5	0.39	5.4	3.2	5.5
3/4	4.3	0.55	6.4	3.9	8.4
1	4.7	0.75	7.5	4.7	11.9
1-1/4	5.1	0.95	8.3	5.5	17.6
1-1/2	5.1	1.16	9	5.5	22.4
2	5.9	1.44	10.2	6.7	33.0

### CLASS 2500 DIMENSION CLASS 2500 WB

SIZE (in.)	A	B	C	D	W.T (lbs)
	Unit:inch				
1/2	4.3	0.39	6.9	3.9	7.7
3/4	4.7	0.55	8.3	4.7	12.1
1	5.1	0.75	9.4	5.5	16.5
1-1/4	5.1	0.95	11.0	6.7	22
1-1/2	8.3	1.16	12.2	6.7	35.2
2	9.4	1.44	14	10.2	55

### CLASS 2500 DIMENSION CLASS 2500 BB

SIZE (in.)	A	B	C	D	W.T (lbs)
	Unit:inch				
1/2	4.3	0.39	8.3	3.9	12.1
3/4	4.7	0.55	10.0	4.7	18.7
1	5.1	0.75	10.4	5.5	22.4
1-1/4	5.1	0.95	14.4	6.7	57.2
1-1/2	8.3	1.16	14.8	6.7	57.2
2	9.4	1.44	15.4	10.2	81.4

## FORGED STEEL FLANGED GATE VALVE

- Forged Steel Gate Valve, Outside Screw and York,
- Bolted, Welded & Union Bonnet, Rising Stem
- Flanged Ends, Conventional Ports
- Designed to API 602

Face to Face	ASME/ANSI B16.10
Pipe Threads, G.P	ASME B1.20.1
Threaded Ends	ASME B16.11
Buttweld	ASME B16.25
Class	ASME CL150~CL1500

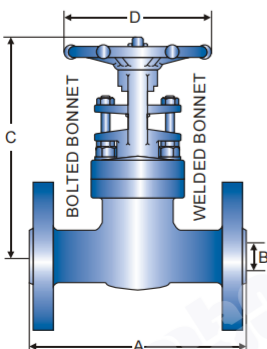

### CLASS 150 DIMENSION CLASS 150 BB & WB

SIZE (in.)	A	B	C	D	W.T (lbs)
	Unit:inch				
1/2	4.3	0.39	6.3	3.2	6.8
3/4	4.6	0.55	6.5	3.2	8.6
1	5.0	0.71	7.2	4.0	12.1
1-1/4	5.5	0.94	7.7	4.8	18.1
1-1/2	6.5	1.22	8.3	5.5	23.4
2	7.0	1.44	9.8	5.5	32.0

### CLASS 300 DIMENSION CLASS 300 BB & WB

SIZE (in.)	A	B	C	D	W.T (lbs)
	Unit:inch				
1/2	5.5	0.39	5.2	3.2	7.3
3/4	6.0	0.55	5.4	3.2	10.8
1	6.5	0.71	6.3	3.9	14.7
1-1/4	7.0	0.94	7.5	4.7	21.1
1-1/2	7.5	1.22	9.0	5.5	29.5
2	8.5	1.44	9.5	6.7	35.9

### CLASS 600 DIMENSION CLASS 600 BB & WB

SIZE (in.)	A	B	C	D	W.T (lbs)
	Unit:inch				
1/2	6.5	0.39	7.0	3.2	7.7
3/4	7.5	0.55	7.3	3.2	11.7
1	8.5	0.71	6.3	4.0	15.7
1-1/4	9.0	0.94	9.8	5.5	30.9
1-1/2	9.5	1.22	10.0	5.5	30.9
2	11.5	1.44	11.0	5.6	40.8

### CLASS 1500 DIMENSION CLASS 1500 BB & WB

SIZE (in.)	A	B	C	D	W.T (lbs)
	Unit:inch				
1/2	8.5	0.55	7.8	3.9	22
3/4	9	0.55	7.8	4.7	33
1	10	0.71	8.6	5.5	37.4
1-1/4	-	0.95	9.3	-	-
1-1/2	12	1.14	10.8	6.8	77
2	14.5	1.44	12.6	10.2	121

**FORGED STEEL EXTENDED BODY GATE VALVE**

Forged Steel Gate Valve, Outside Screw and York, Bolted, Welded & Union Bonnet, Rising Stem Lip, Threaded, Contoured, Socket Weld Ends Extended Body, Conventional Ports Designed to API 602

Face to Face	DBV Standard
Pipe Threads, G.P	ASME B1.20.1
Threaded Ends	ASME B16.11
Buttweld	ASME B16.25
Class	ASME CL800

**AVAILABLE ENDS**

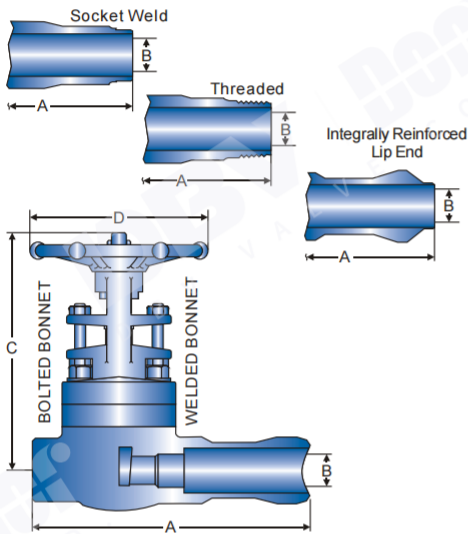

**CLASS 800 DIMENSION CLASS 800 IR CONTOURED END**

SIZE (in.)	A	B	C	D	W.T (lbs)
	Unit: inch				
1/2	8.6	0.39	5.9	3.2	6
3/4	8.6	0.55	6.1	3.2	7
1	9.6	0.71	7.3	3.9	10
1-1/2	10.4	1.14	10.2	5.5	19
2	11.4	1.44	10.8	5.5	29

**CLASS 800 DIMENSION CLASS 800 IR - LIP END**

SIZE (in.)	A	B	C	D	W.T (lbs)
	Unit: inch				
1/2	8.6	0.39	5.9	3.2	6
3/4	8.6	0.55	6.1	3.2	7
1	9.6	0.71	7.3	3.9	10
1-1/2	10.4	1.14	10.2	5.5	19
2	11.4	1.44	10.8	5.5	29

**CLASS 800 DIMENSION CLASS 800 THREADED**

SIZE (in.)	A	B	C	D	W.T (lbs)
	Unit: inch				
1/2	5.6	0.39	6.4	3.1	5.7
3/4	5.8	0.55	7.3	3.9	6.4
1	6.5	0.7	7.6	3.9	9.5
1-1/2	7.5	1.14	10	5.5	19.4
2	8.5	1.44	10.7	6.7	28.6

**CLASS 800 DIMENSION CLASS 800 SOCKET WELD**

SIZE (in.)	A	B	C	D	W.T (lbs)
	Unit: inch				
1/2	5.6	0.39	6.4	3.1	5.7
3/4	5.8	0.55	7.3	3.9	6.4
1	6.5	0.7	7.6	3.9	9.5
1-1/2	7.5	1.14	10	5.5	19.4
2	8.5	1.44	10.7	6.7	28.6

**FORGED STEEL EXTENDED BODY GATE VALVE**

Forged Steel Gate Valve, Outside Screw and York, Bolted, Welded & Union Bonnet, Rising Stem Lip, Threaded, Contoured, Socket Weld Ends Extended Body, Conventional Ports Designed to API 602

Face to Face	DBV Standard
Pipe Threads, G.P	ASME B1.20.1
Threaded Ends	ASME B16.11
Buttweld	ASME B16.25
Class	ASME CL1500

**AVAILABLE ENDS**

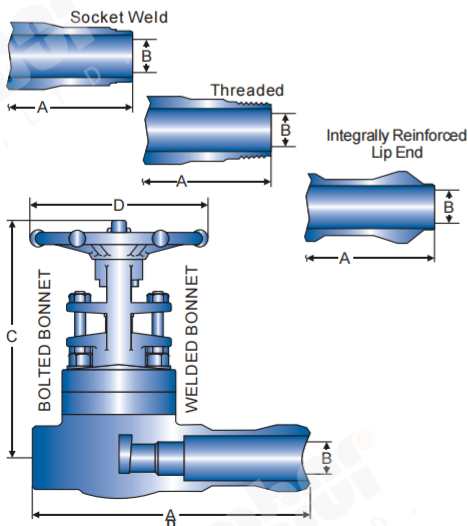

**CLASS 1500 DIMENSION CLASS 1500 RE-OUT-FORCED**

SIZE (in.)	A	B	C	D	W.T (lbs)
	Unit: inch				
1/2	8.6	0.39	5.4	3.2	6
3/4	9.6	0.55	6.3	3.9	10
1	10.4	0.75	8.6	4.7	15
1-1/2	10.5	1.16	9.4	5.5	25
2	12.8	1.44	10.9	6.7	35

**CLASS 1500 DIMENSION CLASS 1500 RE-IN FORCED**

SIZE (in.)	A	B	C	D	W.T (lbs)
	Unit: inch				
1/2	8.6	0.39	5.4	3.2	6
3/4	9.6	0.55	6.3	3.9	10
1	10.4	0.75	8.6	4.7	15
1-1/2	10.5	1.16	9.4	5.5	25
2	12.8	1.44	10.9	6.7	35

**CLASS 1500 DIMENSION CLASS 1500 THREADED**

SIZE (in.)	A	B	C	D	W.T (lbs)
	Unit: inch				
1/2	5.7	0.39	6.5	3.2	6.4
3/4	6.5	0.55	7.1	3.9	9.5
1	7.5	0.7	9.4	5.5	19.4
1-1/2	8.5	1.14	10.6	6.7	29.7
2	9.8	1.44	12.6	10.2	41.1

**CLASS 1500 DIMENSION CLASS 1500 SOCKET WELD**

SIZE (in.)	A	B	C	D	W.T (lbs)
	Unit: inch				
1/2	5.7	0.39	6.5	3.2	6.4
3/4	6.5	0.55	7.1	3.9	9.5
1	7.5	0.7	9.4	5.5	19.4
1-1/2	8.5	1.14	10.6	6.7	29.7
2	9.8	1.44	12.6	10.2	41.1

# Gate, Globe, Check Valve

## DBV FORGED STEEL GLOBE VALVE EXPANDED VIEW

1. Handwheel Nut: The handwheel nut secures the handwheel to the bonnet assembly.
2. Handwheel Washer: The washer helps to prevent loosening.
3. Handwheel: The handwheel cycles the valve.
- 4 & 14. Gland Bolts & Nuts: The gland bolt and nut allows for easy adjustments for packing compression.
5. Gland Flange: Applies pressure to the gland for accurate packing compression.
6. Gland: Compresses the packing to create a stem seal above the back seat, between the bonnet and stem.
7. Packing: The packing creates a seal above the back seat, between the bonnet and stem.
8. Bonnet Bolts: The bonnet bolts secure the bonnet to the body.
9. Bonnet: DBV bonnet assemblies are built to the same standards as the bodies.
10. Bonnet Gasket: The bonnet gasket creates a leakproof seal between the bonnet and body.
11. Body: DBV forged steel bodies provide low resistance flow and optimum strength and performance.
12. Seat Ring: To ensure a stable shutoff, the seat ring is aligned into the valve, then precision ground for optimal seating.
13. Stem Nut: The stem nut provides a precision guide for proper stem alignment.
14. Stuffing Box: The stuffing box contains the packing.
16. Stem: The stem inserts vertically into the disc.
17. Lock Groove: The lock groove receives the split lock ring which allows the disc nut to lift the disc during cycling.
18. Disc Nut: The disc nut, in conjunction with the split lock ring, secures the disc to the stem.
19. Split Ring: The split ring allows the disc nut to lift the disc during cycling.
20. Disc: DBV plug type disc is machined to the tightest tolerances to ensure trouble free shutoff and cycling.

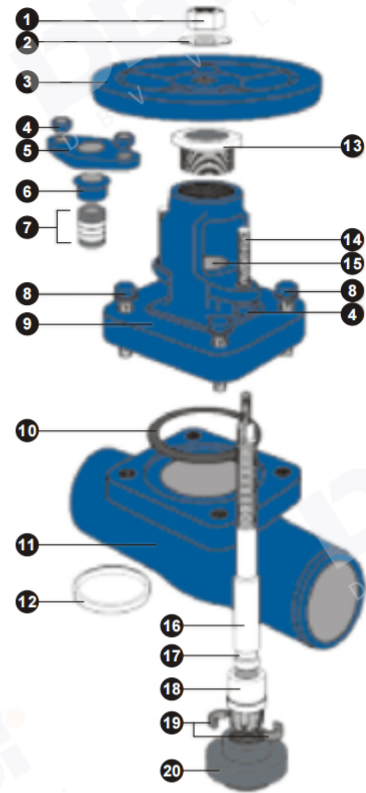

## BOLTED & WELDED BONNET • CLASS 150, 300, 600, 800, 1500 & 2500

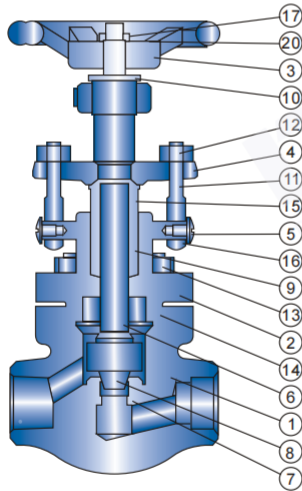

No.	Part	Material
1	Body	ASTM A105N Carbon Steel
2	Bonnet	ASTM A105N Carbon Steel
3	Handwheel	Carbon Steel
4	Gland Flange	ASTM A105 Carbon Steel
5	Eyebolt Screws	Zinc Plated Carbon Steel
6	Stem	ASTM A182 F6 Alloy Steel
7	Seat	ASTM S182 F6/Stellite 6 Facing
8	Disc	ASTM A182 F6 Alloy Steel
9	Packing	Graphite Stack
10	Yoke Nut	AISI Type 416 Stainless Steel
11	Eyebolts	ASTM A193 B8 Stainless Steel
12	Eyebolt Nuts	ASTM A194 2HM Carbon Steel
13	Cap Screws	ASTM A193 B7M Alloy Steel
14	Gasket	316 SS Spiral Wound Grafoil
15	Packing Gland	AISI Type 416 Stainless Steel
16	Lock Nut Washer	Stainless Steel
17	Handwheel Nut	Carbon Steel
20	Name Plate	Stainless Steel

## DBV FORGED VALVES ARE MANUFACTURED IN STRICT ACCORDANCE WITH THE FOLLOWING STANDARDS:

API602	Compact steel gate valves
API598	Valve Inspection and Test
ANSI/ASME B16.34	Steel valve, flanged and butt-welding end
ANSI/ASME B16.5	Steel pipe flanges and flanged fittings
ANSI/ASME B16.10	Face-to-face and end-to-end dimensions of ferrous valves
ANSI/ASME B 16.11	Forged steel fittings, socket welding and threaded
ANSI/ASME B 1.20.1	Pipe threads, general purpose
ANSI/ASME B31.3	Chemical plant and petroleum refinery piping
MSS-SP-25	Standard marking system for valves, fittings, flanges and unions
MSS-SP-6	Standard finishes for contact faces of pipe, flanges and connecting end flanges of valves and fittings
NACE MR-01-75	Material requirements: Sulfide stress cracking resistant metallic materials for oil field equipment.

**FORGED STEEL GLOBE VALVE**

- Forged Steel Globe Valve, Outside Screw and York,
- Bolted, Welded & Union Bonnet, Rising Stem
- Threaded, Socketed, Buttwelded Ends
- Conventional Ports
- Designed to API 602

Face to Face	DBV Standard
Pipe Threads, G.P	ASME B1.20.1
Threaded Ends	ASME B16.11
Buttweld	ASME B16.25
Class	ASME CL800/1500

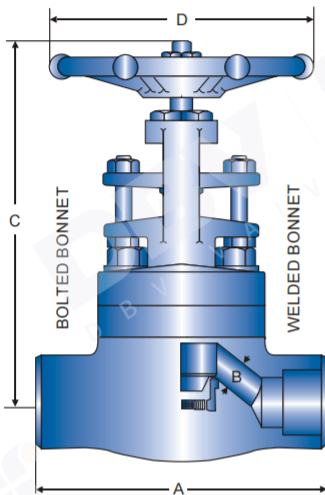

**CLASS 800 DIMENSION  
CLASS 800 WB**

SIZE (in.)	A	B	C	D	W.T (lbs)
1/2	3.2	0.35	6.3	3.2	4
3/4	3.5	0.49	6.7	3.2	4.4
1	4.3	0.68	7.9	3.9	7.3
1-1/4	5	0.88	9.3	4.7	11.9
1-1/2	6.1	1.15	9.3	5.5	17.4
2	6.7	1.37	11.4	6.7	23.8

Unit: inch

**CLASS 800 DIMENSION  
CLASS 800 BB**

SIZE (in.)	A	B	C	D	W.T (lbs)
1/2	3.2	0.35	6.3	3.2	4
3/4	3.5	0.49	6.7	3.2	4.4
1	4.3	0.68	7.9	3.9	7.3
1-1/4	5	0.88	9.3	4.7	11.9
1-1/2	6.1	1.14	9.3	5.5	17.4
2	6.7	1.37	11.4	6.7	23.8

Unit: inch

**CLASS 1500 DIMENSION  
CLASS 1500 WB**

SIZE (in.)	A	B	C	D	W.T (lbs)
1/2	3.5	0.35	6.5	3.2	4.2
3/4	4.3	0.43	7.7	4.7	7
1	4.7	0.57	9.3	5.5	12.1
1-1/4	5.1	0.75	10.4	5.5	17.6
1-1/2	6.7	1.06	11	5.5	24.2
2	8.3	1.22	13.2	6.7	29.6

Unit: inch

**CLASS 1500 DIMENSION  
CLASS 1500 BB**

SIZE (in.)	A	B	C	D	W.T (lbs)
1/2	3.5	0.35	6.5	3.2	4.4
3/4	4.3	0.43	7.7	4.7	7.3
1	4.7	0.57	9.1	5.5	12.1
1-1/4	5.1	0.75	10.2	5.5	19.8
1-1/2	6.7	1.06	11.2	6.7	26.4
2	8.3	1.22	13	6.7	39.6

Unit: inch

**FORGED STEEL GLOBE VALVE**

- Forged Steel Globe Valve, Outside Screw and York,
- Bolted, Welded & Union Bonnet, Rising Stem
- Threaded, Socketed, Buttwelded Ends
- Conventional Ports
- Designed to API 602

Face to Face	DBV Standard
Pipe Threads, G.P	ASME B1.20.1
Threaded Ends	ASME B16.11
Buttweld	ASME B16.25
Class	ASME CL2500

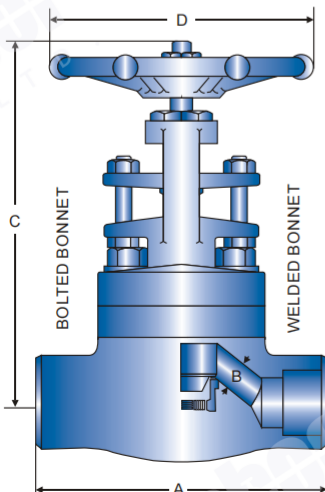

**CLASS 2500 DIMENSION  
CLASS 2500 WB**

SIZE (in.)	A	B	C	D	W.T (lbs)
1/2	4.3	0.43	7.7	4.7	8.6
3/4	4.7	0.55	8.9	5.5	14.1
1	5.1	0.75	10	5.5	19.9
1-1/4	8.3	0.94	12.8	6.7	44
1-1/2	8.3	1.1	13	6.7	48.4
2	9.5	1.42	14.6	10.2	61.6

Unit: inch

**CLASS 2500 DIMENSION  
CLASS 2500 BB**

SIZE (in.)	A	B	C	D	W.T (lbs)
1/2	4.3	0.43	10.6	4.7	11
3/4	4.7	0.55	10.8	5.5	17.6
1	5.1	0.75	11.4	5.5	23.5
1-1/4	8.3	0.94	15.4	6.7	52.8
1-1/2	8.3	1.1	16.3	10.2	70.4
2	9.5	1.42	16.7	10.2	81.4

Unit: inch

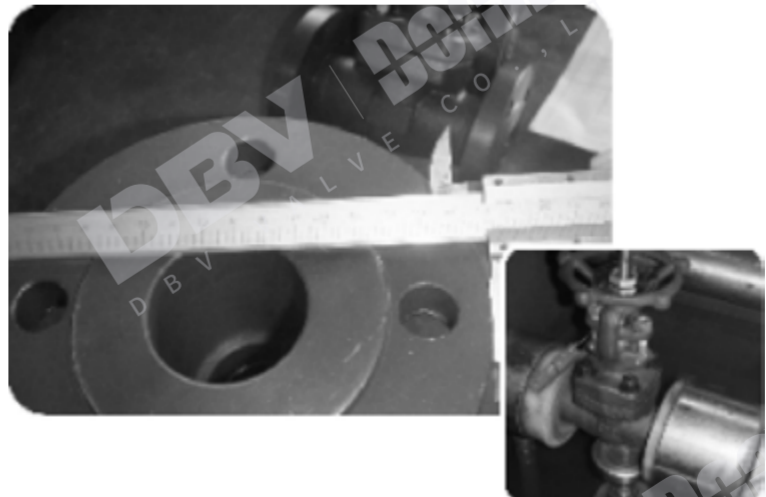



# Gate, Globe, Check Valve

## FORGED STEEL FLANGED GLOBE VALVE

- Forged Steel Globe Valve, Outside Screw and York,
- Bolted, Welded & Union Bonnet, Rising Stem
- Flanged Ends, Conventional Ports
- Designed to API 602

Face to Face	ASME/ANSI B16.10
Pipe Threads, G.P	ASME B1.20.1
Threaded Ends	ASME B16.11
Buttweld	ASME B16.25
Class	ASME CL150~CL1500

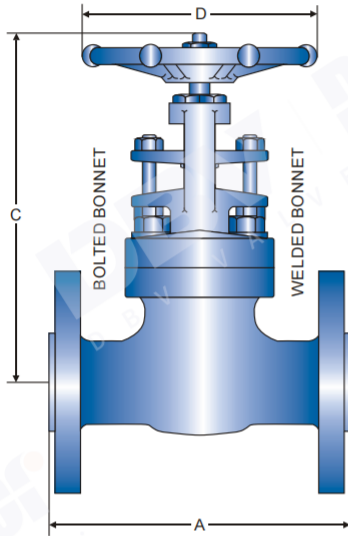

## CLASS 150 DIMENSION CLASS 150 BB&WB

SIZE (in.)	A	B	C	D	W.T (lbs)
	Unit:inch				
1/2	4.25	0.39	5.2	5.20	9.9
3/4	4.63	0.39	5.4	5.80	15.2
1	5.00	0.69	7	7.20	21.6
1-1/4	-	0.9	8.3	-	29.7
1-1/2	6.50	1.18	8.4	9.20	42.9
2	8.00	1.46	10.3	10.50	61.6

## CLASS 300 DIMENSION CLASS 300 BB&WB

SIZE (in.)	A	B	C	D	W.T (lbs)
	Unit:inch				
1/2	6.00	0.39	5.2	3.9	10.6
3/4	7.00	0.39	5.4	3.9	16.9
1	8.00	0.69	7	4.9	24.2
1-1/4	-	0.9	8.3	-	37
1-1/2	9.00	1.18	8.4	6.3	48.8
2	10.5	1.46	10.3	7.1	71.7

## CLASS 600 DIMENSION CLASS 600 BB&WB

SIZE (in.)	A	B	C	D	W.T (lbs)
	Unit:inch				
1/2	6.50	0.39	5.2	3.15	12.3
3/4	7.50	0.39	5.4	3.15	17.2
1	8.50	0.69	7	3.94	27.5
1-1/4	-	0.9	8.3	-	37.4
1-1/2	9.51	1.18	8.4	5.51	51.7
2		1.46	10.3	5.51	85.4

## CLASS 1500 DIMENSION CLASS 1500 BB&WB

SIZE (in.)	A	B	C	D	W.T (lbs)
	Unit:inch				
1/2	3.15	0.39	8.1	3.15	4.4
3/4	3.54	0.51	8.1	3.15	8.4
1	4.33	0.66	9.4	3.94	9.3
1-1/4	4.99	0.9	10.2	4.72	17.6
1-1/2	6.10	1.18	11.4	5.51	29.1
2	14.5	1.49	13.3	5.51	37

## FORGED STEEL Y PATTERN GLOBE VALVE

- Forged Steel Globe Valve, Outside Screw and York,
- Bolted, Welded & Union Bonnet, Rising Stem
- Threaded, Socketed, Buttwelded Ends
- Y Pattern, Conventional Ports
- Designed to API 602

Face to Face	DBV Standards
Pipe Threads, G.P	ASME B1.20.1
Threaded Ends	ASME B16.11
Buttweld	ASME B16.25
Class	ASME CL800~CL2500

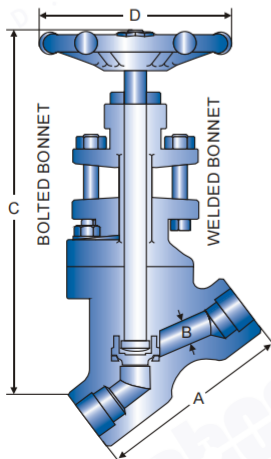

## CLASS 800 DIMENSION

SIZE (in.)	A	B	C	D	W.T (lbs)
	Unit:inch				
1/2	3.6	0.39	7.5	3.7	4.4
3/4	3.6	0.51	7.5	3.7	4.4
1	4.4	0.69	9.3	4.3	9
1-1/4	6	0.94	11.2	5.5	19.8
1-1/2	6	1.22	11.2	5.5	19.8
2	6.8	1.46	12.8	6.7	30.4

## CLASS 1500 DIMENSION

SIZE (in.)	A	B	C	D	W.T (lbs)
	Unit:inch				
1/2	3.9	0.51	7.3	3.9	6.6
3/4	4.3	0.69	9.1	5.5	8.8
1	4.9	0.89	9.4	5.5	11
1-1/4	5.9	1.1	12	6.7	20.9
1-1/2	6.3	1.38	13.4	7.9	24.2
2	7.5	1.73	15.7	10.2	37.4

## CLASS 2500 DIMENSION

SIZE (in.)	A	B	C	D	W.T (lbs)
	Unit:inch				
1/2	3.9	0.47	9.1	4.7	8.8
3/4	4.9	0.59	9.4	5.5	11
1	6.3	0.79	12	6.7	20.9
1-1/4	6.3	0.98	12	6.7	23.1
1-1/2	7.5	1.22	13.6	7.9	37.4
2	8.3	1.49	15.7	10.2	50.6

## TYPICAL DBV FORGED STEEL CHECK VALVE EXPANDED VIEW

1. Body: DBV forged steel bodies provide low resistance flow and optimum strength and performance.
2. Cover Studs: The cover studs secure the bonnet to the body.
3. Cover: The cover allows access to internal components.
4. Spring: The spring is precision made and loaded for precise pressures.
5. Piston: DBV piston is machined to the tightest tolerances to ensure trouble free shut off and cycling.
6. Cover Gasket: The cover gasket creates a leak-proof seal between the bonnet and the body.
7. Seat: The seat ensures a stable shut off. The seat is precision ground for optimal seating.

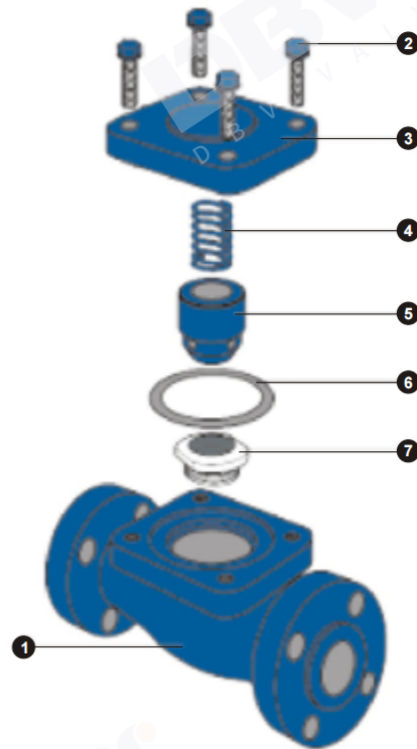

## BOLTED, WELDED & UNION CAP ● CLASS 150, 300, 600, 800, 1500 & 2500

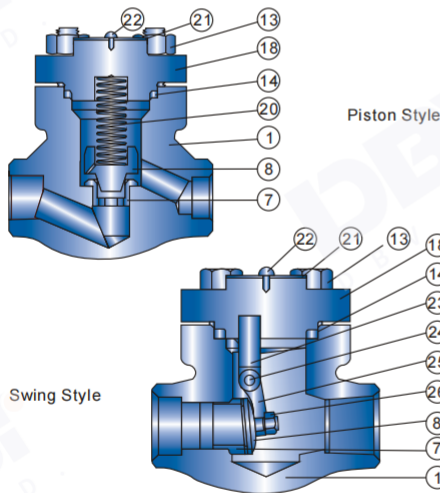

NO.	Part	Material
1	Body	A105N Carbon Steel
7	Seat	ASTMA182 F6/Stellite 6 Alloy Steel
8	Piston	ASTMA182 F6 Alloy Steel
8	Disc	ASTMA182 F6 Alloy Steel
13	Cap Screws	ASTMA193 B7M
14	Gasket	316 SS Spiral Wound Grafoil
18	Bolted Cover	A105N Carbon Steel
20	Spring	AISI 304 Stainless Steel
21	Name Plate	Aluminum
22	Rivet	Stainless Steel
23	Pin	ASTMA182 F6 Alloy Steel
24	Hinge Pin	Stainless Steel
25	Arm	ASTMA182 F6 Alloy Steel
26	Retaining Nut	ASTMA194 2HM

## DBV FORGED VALVES ARE MANUFACTURED IN STRICT ACCORDANCE WITH THE FOLLOWING STANDARDS:

API602	Compact steel gate valves
API598	Valve Inspection and Test
ANSI/ASME B16.34	Steel valve, flanged and butt-welding end
ANSI/ASME B16.5	Steel pipe flanges and flanged fittings
ANSI/ASME B16.10	Face-to-face and end-to-end dimensions of ferrous valves
ANSI/ASME B16.11	Forged steel fittings, socket welding and threaded
ANSI/ASME B1.20.1	Pipe threads, general purpose
ANSI/ASME B31.3	Chemical plant and petroleum refinery piping
MSS-SP-25	Standard marking system for valves, fittings, flanges and unions
MSS-SP-6	Standard finishes for contact faces of pipe, flanges and connecting end flanges of valves and fittings
NACE MR-01-75	Material requirements: Sulfide stress cracking resistant metallic materials for oil field equipment.

# Gate, Globe, Check Valve

## FORGED STEEL CHECK VALVE

Forged Steel Check Valve, Swing or Lift Piston  
Bolted, Welded & Union Bonnet  
Threaded, Socketed, Buttwelded Ends  
Conventional Ports  
Designed to API 602

Face to Face	DBV Standard
Pipe Threads, G.P	ASME B1.20.1
Threaded Ends	ASME B16.11
Buttweld	ASME B16.25
Class	ASME CL800

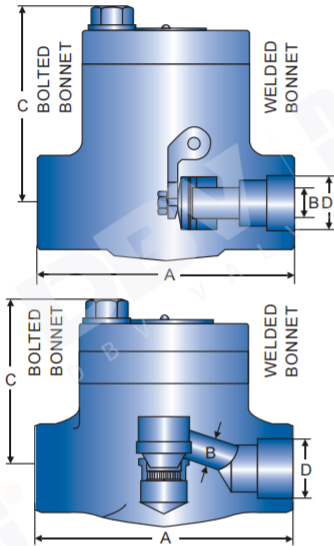

### CLASS 800 DIMENSION CLASS 800 BB LIFT

SIZE (in.)	A	B	C	D	W.T (lbs)
	Unit:inch				
1/2	3.2	0.35	1.9	0.4	2.4
3/4	3.5	0.49	2.2	0.6	4
1	4.3	0.68	2.8	0.7	5.7
1-1/4	5	0.88	3	0.9	7.9
1-1/2	6.1	1.14	4.1	1.2	12.1
2	6.7	1.38	4.7	1.4	18.5

### CLASS 800 DIMENSION CLASS 800 BB SWING

SIZE (in.)	A	B	C	D	W.T (lbs)
	Unit:inch				
1/2	3.2	0.35	1.9	0.4	2.4
3/4	3.5	0.49	2.2	0.6	4
1	4.3	0.68	2.8	0.7	5.7
1-1/4	5	0.88	3	0.9	7.9
1-1/2	6.1	1.14	4.1	1.2	12.1
2	5.1	1.44	4.7	2.4	19.6

### CLASS 800 DIMENSION CLASS 800 WB LIFT

SIZE (in.)	A	B	C	D	W.T (lbs)
	Unit:inch				
1/2	3.2	0.35	1.9	0.4	2
3/4	3.5	0.49	2.2	0.6	2.6
1	4.3	0.68	2.7	0.7	4.6
1-1/4	5	0.88	3.2	0.9	7.5
1-1/2	6.1	1.14	3.7	1.2	11.7
2	6.7	1.38	4.1	1.4	17.2

### CLASS 800 DIMENSION CLASS 800 WB SWING

SIZE (in.)	A	B	C	D	W.T (lbs)
	Unit:inch				
1/2	3.2	0.35	1.9	0.4	2
3/4	3.5	0.49	2.2	0.6	2.6
1	4.3	0.68	2.7	0.7	4.6
1-1/4	5	0.88	3.2	0.9	7.5
1-1/2	6.1	1.14	3.7	1.2	11.7
2	6.7	1.38	4.1	1.4	17.2

## FORGED STEEL CHECK VALVE

Forged Steel Check Valve, Swing or Lift Piston  
Bolted, Welded & Union Bonnet  
Threaded, Socketed, Buttwelded Ends  
Conventional Ports  
Designed to API 602

Face to Face	DBV Standard
Pipe Threads, G.P	ASME B1.20.1
Threaded Ends	ASME B16.11
Buttweld	ASME B16.25
Class	ASME CL1500

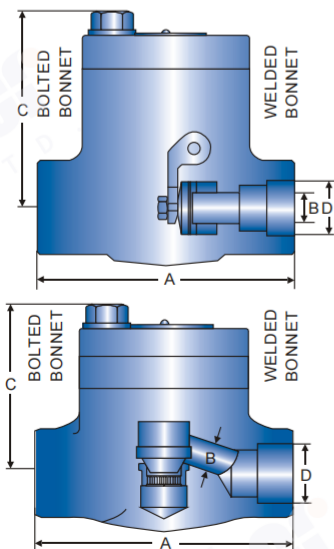

### CLASS 1500 DIMENSION CLASS 1500 BB LIFT

SIZE (in.)	A	B	C	D	W.T (lbs)
	Unit:inch				
1/2	3.5	0.35	2.2	0.4	4.8
3/4	4.3	0.43	2.8	0.6	6.8
1	4.7	0.57	3	0.7	9.2
1-1/4	5.1	0.74	4.1	0.9	12.8
1-1/2	6.7	1.06	4.5	1.2	20.7
2	8.3	1.22	5.7	1.4	26.6

### CLASS 1500 DIMENSION CLASS 1500 BB SWING

SIZE (in.)	A	B	C	D	W.T (lbs)
	Unit:inch				
1/2	3.5	0.35	2.2	0.4	4.8
3/4	4.3	0.43	2.8	0.6	6.8
1	4.7	0.57	3	0.7	9.2
1-1/4	5.1	0.74	4.1	0.9	12.8
1-1/2	6.7	1.06	4.5	1.2	20.7
2	8.3	1.22	5.7	1.4	26.6

### CLASS 1500 DIMENSION CLASS 1500 WB LIFT

SIZE (in.)	A	B	C	D	W.T (lbs)
	Unit:inch				
1/2	3.5	0.35	2.2	0.4	2.9
3/4	4.3	0.43	2.8	0.6	5.5
1	4.7	0.57	3.2	0.7	8.4
1-1/4	5.1	0.74	3.5	0.9	12.1
1-1/2	6.7	1.06	3.9	1.2	18.3
2	8.3	1.22	4.5	1.4	24.2

### CLASS 1500 DIMENSION CLASS 1500 WB SWING

SIZE (in.)	A	B	C	D	W.T (lbs)
	Unit:inch				
1/2	3.5	0.35	2.2	0.4	2.9
3/4	4.3	0.43	2.8	0.6	5.5
1	4.7	0.57	3.2	0.7	8.4
1-1/4	5.1	0.74	3.5	0.9	12.1
1-1/2	6.7	1.06	3.9	1.2	18.3
2	8.3	1.22	4.5	1.4	24.2

## FORGED STEEL FLANGED CHECK VALVE

- Forged Steel Check Valve, Swing or Lift Piston
- Bolted, Welded & Union Bonnet, Flanged Ends
- Conventional Ports
- Designed to API 602

Face to Face	DBV Standard
Pipe Threads, G.P	ASME B1.20.1
Threaded Ends	ASME B16.11
Buttweld	ASME B16.25
Class	ASME CL150~CL1500

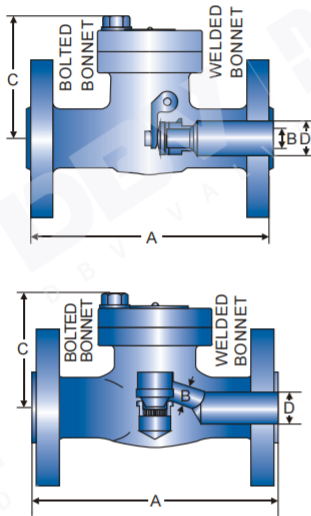

### CLASS 150 DIMENSION

SIZE (in.)	A	B (LIFT)	B (SWING)	C	D	W.T (lbs)
1/2	4.3	0.35	0.4	2.8	0.5	6.2
3/4	4.6	0.49	0.4	3.2	0.75	8.8
1	5	0.68	0.7	3.6	1	11.7
1-1/4	-	-	-	-	-	-
1-1/2	6.5	1.14	1.2	3.9	1.5	19.8
2	8	1.37	1.4	5.5	2	33

### CLASS 300 DIMENSION

SIZE (in.)	A	B (LIFT)	B (SWING)	C	D	W.T (lbs)
1/2	6	0.35	0.4	1.6	0.5	6.2
3/4	7	0.49	0.6	1.8	0.75	10.3
1	8	0.68	0.7	2.3	1	12.5
1-1/4	-	-	-	3.3	-	-
1-1/2	9	1.14	1.2	3.1	1.5	26
2	10.5	1.37	1.4	3.7	2	37.4

### CLASS 600 DIMENSION

SIZE (in.)	A	B (LIFT)	B (SWING)	C	D	W.T (lbs)
1/2	6.5	0.35	0.4	1.6	0.5	8.8
3/4	7.5	0.49	0.6	1.8	0.75	12.8
1	8.5	0.68	0.7	2.3	1	20.9
1-1/4	-	-	-	3.3	-	22.9
1-1/2	9.5	1.14	1.2	3.1	1.5	34.3
2	11.5	1.37	1.4	3.7	2	53.9

### CLASS 1500 DIMENSION

SIZE (in.)	A	B (LIFT)	B (SWING)	C	D	W.T (lbs)
1/2	8.5	0.43	0.6	3.5	0.5	16.7
3/4	9	0.57	0.7	4.1	0.69	23.8
1	10	0.74	0.9	4.7	0.87	31.9
1-1/4	-	-	-	-	-	-
1-1/2	12	1.22	1.4	6.3	1.37	68.2
2	14.5	1.48	1.6	6.7	1.87	94.6

## FORGED STEEL CV VALUES GATES, GLOBES, CHECKS

DBV Forged Gate Valves	NPS	150 - 800	150 - 800	1500	1500	2500
		Full Bore	Reduced Bore	Full Bore	Reduced Bore	Full Bore
1/2	12	6	13	6	5	
3/4	23	10	24	11	12	
1	43	26	44	27	23	
1-1/4	57	44	59	45	43	
1-1/2	98	65	100	66	56	
2	200	103	*	99	97	

DBV Forged Y-Pattern Globe Valves	NPS	800	1500	2500
1/2	5	5	3	
3/4	11	11	6	
1	14	15	12	
1-1/4	-	-	-	
1-1/2	37	35	27	
2	68	68	36	

DBV Forged Lift Check Valves	NPS	150 - 800	150 - 800	1500	1500
		Full Bore	Reduced Bore	Full Bore	Reduced Bore
1/2	3	1	3	2	
3/4	5	3	6	3	
1	11	6	11	5	
1-1/4	-	-	-	-	
1-1/2	18	15	19	11	
2	32	18	22	19	

DBV Forged Globe Valves	NPS	150 - 800	150 - 800	1500	1500
		Full Bore	Reduced Bore	Full Bore	Reduced Bore
1/2	3	2	3	2	
3/4	6	4	6	3	
1	12	6	12	6	
1-1/4	15	10	-	-	
1-1/2	21	18	20	16	
2	38	22	24	20	

DBV Forged Swing Check Valves	NPS	150 - 800	150 - 800	1500	1500
		Full Bore	Reduced Bore	Full Bore	Reduced Bore
1/2	5	4	-	-	
3/4	12	6	-	-	
1	17	13	-	-	
1-1/4	26	18	-	-	
1-1/2	54	28	-	-	
2	101	55	-	-	

DBV Forged Y-Pattern Lift Check Valves	NPS	800	1500	2500
1/2	4	4	3	
3/4	11	11	6	
1	13	14	12	
1-1/4	-	-	-	
1-1/2	36	34	27	
2	67	67	36	

Table Applies to Both Piston and Ball Check Valves

# Gate, Globe, Check Valve

## FEATURES

### DOUBLE D PLUG STEM

Accepts most standard actuation equipment.

### LOCKOUT

Meets OSHA and plant safety requirements.

### IN-LINE ADJUSTMENT

Prevents thru-line leakage.

### PTFE SLEEVE

Large seal area offers positive shutoff and extended service life.

### ACTUATOR MOUNTING PADS

Mounts directly on flanges for solid support.

### TAPERED PLUG

Assures reduced turning torque and in-line seal adjustment and wear. Adjustment is independent of stem seals. With  $\pm 3/16$  in ( $\pm 5$  mm) adjustment, plug cannot bottom out.

### PFA REVERSE LIP DIAPHRAGM

Provides static and dynamic, self-adjusting stem seal.

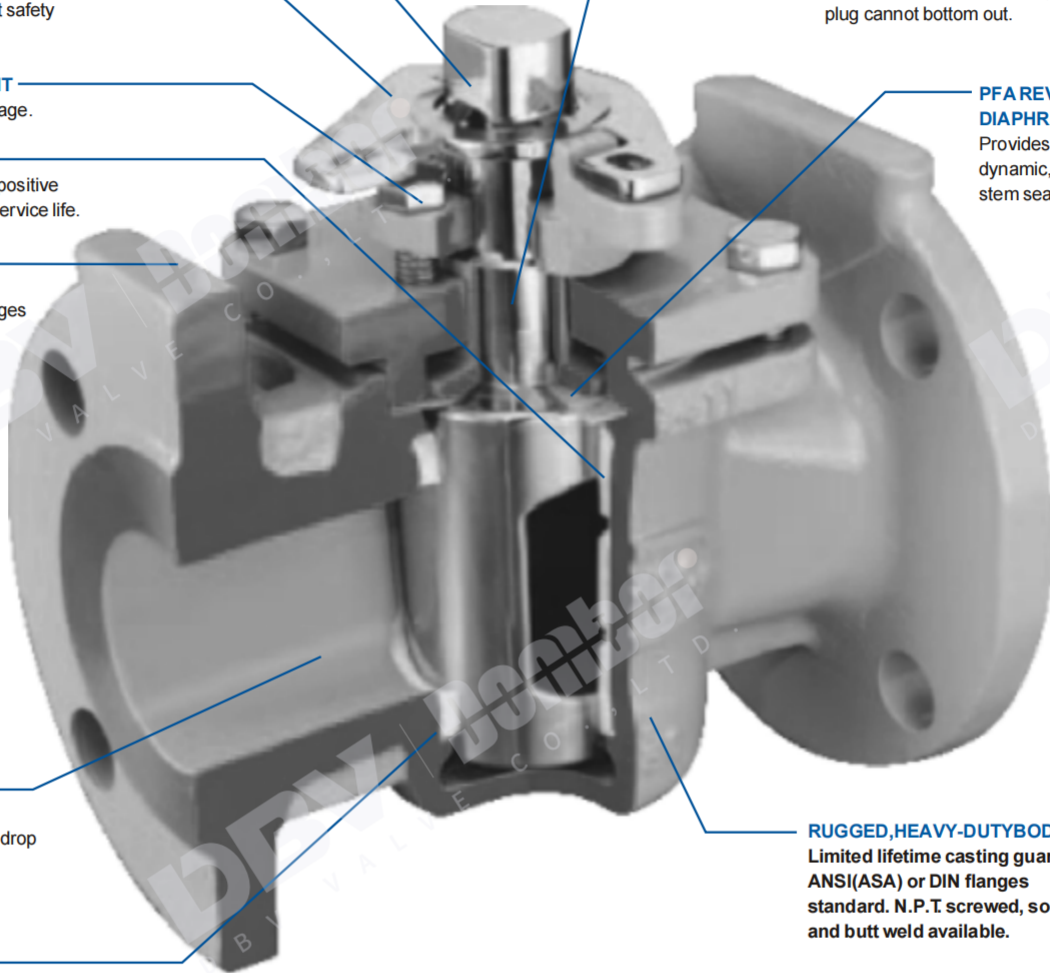

### LARGE PORT OPENINGS

Assure less pressure drop and higher Cv.

### RAISED LOCKING RIBS

Along with grooves and recesses positively lock sleeve in body.

### WIDE MATERIALS SELECTION

Corrosion resistant stainless steels, nickel base and reactive alloys.

### RUGGED, HEAVY-DUTY BODY

Limited lifetime casting guarantee. ANSI(ASA) or DIN flanges standard. N.P.T screwed, socket and butt weld available.

## MAIN PARTS MATERIALS

NO.	PART NAME	MATERIAL
1	Body	ASTM A216-WCB   ASTM A217-WC1, WC6, WC9, C5   ASTM A351-CF8, CF8M, CF3, CF3M
2	Plug	ASTM A182-Gr.F6a   ASTM A182-F22   ASTM A182-F304, F316, F321, F304L, F316L
3	Gasket	Flexible graphite+stainless steel, PTFE
4	Cover	ASTM A216-WCB   ASTM A217-WC1, WC6, WC9, C5   ASTM A351-CF8, CF8M, CF3, CF3M
5	Bolt	ASTM A193-B7, A320-B8, A193-B8M
6	Nut	ASTM A194-2H, A194-8, A194-8M
7	Packing	Flexible graphite+stainless steel, PTFE
8	Gland	ASTM A216-WCB   ASTM A217-WC1, WC6, WC9, C5   ASTM A351-CF8, CF8M, CF3, CF3M
9	Wrench	ASTM A216-WCB   ASTM A351-CF8, CF8M, CF3, CF3M
10	Yoke nut	ZQA19-4
11	Handwheel	ASTM A536 Gr.60-40-18, ASTM A216-WCB

OTHER MATERIALS AVAILABLE UPON REQUEST

**INVERTED PRESSURE BALANCE LUBRICATED PLUG VALVE**

Cast Steel Plug Valve  
Outside Screw and York, Bolted Cover  
Oil-Lubricated, Pressure Balance  
Designed to API 599, API 6D

Face to Face	ASME/ANSI B16.10
End Flange	ASME/ANSI B16.5
Butt Weld	ASME/ANSI B16.25
Class	ASME/ANSI CL150~CL900

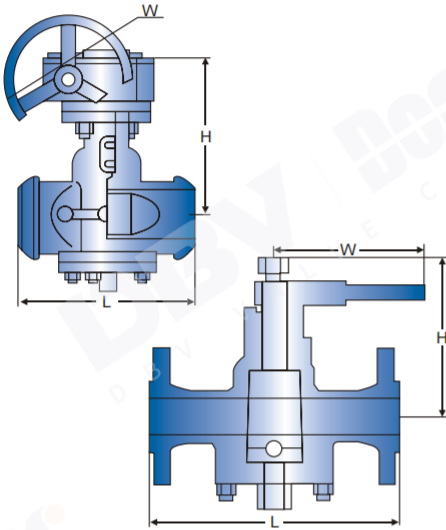

**CLASS 150 DIMENSIONS**

SIZE (in.)	1/2"	3/4"	1"	1-1/4"	1-1/2"	2"	2-1/2"	3"	4"	5"	6"	8"	10"	12"	14"
L	108	117	127	140	165	178	190	203	229	254	267	292	330	356	381
H	180	180	185	200	210	215	250	270	300	340	365	400	450	510	590
W	400	400	500	500	600	600	820	820	300	300	320	320	350	380	380
W.T(kg)	10	12	14	17	19	21	29	33	48	75	98	125	171	230	370

**CLASS 300 DIMENSIONS**

SIZE (in.)	1/2"	3/4"	1"	1-1/4"	1-1/2"	2"	2-1/2"	3"	4"	5"	6"	8"	10"	12"	14"
L	140	152	165	178	190	216	241	283	305	381	403	419	457	502	762
H	180	180	185	200	210	215	250	270	300	340	365	400	450	510	590
W	400	400	500	600	600	820	1000	1000	300	300	320	320	350	380	380
W.T(kg)	12	14	14	19	21	24	31	36	61	86	130	190	255	380	560

**CLASS 600 DIMENSIONS**

SIZE (in.)	1/2"	3/4"	1"	1-1/4"	1-1/2"	2"	2-1/2"	3"	4"	5"	6"	8"	10"	12"	14"
L	165	190	216	229	241	292	330	356	432	508	559	660	787	838	889
H	180	180	185	200	210	215	250	270	300	340	365	400	450	510	590
W	400	400	500	500	600	600	820	820	300	300	320	320	350	380	380
W.T(kg)	14	16	18	20	24	29	35	47	91	129	210	320	660	920	1250

**CLASS 900 DIMENSIONS**

SIZE (in.)	1/2"	3/4"	1"	1-1/4"	1-1/2"	2"	2-1/2"	3"	4"	5"	6"	8"	10"	12"	14"
L	229	229	254	279	305	368	419	381	457	559	610	737	838	965	1029
H	180	180	185	200	210	215	250	270	300	340	365	400	450	510	590
W	400	400	500	60	600	820	1000	1000	300	300	320	320	350	380	380
W.T(kg)	17	19	21	24	30	37	44	65	110	160	255	380	810	1050	1460

**ANSI STANDARD SLEEVE TYPE PLUG VALVE**

Cast Steel Plug Valve  
Outside Screw and York, Bolted Cover  
Resilient Seat Sleeved  
Designed to API 599, API 6D

Face to Face	ASME/ANSI B16.10
End Flange	ASME/ANSI B16.5
Butt Weld	ASME/ANSI B16.25
Class	ASME/ANSI CL150~CL900

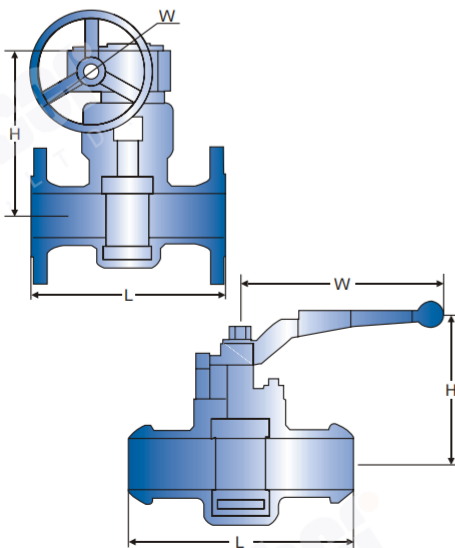

**CLASS 150 DIMENSIONS**

SIZE (in.)	1/2"	3/4"	1"	1-1/4"	1-1/2"	2"	2-1/2"	3"	4"	5"	6"	8"	10"	12"	14"
L	108	117	127	140	165	178	190	203	229	254	267	292	330	356	381
H	110	115	115	135	140	150	165	180	380	460	520	580	620	680	760
W	175	175	175	220	280	305	350	405	300	300	320	320	350	380	450
W.T(kg)	8.5	9.5	10.5	12	14	18	22	26	40	60	70	130	219	381	570

**CLASS 300 DIMENSIONS**

SIZE (in.)	1/2"	3/4"	1"	1-1/4"	1-1/2"	2"	2-1/2"	3"	4"	5"	6"	8"	10"	12"	14"
L	140	152	165	178	190	216	241	283	305	381	403	419	457	502	762
H	110	115	115	135	140	150	165	180	380	460	520	580	620	680	760
W	175	175	175	220	280	305	350	405	300	300	320	320	350	380	450
W.T(kg)	9.5	10.5	12	14	16	20	24	29	53	75	85	185	230	390	550

**CLASS 600 DIMENSIONS**

SIZE (in.)	1/2"	3/4"	1"	1-1/4"	1-1/2"	2"	2-1/2"	3"	4"	5"	6"	8"	10"	12"	14"
L	165	190	216	229	241	292	330	356	432	508	559	660	787	838	889
H	110	115	115	135	140	150	165	180	380	460	520	580	620	680	760
W	175	175	175	220	280	305	350	405	300	300	320	320	350	380	450
W.T(kg)	11	13	17	20	23	27	31	36	72	98	141	245	330	515	710

**CLASS 900 DIMENSIONS**

SIZE (in.)	1/2"	3/4"	1"	1-1/4"	1-1/2"	2"	2-1/2"	3"	4"	5"	6"	8"	10"	12"	14"
L	229	229	254	279	305	368	419	381	457	559	610	737	838	965	1029
H	110	115	115	135	140	150	165	180	380	460	520	580	620	680	760
W	175	175	175	220	280	305	350	405	300	300	320	320	350	380	450
W.T(kg)	13	16	21	24	28	32	40	47	91	117	165	285	420	610	860

# Plug Valve

## DIN STANDARD SLEEVE TYPE PLUG VALVE

Cast Steel Plug Valve  
Outside Screw and York, Bolted Cover  
Resilient Seat Sleeved  
Designed to DIN Standard

Face to Face	DIN3202 F1
End Flange	DIN 2543~2549
Butt Weld	EN12627
Class	PN16~PN64

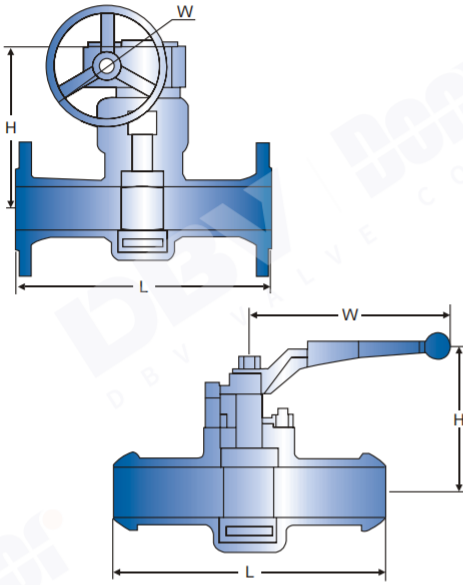

### PN16 DIMENSIONS

SIZE (DN)	15	20	25	32	40	50	65	80	100	125	150	200	250	300	350
L	130	150	160	180	200	230	290	310	350	400	480	600	730	850	980
H	150	155	160	180	190	200	220	230	380	460	520	580	620	680	740
W	300	300	300	350	400	500	500	550	300	300	320	320	350	380	380
W.T(kg)	9	10	11	13	14	19	23	27	43	62	75	155	222	390	580

### PN25 DIMENSIONS

SIZE (DN)	15	20	25	32	40	50	65	80	100	125	150	200	250	300	350
L	130	150	160	180	200	230	290	310	350	400	480	600	730	850	980
H	150	155	160	180	190	200	220	230	380	460	520	580	620	680	740
W	300	300	300	350	400	500	500	550	300	300	320	320	350	380	380
W.T(kg)	10	11	13	15	17	22	31	55	77	88	190	190	235	399	580

### PN40 DIMENSIONS

SIZE (DN)	15	20	25	32	40	50	65	80	100	125	150	200	250	300	350
L	130	150	160	180	200	230	290	310	350	400	480	600	730	850	980
H	190	195	225	260	280	310	340	395	435	470	535	590	630	680	720
W	120	140	140	180	200	220	260	280	300	340	400	450	450	500	500
W.T(kg)	12	14	18	21	24	29	33	39	75	103	146	251	337	521	720

### PN64 DIMENSIONS

SIZE (DN)	15	20	25	32	40	50	65	80	100	125	150	200	250	300	350
L	130	150	160	180	200	230	290	310	350	400	480	600	730	850	980
H	190	195	225	260	280	310	340	395	435	470	535	590	630	680	720
W	120	140	140	180	200	220	260	280	300	340	400	450	450	500	500
W.T(kg)	14	17	22	25	29	34	43	50	94	123	170	291	430	625	875

## LIFTING PLUG VALVE

Cast Steel Plug Valve, Lift Pattern  
Outside Screw and York, Bolted Cover  
Designed to API 599, API 6D

Face to Face	ASME/ANSI B16.10
End Flange	ASME/ANSI B16.5
Butt Weld	ASME/ANSI B16.25
Class	ASME/ANSI CL150~CL300

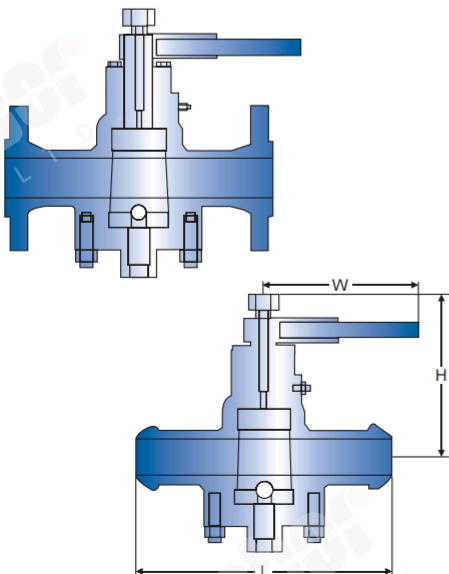

### CLASS 150 DIMENSIONS

SIZE (in.)	1/2"	3/4"	1"	1-1/4"	1-1/2"	2"	2-1/2"	3"	4"	5"	6"	8"	10"	12"	14"
L	108	117	127	140	165	178	190	203	229	254	267	292	330	356	381
H	190	195	225	260	280	310	340	395	435	470	535	590	630	680	720
W	120	140	140	180	200	220	260	280	300	340	400	450	450	500	500
W.T(kg)	9	10	11	17	19	23	25	32	55	82	98	130	178	250	380

### CLASS 300 DIMENSIONS

SIZE (in.)	1/2"	3/4"	1"	1-1/4"	1-1/2"	2"	2-1/2"	3"	4"	5"	6"	8"	10"	12"	14"
L	140	152	165	178	190	216	241	283	305	381	403	419	457	502	762
H	190	195	225	260	280	310	340	395	435	470	535	590	630	680	720
W	120	140	140	180	200	220	260	280	300	340	400	450	450	500	500
W.T(kg)	10	12	14	19	21	28	34	39	75	95	135	200	255	415	650

**LIFTING PLUG VALVE**

Cast Steel Plug Valve, Lift Pattern  
Outside Screw and York, Bolted Cover  
Designed to API 599, API 6D

Face to Face	ASME/ANSI B16.10
End Flange	ASME/ANSI B16.5
Butt Weld	ASME/ANSI B16.25
Class	ASME/ANSI CL600~CL900

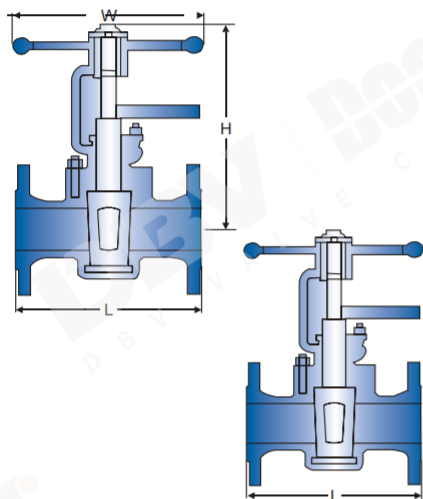

**CLASS 600 DIMENSIONS**

SIZE (in.)	1/2"	3/4"	1"	1-1/4"	1-1/2"	2"	2-1/2"	3"	4"	5"	6"	8"	10"	12"	14"
L	165	190	216	229	241	292	330	356	432	508	559	660	787	838	889
H	190	195	225	260	280	310	340	395	435	470	535	590	630	680	720
W	120	140	140	180	200	220	260	280	300	340	400	450	450	500	500
W.T(kg)	13	14	19	23	25	32	40	55	105	139	300	440	730	1150	1570

Unit: mm

**CLASS 900 DIMENSIONS**

SIZE (in.)	1/2"	3/4"	1"	1-1/4"	1-1/2"	2"	2-1/2"	3"	4"	5"	6"	8"	10"	12"	14"
L	229	229	254	279	305	368	419	381	457	559	610	737	838	965	1029
H	190	195	225	260	280	310	340	395	435	470	535	590	630	680	720
W	120	140	140	180	200	220	260	280	300	340	400	450	450	500	500
W.T(kg)	16	17	26	30	33	39	50	70	137	181	397	590	860	1470	1880

Unit: mm

**ORBIT PLUG VALVE**

Cast Steel Plug Valve, Orbited  
Double Block and Bleed  
Outside Screw and York, Bolted Cover  
Designed to API 599, API 6D

Face to Face	ASME/ANSI B16.10
End Flange	ASME/ANSI B16.5
Butt Weld	ASME/ANSI B16.25
Class	ASME/ANSI CL150~CL900

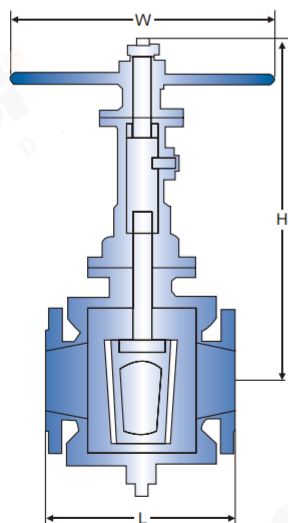

**CLASS 150 DIMENSIONS**

SIZE (in.)	1/2"	3/4"	1"	1-1/4"	1-1/2"	2"	2-1/2"	3"	4"	5"	6"	8"	10"	12"	14"
L	108	117	127	140	165	178	190	203	229	254	267	292	330	356	381
H	230	260	300	340	380	435	460	490	525	570	625	700	780	870	980
W	120	140	140	180	200	220	260	280	300	340	40	450	450	500	500
W.T(kg)	10	12	14	19	21	28	34	39	75	95	135	200	255	415	650

Unit: mm

**CLASS 300 DIMENSIONS**

SIZE (in.)	1/2"	3/4"	1"	1-1/4"	1-1/2"	2"	2-1/2"	3"	4"	5"	6"	8"	10"	12"	14"
L	140	152	165	178	190	216	241	283	305	381	403	419	457	502	762
H	230	260	300	340	380	435	460	490	525	570	625	700	780	870	980
W	120	140	140	180	200	220	260	280	300	340	400	450	450	500	500
W.T(kg)	11	13	20	27	31	37	44	60	82	115	165	225	305	405	650

Unit: mm

**CLASS 600 DIMENSIONS**

SIZE (in.)	1/2"	3/4"	1"	1-1/4"	1-1/2"	2"	2-1/2"	3"	4"	5"	6"	8"	10"	12"	14"
L	165	190	216	229	241	292	330	356	432	508	559	660	787	838	889
H	230	260	300	340	380	435	460	490	525	570	625	700	780	870	980
W	120	140	140	180	200	220	260	280	300	340	400	450	450	500	500
W.T(kg)	8.5	15	22	29	34	41	54	68	99	128	191	258	430	650	870

Unit: mm

**CLASS 900 DIMENSIONS**

SIZE (in.)	1/2"	3/4"	1"	1-1/4"	1-1/2"	2"	2-1/2"	3"	4"	5"	6"	8"	10"	12"	14"
L	229	229	254	279	305	368	419	381	457	559	610	737	838	965	1029
H	230	260	300	340	380	435	460	490	525	570	625	700	780	870	980
W	120	140	140	180	200	220	260	280	300	340	400	450	450	500	500
W.T(kg)	15	19	24	32	38	47	62	75	115	147	220	379	490	720	1020

Unit: mm



# Slab Gate Valve

## DBV THROUGH CONDUIT VALVE DESIGN FEATURES

The DBV valve's through conduit expanding gate design provides specific advantages resulting in reliable performance and long life. The Expanding Gate valves perform in critical applications as block valves in process system refineries, pipelines and isolation valves in power plant.

### FULL BORE

Permits the passage of cleaning and scraping tools. Turbulence and pressure drops are minimized. Through conduit Valve body cavity is isolated from flow.

### EXPANDING GATE

The valve's parallel expanding gate provides a simultaneous tight mechanical seat seal upstream and downstream against the seats in both open or closed position. Seal is not affected by pressure changes, heat or vibration

### SEATS

Seat faces are in full contact with the gate whether the valve is closed or open, hence outside the flow stream for a long life operation. The seats are energized by line pressure and spring loaded and mechanical action of the double disc. Primary seat seal elastomer inserts are placed into a groove, supported by a secondary metal-to-metal seating. Seats can be removed and replaced while the valve is in line. Parallel expanding gate allows a tight mechanical seal both upstream and downstream.

A. During travel, the gate and segment assembly is collapsed and matches at all four surfaces. The face-to-face width of gate is less than distance between seats so that gate & segment travel freely without sticking or wedging.

B. In closed position, the two top angles are in contact. With further downward movement the segment halted against the stop, so that the continued descent of the gate allow the solid gate segment -surface to expand, against the seats.

C. In open position the two bottom angles are in contact. With further upward movement of the segment the gate/segment assembly expand, sealing against the seats and isolating the body cavity from the flow.

### BLOCK & BLEED CAPABILITY

Tight closure at both seats allows body cavity to be drained with pressure both up and down stream.

### STEM & STEM PACKING

Improved Chevron type "v" style interlocking stem packing rings with provision made for sealant/lubricant injection into packing chamber.

### SEALANT INJECTION

Emergency sealing injection facility can be provided on valves 6" and larger size.

### PERMANENT LUBRICATION

DBV Valve's gate and stem can be coated with solid film lubricant, corrosion resistant, low friction material which lubricates wearing surface.

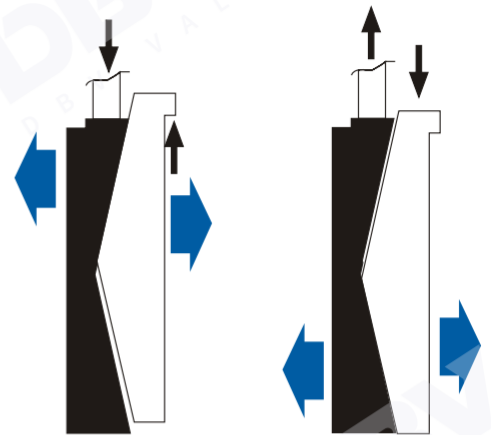

CLOSED POSITION

OPEN POSITION

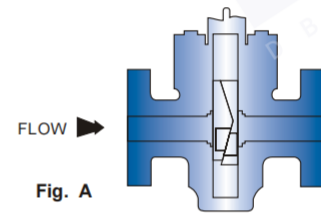

Fig. A

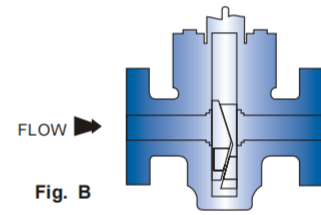

Fig. B

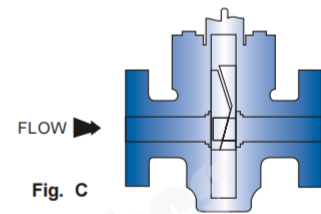
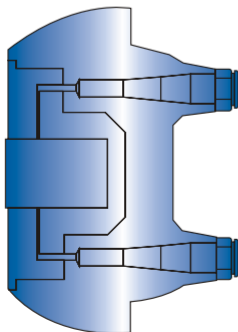
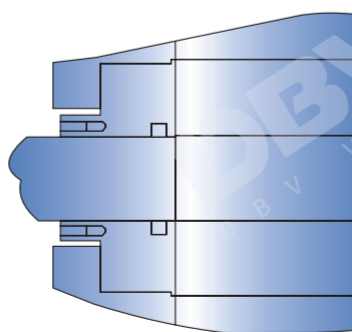

Fig. C



SEALANT INJECTION SYSTEM



SPRING ENERGIZED FLOATING SEATS

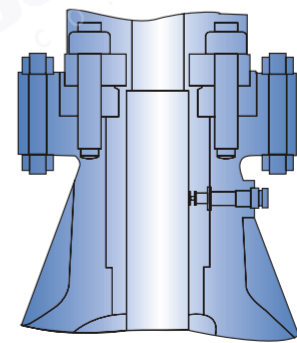

TYPICAL STEM PACKING CONSTRUCTION

**FLOW CHARACTERISTIC**

**DIFFERENT TYPES OF SHUTTER**

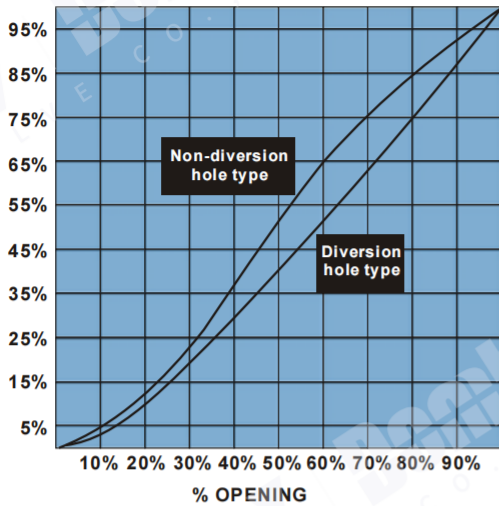

**ORDINARY TYPE**



**ADJUSTMENT TYPE**

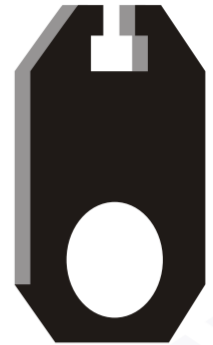

**TYPE ADIVERSION HOLE**

**DN-CV GRAPH OF SLAB GATE VALVE WITH A DIVERSION HOLE**

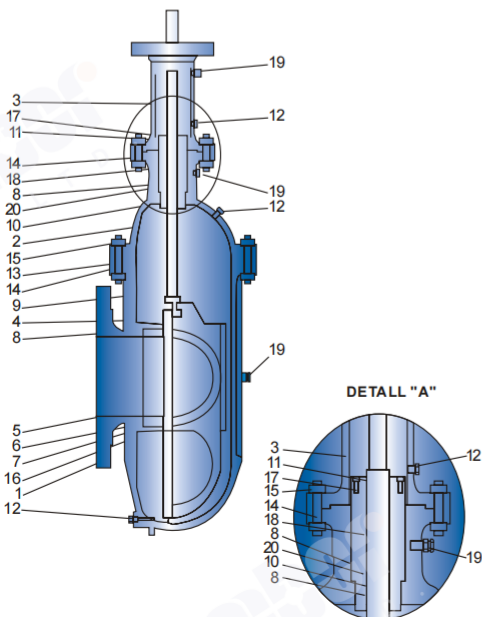
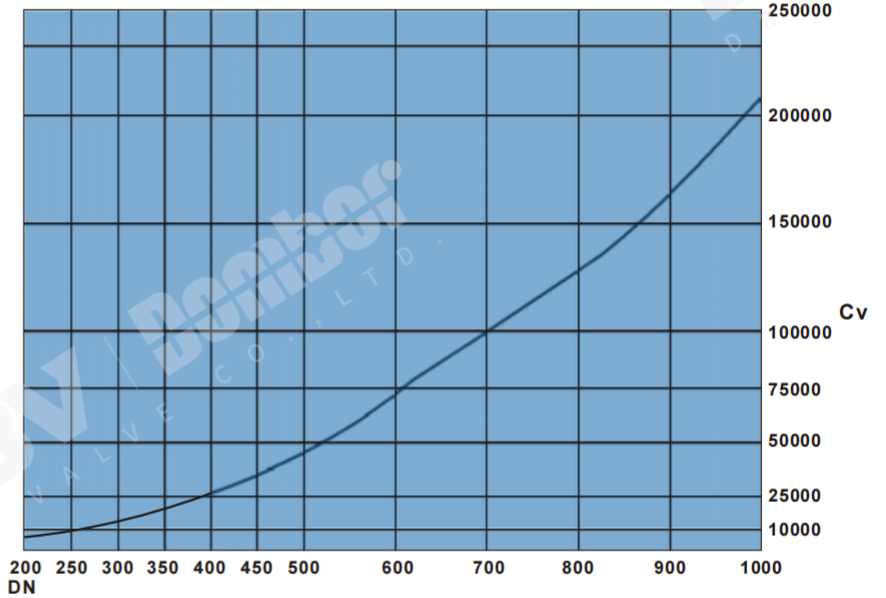
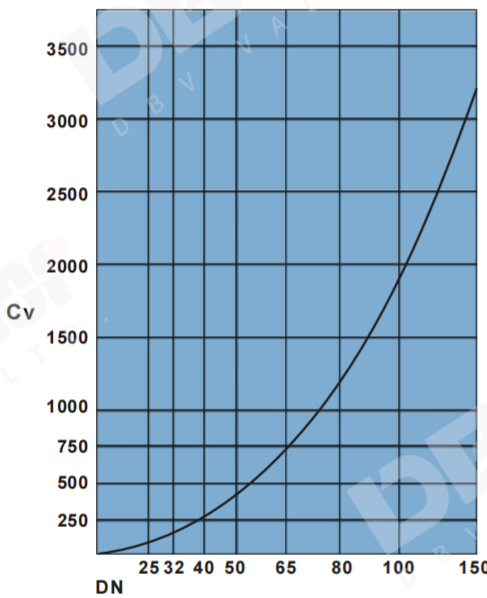

**MAIN PARTS MATERIALLIST**

NO	PART NAME	MATERIAL	NO	PART NAME	MATERIAL
1	Body	A216 WCB	11	Gland flange	A180 F304 + O-ring
2	Bonnet	A216 WCB	12	Plug	A105
3	Yoke	A216 WCB	13	Body/Bonnet S.W. Gasket	AISI 316 + GRAPHITE
4	Gate	A182 F6A + ENP	14	Bolt	A193 B7
5	Seat ring	A182 F6A	15	Nut	A194 Gr.2H
6	Spring	INCONEL X750	16	Gate Plate Guide	CARBON STEEL
7	Insert	PTFE	17	Screw	Steel 12.9
8	O-ring	VITON	18	Lantern Ring	AISI 304
9	Stem	A182 F6A	19	Seal Injection Fittings	INOX STAINLESS STEEL
10	Stem Bushong	A182 F304	20	Stem Packing	PTFE

# Slab Gate Valve

## THROUGH CONDUIT GATE VALVE

Cast Steel Slab Gate Valve  
 Outside Screw and York, Rising Stem,  
 Double Block and Bleed, Self-relieving  
 Emergency Sealing Injection System  
 Designed to API 6D

Face to Face	ASME/ANSI B16.10
End Flange	ASME/ANSI B16.5
Butt Weld	ASME/ANSI B16.25
Class	ASME/ANSI CL150

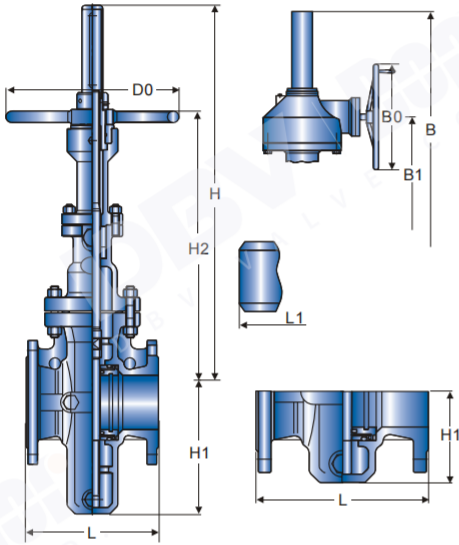

## CLASS 150 DIMENSIONS

SIZE	FLG L	B.W L1	H	H2	D0	B	B1	B0	G.O SIZE	H1
(in.)										Unit:mm
1	127	127	360	250	180	-	-	-	-	85
1-1/4	140	140	375	260	180	-	-	-	-	103
1-1/2	165	165	410	290	250	-	-	-	-	115
2	178	216	450	315	250	-	-	-	-	122
2-1/2	190	241	550	420	300	-	-	-	-	154
3	203	283	610	428	300	-	-	-	-	169
4	229	305	700	494	300	770	650	310	BA-0	193
6	267	403	895	625	350	965	800	310	BA-0	283
8	292	419	1130	784	350	1200	960	310	BA-0	352
10	330	457	1290	937	400	1360	1080	310	BA-0	440
12	356	502	1480	1080	450	1560	1200	310	BA-0	514
14	381	572	1660	1283	500	1740	1350	460	BA-1	602
16	406	610	1850	1417	500	1930	1500	460	BA-1	678
18	432	660	2080	1489	600	2160	1680	460	BA-1	785
20	457	711	2300	1672	700	2420	1850	460	BA-1	855
24	508	813	2680	2012	800	2800	2120	460	BA-2	1045
28	610	914	3080	2250	800	3200	2450	460	BA-2	1190
32	660	965	3491	2550	1000	3640	2800	460	BA-2	1350
36	711	1016	3897	2850	1000	4050	3080	600	BA-3	1510
40	811	-	4317	3250	1200	4467	3400	600	BA-3	1715

## THROUGH CONDUIT GATE VALVE

Cast Steel Slab Gate Valve  
 Outside Screw and York, Rising Stem,  
 Double Block and Bleed, Self-relieving  
 Emergency Sealing Injection System  
 Designed to API 6D

Face to Face	ASME/ANSI B16.10
End Flange	ASME/ANSI B16.5
Butt Weld	ASME/ANSI B16.25
Class	ASME/ANSI CL300

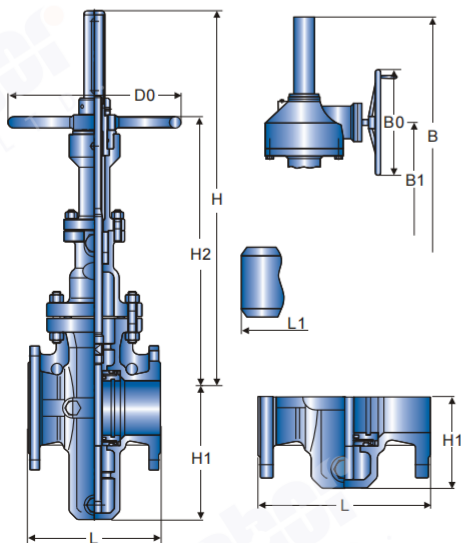

## CLASS 300 DIMENSIONS

SIZE	FLG L	B.W L1	H	H2	D0	B	B1	B0	G.O SIZE	H1
(in.)										Unit:mm
1	165	165	370	260	180	-	-	-	-	90
1-1/4	178	178	385	270	180	-	-	-	-	115
1-1/2	190	190	420	300	250	-	-	-	-	130
2	216	216	458	325	250	-	-	-	-	137
2-1/2	241	241	555	420	300	-	-	-	-	169
3	283	283	615	430	300	-	-	-	-	184
4	305	305	710	500	300	770	650	310	BA-0	218
6	403	403	900	625	350	965	800	310	BA-0	311
8	419	419	1135	790	350	1200	960	310	BA-0	382
10	457	457	1401	1040	400	1360	1090	310	BA-0	476
12	502	502	1580	1150	450	1560	1200	310	BA-1	545
14	572	762	-	-	-	1740	1350	460	BA-1	645
16	610	838	-	-	-	1930	1540	460	BA-1	728
18	660	914	-	-	-	2160	1700	460	BA-1	800
20	711	991	-	-	-	2420	1850	460	BA-2	930
24	787	1143	-	-	-	2800	2120	460	BA-2	1100
28	914	1346	-	-	-	3200	2460	460	BA-2	1260
32	965	1524	-	-	-	3640	2800	460	BA-2	1420
36	1016	1727	-	-	-	4050	3080	600	BA-3	1510

**THROUGH CONDUIT GATE VALVE**

Cast Steel Slab Gate Valve  
 Outside Screw and York, Rising Stem,  
 Double Block and Bleed, Self-relieving  
 Emergency Sealing Injection System  
 Designed to API 6D

Face to Face	ASME/ANSI B16.10
End Flange	ASME/ANSI B16.5
Butt Weld	ASME/ANSI B16.25
Class	ASME/ANSI CL400

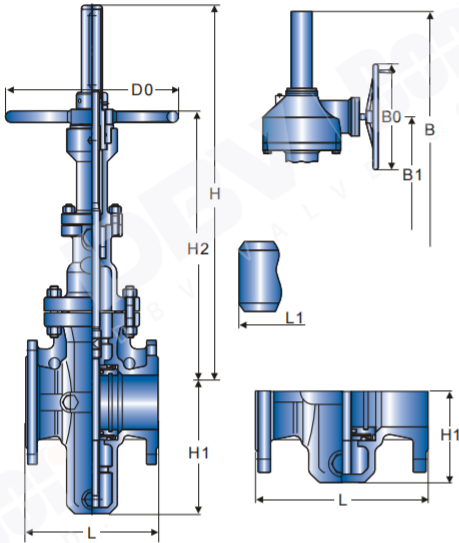

**CLASS 400 DIMENSIONS**

SIZE (in.)	FLG L	B.W L1	H	H2	D0	B	B1	B0	G.O SIZE	H1
2	216	292	458	325	300	505	430	310	BA-0	158
2-1/2	241	330	555	420	300	560	470	310	BA-0	190
3	283	356	615	430	350	610	510	310	BA-0	225
4	305	406	710	500	350	770	650	310	BA-0	255
6	403	495	900	625	400	965	800	310	BA-0	330
8	419	597	1135	790	500	1200	960	310	BA-0	410
10	457	673	1401	1040	500	1370	1090	460	BA-1	490
12	502	762	1580	1150	600	1560	1200	460	BA-1	570
14	762	826	-	-	-	1740	1350	460	BA-1	650
16	838	902	-	-	-	1970	1540	460	BA-2	735
18	914	978	-	-	-	2260	1700	460	BA-2	810
20	991	1054	-	-	-	2420	1850	460	BA-2	905
24	1143	1232	-	-	-	2800	2120	600	BA-3	1070
28	1346	1397	-	-	-	3230	2460	600	BA-3	1230

**THROUGH CONDUIT GATE VALVE**

Cast Steel Slab Gate Valve  
 Outside Screw and York, Rising Stem,  
 Double Block and Bleed, Self-relieving  
 Emergency Sealing Injection System  
 Designed to API 6D

Face to Face	ASME/ANSI B16.10
End Flange	ASME/ANSI B16.5
Butt Weld	ASME/ANSI B16.25
Class	ASME/ANSI CL600/900

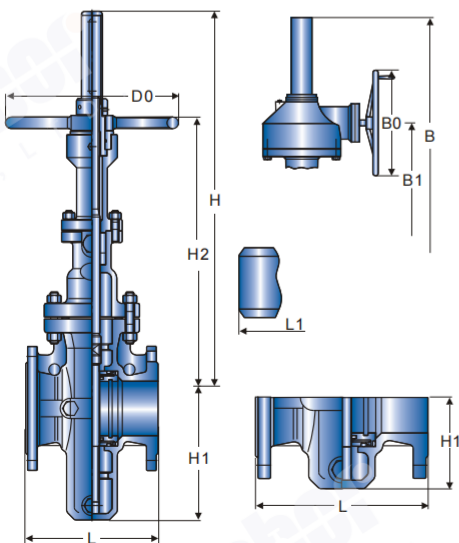

**CLASS 600 DIMENSIONS**

SIZE (in.)	FLG L	B.W L1	H	H2	D0	B	B1	B0	G.O SIZE	H1
2	250	292	468	335	300	505	430	310	BA-0	158
2 1/2	280	330	565	430	300	560	470	310	BA-0	190
3	310	356	625	440	350	610	510	310	BA-0	225
4	350	432	720	510	350	770	650	310	BA-0	255
6	450	559	910	630	400	965	800	310	BA-0	330
8	550	660	1145	800	500	1200	960	310	BA-1	410
10	650	787	1411	1050	500	1370	1090	460	BA-1	490
12	750	838	1590	1160	600	1560	1200	460	BA-1	570
14	850	889	-	-	-	1740	1350	460	BA-2	650
16	950	991	-	-	-	1970	1540	460	BA-2	735
18	1050	1092	-	-	-	2260	1700	460	BA-2	810
20	1150	1194	-	-	-	2420	1850	460	BA-2	905

**CLASS 900 DIMENSIONS**

SIZE (in.)	FLG L	B.W L1	H	H2	D0	B	B1	B0	G.O SIZE	H1
2	300	368	473	335	300	525	450	310	BA-0	158
2-1/2	340	419	570	435	300	585	490	310	BA-0	190
3	380	381	630	445	350	635	530	310	BA-0	225
4	430	457	725	515	350	800	680	310	BA-0	255
6	500	610	915	640	400	995	830	310	BA-1	330
8	580	737	1150	800	500	1250	1000	460	BA-1	410
10	680	838	1416	1055	500	1420	1140	460	BA-1	490
12	775	965	1595	1165	600	1600	1230	460	BA-2	570

# Slab Gate Valve

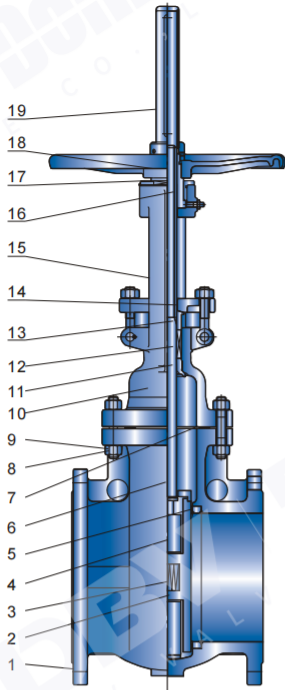

## MAIN PARTS MATERIAL LIST

NO.	PART NAME	MATERIAL TO ASTM	
		STANDARD	ANTI-SULPHUR
1	Body	A216-WCB	A216-WCB
2	Disc	A105+STL	A276-304+STL
3	Spring	Inconel X-750	Inconel X-750
4	Disc frame	A216-WCB	A216-WCB
5	Seat	A105+STL	A276-304+STL
6	Stem	A276-410	A276-304
7	Gasket	Graphite+304	Graphite+304
8	Stud	A193-B7	A193-B7
9	Nut	A194-2H	A194-2H
10	Bonnet	A216-WCB	A216-WCB
11	Back seat	A276-410	A276-304
12	Packing	Graphite	Graphite
13	Packing press-sleeve	A276-420	A276-420
14	Packing gland	A276-WCB	A216-WCB
15	Yoke	A216-WCB	A216-WCB
16	Stem nut	C95500	C95500
17	Gland	A105	A105
18	Hand wheel	A536-60-40-18	A536-60-40-18
19	Indicating cover	A105	A105

Notes: Materials can be designed and selected based on actual work condition or customers' specific requirement.

## EXPANDING GATE VALVE

- Cast Steel Slab Gate Valve, Double Expanding
- Outside Screw and York, Rising Stem,
- Double Block and Bleed, Self-relieving
- Emergency Sealing Injection System
- Designed to API 6D

Face to Face	ASME/ANSI B16.10
End Flange	ASME/ANSI B16.5
Butt Weld	ASME/ANSI B16.25
Class	ASME/ANSI CL150/300

## CLASS 150 DIMENSIONS

SIZE (in.)	FLG		B.W		H	H2	D0	B	B1	B0	G.O SIZE	Unit:mm
	L	L1	L1	L1								
2	250	216	475	360	250	-	-	-	-	-	-	-
2-1/2	280	241	535	425	300	-	-	-	-	-	-	-
3	310	283	600	460	300	-	-	-	-	-	-	-
4	350	305	700	535	350	-	-	-	-	-	-	-
6	450	403	910	685	350	-	-	-	-	-	-	-
8	550	419	1095	815	350	1235	900	310	BA-0	-	-	-
10	650	457	1370	965	450	1510	1050	310	BA-0	-	-	-
12	750	502	1470	1100	500	1610	1185	310	BA-0	-	-	-
14	850	572	1730	1250	600	1890	1345	460	BA-1	-	-	-
16	950	610	1870	1375	650	2030	1470	460	BA-1	-	-	-
18	1050	660	2185	1485	700	2415	1625	460	BA-2	-	-	-
20	1150	711	2335	1575	800	2565	1715	460	BA-2	-	-	-
24	1350	813	2815	1995	1000	3045	2135	460	BA-2	-	-	-
28	1450	914	-	-	-	-	-	-	-	-	-	-
32	1650	965	-	-	-	-	-	-	-	-	-	-
36	1880	1016	-	-	-	-	-	-	-	-	-	-

## CLASS 300 DIMENSIONS

SIZE (in.)	FLG		B.W		H	H2	D0	B	B1	B0	G.O SIZE	Unit:mm
	L	L1	L1	L1								
2	216	216	475	360	250	-	-	-	-	-	-	-
2-1/2	241	241	535	425	300	-	-	-	-	-	-	-
3	283	283	600	460	300	-	-	-	-	-	-	-
4	305	305	700	535	350	-	-	-	-	-	-	-
6	403	403	910	685	350	-	-	-	-	-	-	-
8	419	419	1095	815	350	1235	900	310	BA-0	-	-	-
10	457	457	1370	965	450	1510	1050	310	BA-0	-	-	-
12	502	502	1470	1100	500	1610	1185	310	BA-0	-	-	-
14	762	762	1730	1250	600	1890	1345	460	BA-1	-	-	-
16	838	838	1870	1375	650	2030	1470	460	BA-1	-	-	-
18	914	914	2185	1485	700	2415	1625	460	BA-2	-	-	-
20	991	991	2335	1575	800	2565	1715	460	BA-2	-	-	-
24	1143	1143	2815	1995	1000	3045	2135	460	BA-2	-	-	-
28	1346	1346	-	-	-	-	-	-	-	-	-	-
32	1524	1524	-	-	-	-	-	-	-	-	-	-
36	1727	1727	-	-	-	-	-	-	-	-	-	-

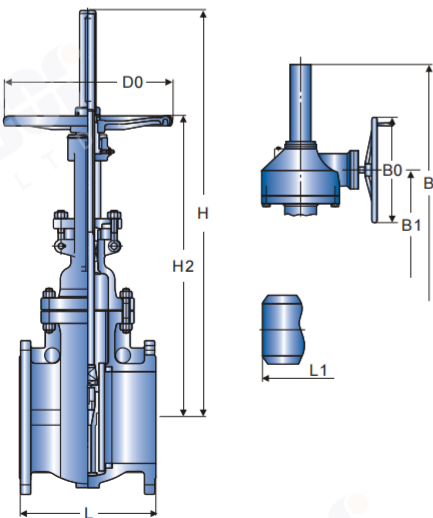

# Slab Gate Valve, Gate, Globe, Check Valve

## EXPANDING GATE VALVE

- Cast Steel Slab Gate Valve, Double Expanding
- Outside Screw and York, Rising Stem,
- Double Block and Bleed, Self-relieving
- Emergency Sealing Injection System
- Designed to API 6D

Face to Face	ASME/ANSI B16.10
End Flange	ASME/ANSI B16.5
Butt Weld	ASME/ANSI B16.25
Class	ASME/ANSI CL400

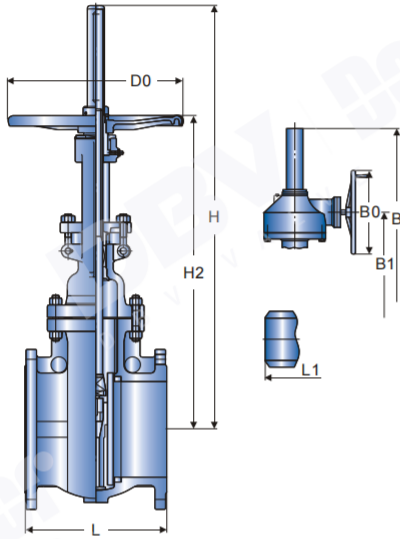

## CLASS 400 DIMENSIONS

SIZE (in.)	FLG L	B.W L1	H	H2	D0	B	B1	B0	G.O SIZE
Unit:mm									
2	292	292	499	378	250	-	-	-	-
2-1/2	330	330	562	446	300	-	-	-	-
3	356	356	630	483	300	-	-	-	-
4	406	406	735	562	350	-	-	-	-
6	495	495	956	720	350	1096	805	305	BA-0
8	597	597	1150	856	400	1290	941	305	BA-0
10	673	673	1439	1013	500	1580	1098	305	BA-0
12	762	762	1545	1155	600	1705	1250	458	BA-1
14	826	826	1817	1313	650	1977	1408	458	BA-1
16	902	902	1965	1445	700	2125	1540	458	BA-1
18	978	978	2295	1560	800	2525	1700	458	BA-2
20	1054	1054	2452	1655	1000	2682	1795	458	BA-2
24	1232	1232	-	-	-	3186	2235	458	BA-2
28	1397	1397	-	-	-	-	-	-	-
32	1650	1650	-	-	-	-	-	-	-
36	1880	1880	-	-	-	-	-	-	-

## OIL FIELD SLAB GATE VALVE

- Cast Steel Slab Gate Valve
- Outside Screw and York, Rising Stem,
- Double Block and Bleed, Self-relieving
- Emergency Sealing Injection System
- Designed to API 6D

Face to Face	ASME/ANSI B16.10
End Flange	ASME/ANSI B16.5
Butt Weld	ASME/ANSI B16.25
Class	ASME/ANSI CL150

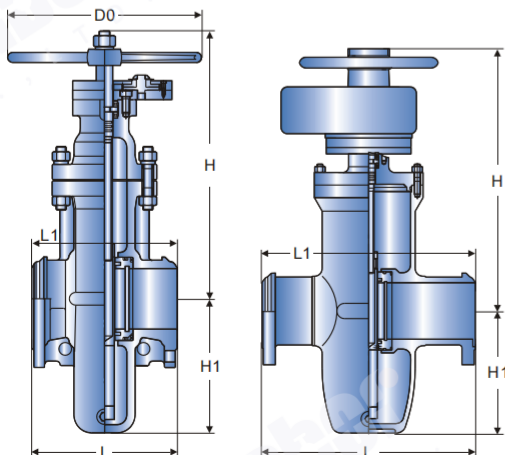

## CLASS 150 DIMENSIONS

SIZE (in.)	FLG L	B.W L1	H1	H	D0	H1	H	D0	G.O SIZE
Unit:mm									
1	165	-	85	228	180	-	-	-	-
1-1/4	165	-	103	231	180	-	-	-	-
1-1/2	178	-	115	240	250	-	-	-	-
2	178	216	130	255	250	-	-	-	-
2-1/2	190	241	160	355	300	-	-	-	-
3	203	283	180	360	300	-	-	-	-
4	229	305	214	400	300	-	-	-	-
5	254	381	257	460	350	-	-	-	-
6	267	403	300	500	350	-	-	-	-
8	292	419	388	570	350	-	-	-	-
10	330	457	475	680	400	475	700	350	0
12	356	502	547	750	450	547	870	350	0
14	381	572	625	875	450	625	995	450	1
16	406	610	712	1000	500	712	1120	450	1
18	432	660	785	1130	500	785	1280	450	1
20	457	711	880	1200	600	880	1350	450	1
24	508	813	1045	1420	800	1045	1570	500	2
28	610	914	1190	1650	800	1190	1800	500	2
32	660	914	1360	1880	1000	1360	2040	500	2
36	771	1016	1510	2100	1000	1510	2280	600	3
40	811	-	1715	2300	1200	1715	2480	600	3

# Slab Gate Valve

## OIL FIELD SLAB GATE VALVE

- Cast Steel Slab Gate Valve
- Outside Screw and York, Rising Stem,
- Double Block and Bleed, Self-relieving
- Emergence Sealing Injection System
- Designed to API 6D

Face to Face	ASME/ANSI B16.10
End Flange	ASME/ANSI B16.5
Butt Weld	ASME/ANSI B16.25
Class	ASME/ANSI CL300

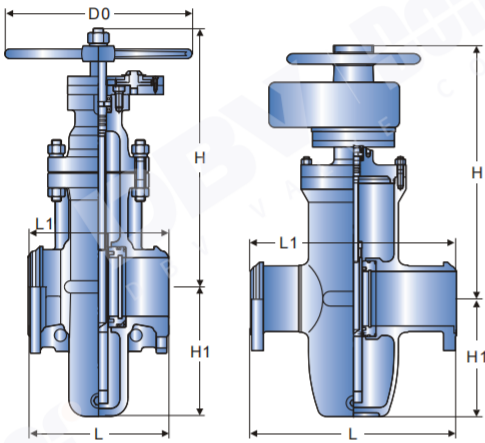

## CLASS 300 DIMENSIONS

SIZE (in.)	FLG L	B.W L1	H1	H	D0	H1	H	D0	G.O SIZE
1	165	165	85	238	180	-	-	-	Unit:mm
1-1/4	178	178	103	238	180	-	-	-	-
1-1/2	190	190	115	245	250	-	-	-	-
2	216	216	130	265	250	-	-	-	-
2-1/2	241	241	160	365	300	-	-	-	-
3	283	283	180	375	300	-	-	-	-
4	305	305	214	420	300	-	-	-	-
5	381	381	257	480	350	-	-	-	-
6	403	403	300	520	350	-	-	-	-
8	419	419	388	590	350	388	710	350	0
10	457	457	475	700	400	475	820	350	0
12	502	502	547	780	450	547	900	450	1
14	762	762	625	895	450	625	1015	450	1
16	838	838	712	1020	550	712	1150	450	1
18	914	914	785	1150	700	785	1300	500	2
20	991	991	880	1220	800	880	1370	500	2
24	1143	1143	1045	1440	1000	1045	1620	600	3

## OIL FIELD SLAB GATE VALVE

- Cast Steel Slab Gate Valve
- Outside Screw and York, Rising Stem,
- Double Block and Bleed, Self-relieving
- Emergence Sealing Injection System
- Designed to API 6D

Face to Face	ASME/ANSI B16.10
End Flange	ASME/ANSI B16.5
Butt Weld	ASME/ANSI B16.25
Class	ASME/ANSI CL400

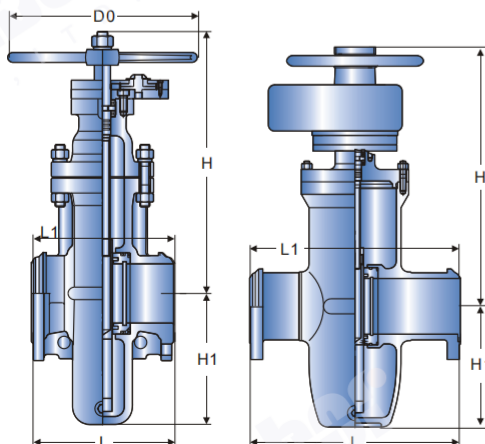

## CLASS 400 DIMENSIONS

SIZE (in.)	FLG L	B.W L1	H1	H	D0	H1	H	D0	G.O SIZE
2	216	250	158	265	300	-	-	-	Unit:mm
2-1/2	241	280	190	365	300	-	-	-	-
3	283	310	225	375	350	-	-	-	-
4	305	350	255	420	350	-	-	-	-
5	381	400	275	480	400	-	-	-	-
6	403	450	330	520	400	-	-	-	-
8	419	550	410	590	500	388	710	350	0
10	457	650	490	700	500	475	820	350	0
12	502	750	570	780	600	547	900	450	1
14	762	850	625	910	600	625	1015	450	1
16	838	950	735	1020	700	712	1150	450	1



E-mail: [info@dbv-armaturen.com](mailto:info@dbv-armaturen.com)

[www.dbvvalve.com](http://www.dbvvalve.com)

[www.dombor.com](http://www.dombor.com)

Tel: +86-577-67387723

Fax: +86-577-67383000

Add: No.96 Fanhua East Road, OuBei, WenZhou, Zhejiang, China



DBV Web



Dombor Web



linkedin



instagram



youtube



facebook

This manual is printed on eco-paper!

Due to the continuous innovation of technology and process of "DBV" products, this information is for reference only. Our company reserves the right of final interpretation.

"DBV" and "dombor" are registered trademarks of "DBV Valve Co.,Ltd" All rights reserved. Copies must be investigated!